

**THE PSYCHOLOGY OF THE
USE OF AUDIO-VISUAL AIDS
IN PRIMARY EDUCATION.**

by G. Mialaret

GEORGE G. HARRAP & CO. LTD
London Toronto Wellington Sydney
AND
**UNITED NATIONS EDUCATIONAL, SCIENTIFIC
AND CULTURAL ORGANIZATION**
Paris

MONOGRAPHS ON EDUCATION—V

Previous titles in this series published by Unesco :

- I. *Adult education in Yugoslavia*, by M. David
- II. *The primary school curriculum*, by Robert Dottrens
- III. *Polytechnical education in the U.S.S.R.*, edited by S. G. Shapovalenko
- IV. *New trends in adult education: from Elsinore to Montreal*, by A. S. M. Hely

*First published in Great Britain 1966
by George G. Harrap & Co. Ltd
182 High Holborn, London, W.C.1 and
the United Nations Educational, Scientific
and Cultural Organization
Place de Fontenoy, Paris-7^e, France*

*Composed in Linotype Times and printed by
Western Printing Services Ltd, Bristol
Made in Great Britain*



© Unesco 1966
Copyright. All rights reserved
(A.2041)

PREFACE

Since 1953 Unesco has been promoting the study, use, and production of educational aids in its Member States. A simple enumeration of the international meetings devoted to audio-visual aids in education indicates how constant this effort has been: Messina (1953), New Delhi (1958), Mexico (1959), Tokyo (1960), Kuala Lumpur (1961), Moshi (1961). The meeting of experts on "New methods and techniques in education" (Paris, March 1962) and the seminar at Caen (May 1962), with which we are here concerned, are both part of this effort. In the latter case, however, emphasis was placed upon effecting improvement in the methods and means of teaching, or, to put it another way, upon developing a more scientific use of teaching aids. Each of these meetings, seminars, study groups, and workshops has given rise to Reports which can be obtained directly from Unesco. The psychology of the use of audio-visual aids, on the other hand, necessitated a larger framework, both because of the difficult nature of the subject itself and because of the scientific method required. Hence we are devoting this volume to it.

In his Introduction, Professor Mialaret, Director of the *Laboratoire de Psychopédagogie* in the University of Caen, explains the origin of the work, describes its framework and limits, and recalls the objectives of the seminar. The work, which is intended primarily for teachers of psychology and education in teacher-training centres and for research workers, should find a place in the libraries of teacher-training institutions, in educational documentation centres, in their audio-visual services, and in the libraries of educational establishments in general.

The author has endeavoured to express in a non-technical language both his own ideas and the results of somewhat complicated studies. Certain technical terms have been unavoidable, but a well-used technical term rarely causes confusion, and this volume

6 Preface

is not designed simply as a handbook for educational psychologists; it is hoped that it will also serve as a guide for educators who wish to use audio-visual aids intelligently.

Finally, it should be noted that the views contained in the study are not necessarily those of Unesco.

CONTENTS

Preface	5
Introduction	9
Chapter I. <i>Some thoughts on scientific research</i>	14
Chapter II. <i>Basic phenomena of perception</i>	23
General	23
Some direct applications to audio-visual situations	31
Visual perception	64
Auditory perception	98
Audio-visual association	113
Chapter III. <i>Further psychological aspects</i>	126
Empathy phenomena and the behaviour of the child spectator	126
Comprehension	159
Creation of motivation	186
Chapter IV. <i>Conclusions</i>	191
Bibliography	212

INTRODUCTION

This report is an attempt to study the scientific aspects of the educational psychology of some audio-visual aids used in education. In order that it may be as constructive as possible, the meaning of certain expressions must be clarified and the subject of study placed in the larger framework of how this book came to be written.

We have not hesitated to stress the expression 'educational psychology' despite a seeming contradiction in terms caused by the fact that psychology is associated with science and education with the art of teaching. Studies in educational psychology cover a field which is quite clearly defined as the behaviour of an individual in the educational situation, 'behaviour' being taken here in the wide sense as the totality of physiological, psychological, and social reactions and interactions integrated by the personality.¹

The use of new audio-visual techniques in schools has created a new educational situation which gives rise to new types of behaviour on the part of teachers as well as pupils. The present report is an examination of some of these new types of behaviour, and is best placed in the context of the use of audio-visual aids in primary school. New educational techniques, whether audio-visual or not, are usually discovered and introduced in a somewhat haphazard manner. The technique is tried out before its full potential is understood, though it may be suspect (see p. 17 below for precautions to be observed). After this first trial, the use of the new instrument is gradually improved. Taking into account observations made by teachers in their classroom work (often more or less preconceived notions), technical and educational suggestions made by inventors, and straightforward possibilities revealed through use, there comes a

¹ We propose to adopt these definitions provisionally without further discussion of the meaning of each term.

10 *Introduction*

point, after much trial and error, where it becomes possible to define the main lines to be followed in using the instrument for practical educational purposes. It might be added that the length of this first period depends upon the amount of research that has been done and on the development of the science in general, because the various fields of human activity are all interrelated, and it is virtually impossible to speak of one in complete isolation from the others. We can say, for example, that it required a much longer time for the book to be pressed into service as an educational instrument than for the cinema to be so used, and that in turn it took longer for the latter to come into use than it has taken for television. Although each new technique has its element of originality, it benefits from the methods of study and experiment used with those that preceded it.

Once the ground has been broken, another form of scientific research can be undertaken. It is not possible, for example, to study certain processes of perception or comprehension of an image on a screen if it does not come up to a certain standard of quality or if an educational film is shown to children at the wrong time. Before any experimental work can be done to analyse the various psychological reactions of children and study their comprehension difficulties, the necessary educational conditions must be carefully, though not rigidly, organized. If we consider psychological reactions to be largely conditioned by the situation in which they arise, we will attach great importance to the teaching situation, and we must strive to understand it thoroughly in order to interpret experimental data correctly. Hence it is necessary for an educational psychologist to be trained in both education and psychology, so that he can make an accurate analysis of the educational and psychological elements of the experiment. In our opinion, to isolate psychology from the educational situation is contrary to the general trend in the sciences concerned with man.

Research undertaken along the two lines which we have just mentioned is usually complementary. Either it is assumed that the educational situation is constant, thus permitting the psychological phenomena arising from it to be studied, or else an attempt is made to vary the component elements of the educational situation in order to discover new uses for a particular technique or to devise instruments which will improve its effectiveness. Whichever approach is taken, the educational situation is unchanged at this stage, but our understanding of it has become more explicit, more analytical, and more sure. This deepening of our understanding makes our teaching

action more effective and reduces the danger of using a given technique too unscientifically. Once again we realize how necessary it is to consider these problems both from an educational and psychological point of view, as defined above.

Research work of this nature should be undertaken in a spirit that is as scientific as possible, and we shall now define briefly what this attitude, to which we attribute primary importance, should be. As we have already attempted to show, there should be no opposition between practical teaching and scientific research in education. The art of teaching has nothing to fear from science; on the contrary, it has everything to gain in the way of improved instruments and better conditions.

The essential characteristic of the scientific approach is a desire to make tests using standards which have been sufficiently well worked out and established after long and often laborious analytical work. Hypotheses are suggested from direct observation, from the result of previous experiments, through the intuition of the person carrying out the research, or arise from the general situation. The scientific approach requires that these hypotheses then be subjected to as strict a verification as possible (*cf.* the necessary precautions referred to below), after establishing a precise experimental plan to be used in this verification, together with the technical methods, the qualitative and quantitative procedures of analysis, and the range within which an interpretation may be considered valid. Obviously perfection of this type towards which scientific research aspires is not always reached, and, depending upon the aim of the research and on the educational situation, we are apt to find any level of accuracy running from simple observation to rigorous scientific experimentation, where every factor is accounted for and measured. In such work, every technique known to scientific research should be utilized, including observation, measurement, questionnaires, projection tests, and various other types of data collection and analysis.

An examination of all the problems raised by the mass use of audio-visual techniques would require a work which would take us far beyond the limits of the present study. We have therefore somewhat arbitrarily set up a double limitation which we shall now explain briefly.

In this study, we have partly neglected radio and television, which pose a series of specific problems requiring separate treatment.

12 *Introduction*

This does not mean that these branches will not be taken into consideration whenever the occasion arises. Conversely, results obtained from the study of visual or auditory perception can be applied directly to radio and television. It has not been our intention, however, to cover all the problems linked with the reception of a series of outside broadcasts, the form in which they are presented and their duration, or the sociological phenomena involved. In point of fact, we have been concerned only with those audio-visual techniques which the educator may constantly have at his disposal in a classroom, or those devised or built by the teacher for his own purposes as a teacher. Obviously these limits are not as clearly defined as they might be, and many of our conclusions will prove valid for the whole field of audio-visual techniques.

Moreover, in order to reduce our psychological considerations and not become involved in too many aspects of this science, another limitation has been imposed. This concerns the age of the subjects being tested. We have eliminated the study of the psychological problems of very young children (under seven years of age), as well as those which make their appearance at the time of adolescence (12-13 years). Obviously such a division is artificial from a psychological point of view, but it keeps discussion from straying off into every possible aspect of psychology. We shall be obliged to refer to areas that we have eliminated, however, because it is impossible to have an exact understanding of certain psychological processes unless we understand them in their earlier and later phases.

The present work is the result of lengthy studies in which the seminar held at the University of Caen from May 3rd to 12th, 1962, was one of the highlights. Without underestimating the rôle of the rapporteur, it is only fair to say that all the participants, in a spirit of goodwill and enthusiasm which merits recognition, have had a share in gathering the documentation, filling out the bibliography, and discussing the experiments and ideas under consideration. Certain portions of this work will reproduce almost verbatim all or part of the papers read or the oral contributions made. We shall give due credit wherever we can, but it is impossible to attribute every intelligent remark or every basic idea to the person responsible for it. Hence we propose to list the names of those who took part in the seminar. They are the co-authors of this work, and I wish to express to them my personal feelings of friendship and my gratitude for the assistance they have given me. They are:

- G. E. R. Burroughs, Senior Lecturer in Education, University of Birmingham.
- G. Cohen-Seat, Director, Institute of Filmology, University of Paris.
- J. Gaudreau, Director, Laboratory of Experimental Psychology, University of Montreal.
- H. de Jong, Division of Diffusion Techniques, Department of Mass Communication, Unesco.
- W. Lanz, Assistant Principal, Cantonal Gymnasium of La Chaux-de-Fonds, Neuchâtel.
- Mme L. Leboutet, Assistant Professor of Psychology, University of Caen.
- R. Lefranc, Director, Audio Visual Centre of Saint-Cloud, Saint-Cloud.
- Mme A. Leroy-Boussion, Research Director, CNRS, Faculty of Science, University of Aix-Marseille.
- A. Lestage, Chief, Division of Curricula and Methods, Department of Education, Unesco.
- C. Malandain, Research Director, CREDIF, Saint-Cloud.
- E. Malmquist, Professor of Education, University of Linköping.
- W. C. Meierhenry, Assistant Professor of Education (Visual-Aids), Department of Education, University of Nebraska.
- Professor Dr Emilio Mira y López.¹
- H. Philp, Director, International Institute of Child Study, Bangkok.
- M. Roothoof, producer and director of educational films (Belgium).
- Signora E. Tarroni, Assistant Professor of the Psychology of Communications, Department of Education, University of Rome.

¹ Since deceased.

CHAPTER 1

SOME THOUGHTS ON SCIENTIFIC RESEARCH

We do not intend, in this short chapter, to consider all the problems of scientific research in the social sciences; after summarizing the various forms which the activities of the research worker take, we shall merely point out and enumerate the main difficulties. The object of these few pages is to make the reader aware of the extraordinary complexity of the situations which we are about to examine, and induce the necessary caution in accepting or rejecting the ideas presented later.

In the teaching situations we are examining here, the research methods used will be the same as in all the psycho-social and teaching sciences. Observation is present at all its levels and in all its forms: the observation of a child as he looks at a film, for example, observation in a highly schematic situation, simple observation, and observation aided by all the current technical devices for registering events. Here we might refer to the excellent example of the observations made by Zazzo and his team of collaborators during the international competition of films for children (232), or the example of Mme A. Leroy-Boussion about which we shall speak later (133 *et seq.*).¹

Observation is often supplemented by an interview with the subjects of the test, with a view to making a fuller analysis of their reactions and behaviour. Thus, after showing a film, G. Mialaret and M. G. Méliès questioned some of the children and provided some material to help them in reconstituting the scene in which the action of the film took place. From this point onward research becomes rather a clinical interview, the bases for which were extraordinarily well established by J. Piaget (172).

Whenever possible, this long and meticulous form of research is supplemented by some form of inquiry designed to assemble a large

¹ The numbers in brackets refer to the bibliography at the end of this book.

amount of data more rapidly. For example, after projecting a film about the area of a parallelogram, Mialaret gave the pupils a questionnaire; their replies to it indicated what they had or had not understood in the film.

A comparison of the results obtained by similar groups of subjects opens up the way to experiment in which one varies one or more factors in a given situation. The number of types of experiment in an audio-visual teaching situation is very large, since different factors can be tried successively, and the elements of the experiment can be varied to an infinite degree. As we shall see later, the variation can come from three main sources—the audio-visual document, the way in which it is utilized, and the actual subjects.

In the first case, the document is changed and the consequences of the change studied—*e.g.*, Cohen-Seat obtained new formulations of the different interpretations of spectators by prolonging by a few frames the look exchanged between two of the characters.

The moment chosen for introducing an audio-visual document during an apprenticeship gives rise to a whole series of experiments of the second type. In teaching foreign languages with the help of a tape-recorder, should it be used before, during, or after class teaching? When is it most effectively used?

The third type of experiment is obtained by taking subjects falling into different categories. Professor Heuyer gives the following example:

Using material supplied to us by a child psychiatry clinic, we studied the reactions of maladjusted children—*i.e.*, children or adolescents in whom emotional disturbance led to troubles of behaviour or conduct in the family, school, apprenticeship centre, and, in general, in the social groups the children frequented. In given situations, and as compared with those of normal subjects, clear and often heightened reactions can be obtained from an audience of maladjusted children. They differ from mental patients in being able to follow a show and find something of interest in it. But because of their emotional disturbance they are spectators whose lively reactions are easier to grasp than those of subjects who are balanced and observe social restraints. (106)

Research techniques are thus as varied in the psychology of the use of audio-visual aids as anywhere else. The research worker does not hesitate to go from the individual to the group, from the normal subject to the abnormal, taking in the maladjusted on the way, from

16 *Some Thoughts on Scientific Research*

the most simple observation to experiment involving the most elaborate scientific techniques.

Although it is easy to describe this research in broad outline, in practice there are certain difficulties which we must not fail to mention. If only what is measurable is scientific, the limits of scientific research in audio-visual matters would be very narrow. It is easy to think up experiments, but what are we going to measure? It is often difficult to evaluate the effect of a record or of a film on a subject, and it is not easy to see how the research worker is going to measure the effect. The emotional or intellectual impact can be considerable, and a film may have decisive consequences on the conduct and on the subsequent behaviour pattern of a subject without it being in any way easy to submit these consequences to an elaborate scientific analysis. In the various matters explored we must not expect to find the mathematical wealth which scientific research provides elsewhere; here again we encounter the difficulties which have hindered the development of certain aspects of experimental education.

What effects are we interested in? We know that the act of teaching has short- and long-term consequences, and that audio-visual techniques are simply one aspect of it. The introduction of sound illustrations in history lessons has repercussions which occur at very different levels; at what moment should the effect of these sound illustrations be studied, and possibly measured—immediately after the experiment, the following day, several days later, or even still later? Will certain effects which at first glance seem positive or negative still appear positive or negative a little while later? It would be very easy to find examples of results which seem excellent at a given moment but whose ineffectiveness we can only deplore later; on the other hand, the seed which is sown gives its fruits only afterwards, and the fertility of certain acquisitions which appear insignificant at the beginning may not appear to be considerable until months later. In certain cases, it might well seem that the investigation should be made precisely when the psychological processes begin to take shape—*i.e.*, during the actual audio-visual teaching situation. Several research workers have successfully observed one or more subjects during a film projection, even recording their reactions at the actual time of occurrence. Thanks to a very simple recording arrangement, it has been possible to observe the emotional reactions of certain subjects quite precisely, to record

variations in their psycho-galvanic activity and even in their electroencephalographs during the projection of certain films (108); infra-red photography at predetermined times has made it possible to analyse accurately the expressions on children's faces and to embark upon the study of a large number of physiological, psychological, and social effects.

It is at the moment difficult to separate the direct from the indirect effects in the new teaching situation created by using audio-visual techniques. In certain cases, it is the direct acquisitions which are the most important (the effect of a film about geography, for example), and the checks are easy to make. In other cases, however, audio-visual techniques play the rôle of a catalyst; they prepare the way for acquiring something else, help to develop an aptitude which will be used later in an apprenticeship, and prepare favourable ground for a new acquisition. It is always difficult to make a fair estimate of the motivation thus introduced into the educational process.

Similarly, going back to the distinctions of classical psychology, it is evident that in certain cases the effectiveness of audio-visual techniques can be appreciated in terms of intelligence, logic, and 'clear and distinct' acquisitions; in many other cases, however, it is the affective zones, the emotions and feelings, which have been touched and transformed. Moreover, we know perfectly well that it is in fact the whole personality of the subject which has been subjected to the effect the educator wanted, and even if this effect is more clearly visible in one respect than in another, it nevertheless sensitizes other areas of the psyche.

In actually evaluating the results, the problem can be put otherwise by making a distinction between conscious and unconscious effects. When a questionnaire is used after a film, part of the conscious effects of the film are studied, since the subject relates the question asked of him clearly to the content of the documents he has been given, and the effects are then easy to determine. All the action which takes place at a level below the level of consciousness remains, however, and its effect on subsequent conduct will be no less. We know now that our actions are not determined only by clear and rational motives and that our behaviour is the result of many influences amongst which the unconscious variables are not the least.

It must be added that, too often also, it is considered enough to study the individual effects of teaching techniques. These effects are

18 *Some Thoughts on Scientific Research*

the easiest to observe and measure, but we should not neglect the social effects seen as interpersonal effects or group effects. It should be mentioned here that methods of evaluating such effects have not been greatly used and consequently are not highly developed.

We have referred to the difficulties met with assuming that every use of audio-visual techniques was pedagogically valid without raising the question whether it was legitimate to make this assumption. Scientific research sometimes comes up against a barrier which we must consider as unsurmountable. In teaching—and we must regard audio-visual techniques simply as an aspect of teaching—every experiment represents an action, and we have no right to act if our action presents the slightest danger to the subjects affected by it. The research worker is also limited in what he can do by his rôle of educator, and no research should be undertaken unless it has the approval of the teacher. Children are not guinea-pigs, and we are not entitled to disturb them profoundly—and for long periods—possibly to the point of inducing traumatism.

This is one of the special difficulties of educational research, and the effectiveness of certain audio-visual techniques is all the more reason to stress it. Thus the research worker should sometimes stop his scientific inquiry, and content himself with unsystematically collected data in verifying certain hypotheses where a more complicated check would involve procedures injurious to those co-operating with him.

It is not enough to obtain qualitative and quantitative results. The aim of scientific research is not to obtain figures for their own sake. The main point is the interpretation of the results with a view to either confirming or rejecting the hypotheses submitted for verification. In certain situations, it is possible to use concepts already elaborated in psychology, sociology, and education and apply them to the new teaching situation brought about by the use of audio-visual techniques. A kind of pre-prepared grid is applied, and the educational, psychological, and social processes are then studied through this conceptual apparatus. This has its advantages, but it also involves certain risks. The concepts used to understand and explain these situations (and their consequences) are filtered through philosophical criticism, and known as a result of the use to which they have already been put; they thus give to the research worker a feeling of security, and to the educated person the impression that

he understands and is able to keep up with scientific development. But thereby we run the danger of allowing new, original, and specific effects, not revealed when the conventional, conceptual framework is used, to escape unnoticed. That is why, in certain circumstances, the research worker is led to put forward new ideas and use new concepts with a view to interpreting more correctly and more completely the experimental results obtained. This gives rise to a new language which sometimes seems rather esoteric to the layman. It must be emphasized, however, that there is no question here of a childish desire simply to play about with words or with new ideas; the point at issue is a real, scientific need. The use of audio-visual techniques transforms classic teaching situations and gives rise to new effects which it is sometimes impossible to describe, analyse, or explain in current scientific language; where the effects are so new and specific we should not be surprised to find new ideas being used to explain the results obtained.

We are led, consequently, to acknowledge the existence of a subtle dialectic in which certain old ideas take on new life, become richer in understanding and scope, but in which it is impossible to avoid the introduction of new ideas in obtaining a coherent interpretation of the phenomena. The interpretation should thus call upon all aspects of human behaviour and take advantage of all the achievements of modern science. Because at one time there were those who, adhering to an outmoded system, tried mistakenly to find a single explanation for psychological phenomena on physical-physiological grounds, modern scientists, under the influence of Pavlov and his school, do not thereby hesitate to devote very considerable attention to the physiological components of behaviour. An attempt at such interpretation by L. V. Zankov will be found below in the working document supplied to participants at the symposium (224). Elsewhere, historical, geographical, sociological components may take precedence and be central to the interpretation. The surrounding geographical, economic, and political conditions affect all educational situations which are certainly not unaffected by the social context in which they occur. The research worker must take all these factors into account when he comes to interpret his results. The child living in an environment in which the visual image is a commonplace, where the cinema is part of the familiar, everyday world of all, or where the television screen is seen in numerous households, is in a completely different situation from a child to whom a cinema show is an exceptional event with a much greater

20 *Some Thoughts on Scientific Research*

impact than the other daily happenings.¹ The standard of living must also be taken into consideration because the difference between what the spectator knows and what is presented to him creates problems. In general, present-day scientific study of the educational and psychological aspects of using audio-visual aids cannot be completely carried out without taking into account results obtained under widely differing conditions. An interpretation which hopes to be comprehensive must be based on international documents, as only comparative studies will place in proper relief the original and specific features of each situation studied.

This kind of scientific study demands an education that is many-sided on the part of the research worker, and close collaboration between the different disciplines. If it is impossible to be a specialist in everything, we may say with P. Langevin that "culture is that which lays the individual open to the specialization of others". When the research is very advanced, the scientist can no longer be conceived of as a man of one discipline only. The age of narrow specialization (which was easy for the philosophers to caricature) is now outmoded. All that we have said above goes to show that, in the matters we are here concerned with, the research worker must be as competent in education, psychology, and physiology as he is in sociology and filmology, the latter taken in the widest sense of the word. Hence the necessity for teamwork if research is to be carried out in depth; collaboration between well-educated experts is vital to modern scientific activity. The recognition of the complexity of phenomena, the revelation of a determinism which is difficult to fit into a simple logical framework, the recognition of the extremely large—not to say infinite—number of variables that operate in apparently the most simple situation—all these mean that the present-day laboratory can no longer be the domain of a single man; it must be the meeting-place for all those whose disciplines contribute to the discovery of scientific truth.

We may complete what has been said above by emphasizing that, with audio-visual techniques as they are at present, no interpretation can be definitive. This is true for several reasons. In the first place, technology is developing very rapidly; for example, 'still' projection (either by projector or episcopes) is no longer what it was in 1940. Moreover, improvements in instruments and techniques for

¹ One of the experts at this symposium pointed out that 250,000,000 people in Asia had never seen a film or had the experience of a radio or television broadcast.

reproducing or preparing documents are transforming qualitatively the conditions under which our research is carried out; some difficulties disappear, other problems arise, and further research becomes necessary.

Again, the psychological conditions in which audio-visual situations and the subjects interact are constantly changing. Taking a spectator who is attending a filmshow for the first time, we can, by simplifying matters, imagine that his reaction—*i.e.*, the way he will feel and understand—will depend upon his psycho-biological equipment, which is in turn the result of hereditary influences, education, and the experiences and situations which have affected him. Attendance at a filmshow gives rise to two forms of activity at different levels and degrees of importance. We receive messages which become part of our existing personality, but these messages are not without their effects in turn on the very form of our own thought. This process may be slow and scarcely detectible in the adult, but it may be spectacular in young children and may explain why, very often, the adult has the impression of being left standing by someone who still seems to him a mere infant.

There are two different sets of problems, arising from the constant development of the research worker's own thought, and from the processes of adaptation of the subjects to technological developments. More than anywhere else, we must beware here of comparisons with what we knew twenty years ago, because practically every element of the two situations thus separated in time is different; and, as for the experimental variables, the research worker must always remember the factors which enable him to evaluate the level of audio-visual absorption his subject has already undergone.

The above observations on methods, difficulties, and some of the major problems of scientific research in the educational psychology of audio-visual techniques will help to make the reader familiar with some of the leading ideas which will serve as basic laws throughout this inquiry. They might be listed as follows:

1. Contact should be maintained between scientific research and its application in the teaching situation.
2. In view of the complexity of all educational situations, prudence should always be exercised when it comes to interpreting results and giving advice to users; what is valid and excellent for certain subjects can be disastrous for those in another environment.

22 *Some Thoughts on Scientific Research*

- 3. The problems involved in the educational and psychological aspects of audio-visual techniques are, by and large, so complex that very often research by teams is an essential prerequisite of success.**

CHAPTER 2

BASIC PHENOMENA OF PERCEPTION

I. GENERAL

Not all the problems of perception will be mentioned here, but fundamental data will be recalled, after which the data relevant to audio-visual research and its application will be examined so as to provide a basis for later discussion. After summarizing general views on the psychology of perception we will discuss their importance in situations in which audio-visual techniques are utilized, and then deal more particularly with visual perception, auditory perception, and the interactions between the two. In this last part, we shall introduce the results of psycho-physiological findings.

The problems of perception have been arbitrarily separated from problems relating to motivation and comprehension, which will be dealt with separately in Chapter 3. Demarcation between the two is difficult, and the reader is asked to pardon this separation, which is valid only as a rough approximation.

Three main elements of perception must always be considered and studied simultaneously—environment, the object of perception, and the subject which perceives. It will be necessary to examine the three aspects successively, but it must be made clear from the outset that there are various fundamental interactions between them. Environment is not an empty framework serving merely as a point of reference. It affects both object and subject, and the perceptible features of the first and the perceptive possibilities of the second often depend immediately upon it.

If perception is to be examined correctly, the term 'environment' must be taken in as wide a sense as possible, firstly because certain phenomena of transmission are dependent upon it from the 'geographical' or 'topographical' angle. In certain halls, the same sound stimulus is reproduced several times, whereas the ideal concert hall is one in which the sounds emitted by the instruments of the orchestra are transmitted to the entire audience with a minimum

24 *Basic Phenomena of Perception*

of distortion. In certain cases, points can be found where the sound intensity is non-existent despite the fairly large intensity of the sound stimulus. Accordingly, the perceptible message undergoes deformation from the outset, a weakening or reinforcement, and this means that the correlation between the basic physical characteristics of the stimulus and the psychological features of that which is perceived is never perfect. We shall revert to this important point, but it can be stated here that these properties are known and currently made use of in all radio sound effects—for example, to transform sound messages and give them the relief, colour, or richness which the situation demands.

This topographical aspect is, however, the simplest and is a mere introduction to other more complex and little-known problems. The environment is characterized not only by its extent and form but also by its physical and chemical structure, sometimes by its biological richness, and, in certain cases, by its history. When an object is seen by a subject, it can be said that the object sends back light received from the environment, and the form and colour perceived depend directly upon the physical characteristics of the environment in which the object is situated. A woman will not choose a length of cloth seen under just any light; she will insist on seeing it in daylight. The quality of advertisements or visual illusions is obtained by acting upon the environment in order to transform the perceptible features of objects; the same scene, lit successively by different coloured lighting, can represent an interior scene from the seventeenth, eighteenth, or twentieth century. The object itself is not changed, but the conditions of the environment have made certain parts appear or disappear and have given special aspects to others.

The same could be said about the relation of sound messages to the chemical composition of the elastic medium in which they are transmitted or the gaseous pressure whose effect on the speed of propagation cannot be neglected. This shows at the same time that the features of the environment which transform the message by creating certain special conditions of transmission operate on both object and subject. We shall see more of this in a moment.

The perception of an object by a subject is an extremely complex phenomenon, and we are far from sure whether a mental picture should be considered a copy, a reproduction, or an exact replica of the reality. The easiest way of getting at the problems which interest us would appear to be by investigating the way in which the

messages perceived are propagated. A sketch will eliminate the need for lengthy commentary and simplify the explanation.

The process of perception in time can be broken down by considering four or five different elements:

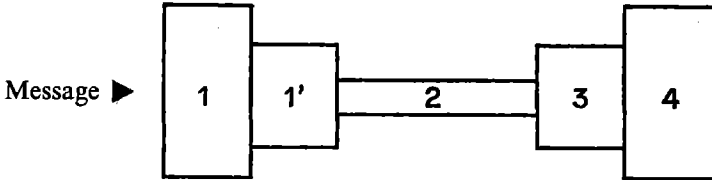

FIG. 1. THE PROCESS OF PERCEPTION

- | | |
|--------------------------------------|------------------------|
| 1. Extra-sensory perception. | 3. Cortical reception. |
| 1'. Action on the specific elements. | 4. Perception. |
| 2. Transmission of a nerve impulse. | |

Here again, of course, the breakdown can serve only for purposes of explanation, since the interaction of the different segments on one another and the relation of each with the personality as a whole are constant and constitute the fundamental psycho-physiological process.

Messages from the external world are captured by our sense organs. This is a simple statement, but it calls for considerable comment. It must be noted at once that we do not receive all the messages which are emitted by the external world, and we capture part only of the messages our sense organs can take. The number of stimuli produced or transmitted by the environment is very large, and human sense organs reveal to us only a very small part. Animals or objects such as a radio or television set, for example, can receive and utilize messages which are insensible to us. It can be said without hesitation that even where the sense activity does operate, the receiving band is relatively narrow and the receiving organ is not always very sensitive. A dog, for example, is sensitive to supersonics, and, after training, can be made to react to a whistle which is inaudible to man; a photographic plate is sensitive to ultra-violet rays which we do not perceive. With A. Carrel, we can imagine the idea we would have of the world if our sense organs had other qualities:

If, for example, the retina registered very long-wave infra-red rays, nature would appear to us quite different. Because of changes in temperature, the colour of water, rocks, and trees

26 *Basic Phenomena of Perception*

would vary with the seasons. Clear July days, when the slightest details of the countryside stand out against dark shadows, would be darkened by a reddish fog; the heat rays, having become visible, would search out every object. During the cold of winter, the atmosphere would become clearer and the contours of things more precise. Man's appearance would be greatly changed. His profile would be imprecise, a red cloud escaping from the nostrils and the mouth masking the face. After violent exercise the volume of the body would increase because the heat given off would surround it with a larger aura. The outside world, too, would change, although in a different way, if the retina became sensitive to ultra-violet rays, the skin to light rays, or simply if the sensitivity of each of our sense organs were to increase to a considerable degree. (42, p. 77)

The very form of the outer ear, the muscular anatomy of the eyeball, are such that the messages received are a small part only of what is transmitted from the environment. Taking the sense organs as being in what is considered good condition for ordinary mortals, it can easily be seen that any defects—or greater perfection—will modify the initial conditions of the process of perception.

A series of physico-physio-psychological phenomena must now be referred to. Speaking first of pre-perceptive reaction, a first reflex adaptation comes into operation as soon as a sense organ captures a message from outside; a beam of light falling on part of the retina will immediately provoke a modification of the position of the eyeballs so that the foveal region will be excited to the maximum. There is no need here to recall the partial reflex accommodation represented by contraction of the crystalline lens; by a series of automatic adjustments, equilibrium is established in such a way that the quantity of energy received is compatible with the structure and the functioning of the senses. It must not be believed that this automatic operation, under the influence of the major reflexes, represents only a minor mechanical aspect of our nervous activity; all modern works on physiology emphasize the unity of the nervous system, and it is now impossible to conceive the most elementary reflex as being completely independent of the personality as a whole. This will be worth remembering when these general ideas come to be applied to the audio-visual situation.

The message in its entry to and penetration of the sensory system undergoes modification before becoming what might properly be called an excitation. Refraction and distortion of the light beams take place in the eyes before these beams reach the retina. The most harmonious melody acts upon the eardrum, sets the chain of ossicles

in motion, and is transformed into a series of variations of pressure transmitted by the cochlea. A person's individual characteristics give these processes the mark of the whole personality, which is both the cause and the effect of these physiological aspects.

This first stage is prolonged by a second which, in the sketch above, is associated with the preceding one and is fundamental because it is the excitation proper. Specific sense cells transform the energy received into a nerve impulse which is sent towards the higher nervous centres. Here the processes vary with the sense organ, and there is not much point, so far as our purposes are concerned, in considering them further. Briefly, a chemical effect takes place at the retina, and retinal decomposition corresponds to the transformation of light energy into electric energy; in the Corti cells of the inner ear, a lengthening gives rise to a nerve impulse which is transmitted by the auditory nerve. Here it is possible to speak of sensory specificity because the transformation phenomena occur only in the presence of the corresponding form of energy which activates the specialized cells. We are thus far from the naïve belief that reality is transmitted in the form of images directly received by the brain; at this level, homogeneity between the object and the nerve impulse which sets out towards the upper centres no longer exists.

The second stage is transmission which mainly interests the physiologist but to which the psychologist is not wholly indifferent. In accordance with the general laws of neural physiology, the nerve impulses are transmitted, pass through a series of relays, and are guided by mechanisms which we are only just beginning to discover and understand. (See, in particular, the works of Dell (1952) and Magoun (1954) on reticular structure.) It would be easy, by going into details on this point, to find again all the complex relations of these phenomena of transmission with personality as a whole and with the general influence of the situation in which the perceiving subject finds himself. Here we need refer only to the importance of the thalamic relays which the work of Delay and his school have revealed. It is known that the diencephalic region can be considered as the affective brain of the organism, and that it is here that the distinction made by Head between protopathic sensitivity and epicritic sensitivity can be taken up. At the level of the thalamus, the affective constituents of the transmitted nervous message appear, while a last neuron brings to the cortex the nerve impulse which provokes the cortical phenomenon, the point of departure for perception proper.

Here reference must be made in the case of the third stage to the various investigations which, starting from the naïve theories of Gall regarding cerebral localizations and taking in Gestalt theories on the way, led to the modern concepts. In brief, it is known that the main nerve systems terminate in areas which are well delineated, and that the arrival of nerve impulses brings about clearly traceable electrical and chemical phenomena in areas where the nerve fibre in question flourishes. These nerve impulses can also be measured in other parts of the brain. Here again we find a form of equilibrium resulting from the innumerable series of nerve impulses which the cerebral hemispheres constantly receive. To prepare the way for later discussions, it may also be added that each object is not the originator of a single form of message and that the body as a whole simultaneously captures even in what is a very precise situation a complex of visual, auditive, olfactory, and tactile stimuli. Listening to an organ in a church, we receive visual messages, hear music, have our whole bodies physically shaken by powerful air vibrations (which in the case of particularly powerful organs can even lead to the collapse of the building), and can breathe in the characteristic odour of incense. Taking a slightly caricatured view of ourselves, we can then imagine the cerebral cortex as the scene of a complicated ballet of nerve impulses constantly criss-crossing and subtle chemical reactions functioning at neuron level—*i.e.*, the level of the infinitely small.

The perceptive state proper is arrived at through the interpretation of these physio-chemical messages. The variation of the cerebral potential gives rise to an original phenomenon the conditions of which are physiological, but the manifestations of which are matters of psychology. It is difficult to discuss in a few lines the foregoing statement which is supported by the work of Pavlov on the first and second systems of signals, but we shall try, in as simple a way as possible, to justify it.

How does a human being succeed in this extraordinary interpretation of nervous messages and arrive at the precise perception which he often, and with reason, takes pride in? In trying to answer that question we must not hesitate to investigate the genesis of the actual process. It is reasonable to assume that a baby's impressions are rather ill-defined, limited to what is felt to be agreeable or disagreeable. By a series of extraordinarily subtle conditionings, relations are formed between the different situations in which the child finds itself and the impressions it feels. By the operation of

generalization and differential inhibition, this conditioning applies to nuances ever more slight, and this process, which develops at the level of the first system of signals, becomes still more comprehensive at the time when language is acquired, and ends up, in the adult, as a sensitivity of extraordinary precision.

By regarding the question in this manner, it is possible to explain coherently a number of psychological facts which are important for this study. One of these concerns the impossibility of separating the perceptive phenomenon from the whole of the subject's personality—*i.e.*, what he is and what he has been. As was stated above, the interpretation given to nervous messages received is gained from the specific situations the subject has experienced, and the conditioning which then operates bears—sometimes for a long period—the imprint of the moment and of its effect on the subject. Hence, as all who use projective tests in a psychological clinic will know, subjects will react very differently to the same external data: two subjects will see somewhat different things in the same image, and the final interpretations given may even be contradictory. This is why, on the basis of stories thought up by subjects in the presence of images (those of TAT, for example), psychologists can succeed in analysing deep-rooted elements in the psyche of a subject. This will also explain, to take the example often quoted in manuals of psychology, why, looking at the same countryside, the poet, the farmer, the engineer, the tourist, see quite different aspects, what is important for one being insignificant for another. Similarly, the discussions following the showing of a film in a film club indicate that the same thing happens in regard to the comprehension of a film.

The relations between perception and personality can be considered in another perspective which also shows the unity of the phenomenon. We have distinguished several elements in the propagation of messages and constantly emphasized that, even in the case of reflex reactions, the process depended upon the working of the whole nervous system. Acquired habits are both physiological and psychological, and our whole body is involved in the way in which we have learned to receive and interpret messages. In other words, body constituents have entered into the process and play a rôle in reaching the final equilibrium. The rôle played by the tonic function in perception can be shown, for example, by the following experiment. A vertical luminous ray is projected before a subject sitting in darkness. To him it seems immobile. If methyl chloride is applied behind one of his ears,

30 *Basic Phenomena of Perception*

suddenly cooling the area and so acting unilaterally on the semi-circular channels (which are themselves in relation with the tonus centres), he will see the vertical line move parallel to itself although the actual distance between the subject and the object has not varied. This very simple experiment shows both the sensitivity of the psycho-physiological adjustments and the very different variables which come into play in the determination of the perceptive act.

This complexity does not deprive perception of the unity which results from an integration of all the messages recorded. It can be confidently said that there is no such thing as pure perception if we split up the perceptible world according to our different senses. Visual perception is always influenced by auditory, olfactory, and tactile impressions. The interpretation of visual data will vary according to the music which accompanies it, and hence be differently perceived. The separation of the visual from the auditory is the result of theoretical, verbal analysis, contrary to reality. A simple experiment will suffice to show the actual interactions. On a turning disc on which one or more spirals have been drawn it is possible, through a slit made in a piece of cardboard covering the whole arrangement, to give the impression that two particles move, approach each other, meet, and separate. Shown without comment to a group who were asked to say what they saw at the moment the two particles met, the experiment led to replies which were more or less evenly divided between two answers: balls which cross each other, and balls which meet and rebound. If either a whistle or a 'boom' is made when the particles are approaching each other, most of the subjects immediately see the balls cross with the whistle or rebound one upon the other when accompanied by the 'boom'. Visual perception was thus modified by the auditory message. This is very important in studying the effects of the film, for example, and, without anticipating later chapters, we can say it is well known that very different perceptions of the same thing can be obtained experimentally. If in several film sequences having different emotional overtones the same close-up of a face is introduced, this is seen by the same subjects, once as expressing sadness, another time as expressing joy, another as expressing an emotional state related to the situation in which the character is placed.

This same phenomenon could have been presented from the angle of a choice made by the subject, emphasizing that his perception of a situation reflected his personal preoccupations, that he was not

moved by certain important elements, and saw and understood only what his own personality extracted from the whole. This can be easily understood in the general framework given above, and it can also be easily understood how his previous habits, the situations he has known and experienced (above all, if they have been traumatic), seem to us to make an unconscious choice which is only the external aspect of the cortical interpretative process. The same applies, *mutatis mutandis*, to the social experience of the subjects, and we are not surprised when it is not the same elements of a picture or of a film which strike audiences situated in different parts of the world.

The aim of all that has been said above is to attempt to clarify and sharpen ideas about perception and to show that a scientific concept of it will take a large number of phenomena into account and give a coherent general interpretation of observations which sometimes are apparently contradictory. Not all of the problems of perception have been referred to, but the general framework given is large enough to take in the specific problems raised by audio-visual techniques.

II. SOME DIRECT APPLICATIONS TO AUDIO-VISUAL SITUATIONS

We do not propose to repeat one by one the items of the preceding section, but rather to consider a few specific problems which are part of the general situation brought about by the use of audio-visual techniques. For the sake of clarity we shall divide this section into three sub-headings:

- A. The situation.
- B. The audio-visual message.
- C. The individual.

A. THE SITUATION

Although it may seem somewhat paradoxical at first glance, one of the first characteristics of what we call the audio-visual situation is the disequilibrium and deformation of the structure of the audio-visual elements of the environment and the existence of the phenomenon of focusing. Let us clarify these points. The proper reception of a radio broadcast or the hearing of a recording, and the projection of slides or of a film, require special environmental conditions. In the first case, the intensity of any sound other than that

32 *Basic Phenomena of Perception*

coming from the loudspeaker must be reduced to the lowest possible level; the same is true in the second case of the intensity of light. In both cases there is present a phenomenon of focusing—that is, a particular concentration of the spectator's attention on the source of the messages. It should be noted that this focusing is of a different nature from that of voluntary attention in a normal situation. In the latter case the attention, as it were, originates with the individual and is directed towards the object (as it is, for example, with adults who go to the cinema by choice). In the audio-visual situation, the attention aroused is a response to the commanding nature of the message source; the force of this command will be proportional to the difference between the stimulus intensity of the message and that of the rest of the room, and attention is likely to be correspondingly intense. Two consequences of this should be noted: certain authors have not hesitated to compare this situation, in which attention is strongly focused, to a prehypnotic situation such as that induced by psychiatrists at the end of the last century; this has been used to explain in part the effect of the cinema on spectators. The same problem appears from another angle to have a second consequence: certain authors have spoken of the subject's being asleep to all that was not part of the message he was listening to or watching. Differences of intensity, either visual or auditory, foster this state of indifference to all that does not constitute the main field of perception, and it is frequently observed that an attentive spectator at the cinema pays no attention to his immediate neighbours, whereas this indifference is less often observed at the theatre (for which there are also other reasons which we shall not enter into here).

Here we again come upon the experimental results pointed out long ago by Pavlov and now being used in deep-sleep therapy. Pavlov had observed that when he eliminated experimentally all sources of external stimulation from a dog the animal fell asleep. Similar situations are produced in the present-day techniques of sleep psycho-therapy, with the addition of a weak periodic stimulus and the use of certain chemical substances.

A change in the balance of stimuli has another psychological effect which is important in the study of the psychology of audio-visual situations. The reduction in the intensity of messages received within a given sensory area increases the meaningfulness of the messages received in other sensory fields. This is easily explained by referring to the general outline of perception given above. A concert is heard

better in relative darkness than in a lighted concert hall; familiar noises which would go unnoticed during the day are perceived more clearly at night. Speaking more scientifically, it is well known that the elimination of visual messages alters the electro-encephalogram pattern in which alpha waves disappear and beta waves are strengthened when the retina is stimulated. The stronger impression of stimuli resulting from the general disequilibrium of messages received from the outside is the cause of many phenomena of panic in a dark hall; as soon as a serious incident has occurred in a cinema, the first thing to do is to turn on the lights in order to reduce the collective effects which may arise and lead to a real catastrophe. In the most childish plays, such as horror shows, darkness is always a terrifying element because of the feeling of insecurity which it produces.

Darkness, however, does not only produce effects which are apt to be dangerous; we must also consider its positive features. To refer again to what was said above, it may be pointed out first of all that to the extent to which it is conducive to a relatively intense attention, visual or auditory focusing is favourable to good perception and confers on the messages emitted a power of penetration which considerably increases their effectiveness. This explains in part the precision and number of memory impressions retained by young spectators who watch cinema programmes closely. It can even be observed sometimes that reception may be intense enough to produce a real identification of the spectators with the movement shown on the screen, and the individual has the impression of being in the car where the camera is, or in the wagon which is racing down the railroad tracks winding around the side of a mountain. Certain Cinerama films produce spectacular results, judging from the number of spectators who are made ill by them (*cf.* also Cinemascope films).

Darkness operates in another way by freeing the individual from certain social constraints which oblige him to play a rôle, thus permitting him to take a more active part in the situation. When episcopes and slide projectors were first used in developing countries it was very difficult, if not impossible, to arouse discussions in full daylight within a small group concerned with a given subject (agricultural methods, family or social problems, for example); each person remained silent because he realized that he was being observed by the others, and fear of making a mistake or of proving ridiculous produced a general silence. When the discussion grew

34 *Basic Phenomena of Perception*

out of the projected pictures tongues began to wag more readily, and many persons took part in the discussion in the dark; the individual no longer had the impression of being judged, observed, or recognized as he did in full daylight.¹

This result caused us to wonder how children reacted in the dark to a fixed or animated projection (152); other authors have compared the number of individual or social reactions during a film projection (232).

What we should like to stress here is the basic consequence of the situation of darkness which we have called the "liberation of individual mimicry" (152). In a lighted situation the child—or, for that matter, the adult—must consciously or unconsciously control the expression of his emotions. Without entering into the great psycho-philosophical discussions about the relationship between the emotions and their external manifestations (W. James, Sartre, etc.), we may simply say that it is certain that there are interactions between the internal and the external aspects of the process. The child to whom a story is being told must at one and the same time listen to it, feel an emotion which may be violent if it is a fairy-tale, for example, and control the external manifestations of his emotion (laughter and especially tears) for reasons of social discipline or personal dignity before his friends. We must not forget that, as the social psychologists remind us, we are constantly playing a rôle before other people and that the presence of other people deprives us in a large measure of our spontaneity. The situation is different when the same process takes place in darkness because the control of emotional display is reduced and the child may laugh, weep, or manifest his worry or fear more freely. We believe that the relative liberation of emotional expression affects the process itself and that the intensity of the emotion felt must be greater because the entire phenomenon has not been subject to this restraint. These few remarks would require lengthy discussion as well as serious experimental verification, but they show us that the conditions of perception (let us not forget that all messages perceived are relayed by the thalamus—that is, by one of the nervous centres of the affective life) may cause important changes, and thus we cannot consider the intellectual aspect of perception without taking into account all of the elements which go to make it up.

¹ Taken from A. Terrisse: "Combating illiteracy in a French West African project" (*Fundamental and Adult Education*, vol. 4, no. 4, p. 37, 1952, Unesco).

Many problems, however, still require clarification. As Wallon says (215):

It is much darker in the cinema than in the theatre, and the psychological effect of darkness on man as well as on animals is well known. On the other hand, spectators are much less inclined to talk than at the theatre, where, however, it is the actors' words which are essential. These differences in behaviour obviously have their significance. It would be necessary to make a comparative study of the cinema and other theatrical forms to determine the basic mechanisms of the influence of darkness.

We should not like to leave these general remarks on the audio-visual situation without calling the reader's attention to another fact which must be taken into consideration if we wish to give a complete explanation both of the effectiveness of the cinema and the contagiousness of emotions in a cinema audience. As a first approximation, we may say that in a room where there is a screen, focusing of attention implies (and we shall not analyse here in detail whether it is a question of cause or effect) a similar physical posture on the part of all present. A precise anatomical description is unnecessary here since each reader has the experience of the position to which we allude. Let us simply say that everyone is seated and has his head slightly raised since the centre of the screen must be somewhat above the average level of the spectators' heads. This similarity of posture (viewed statistically, as it were, and as a first approximation) corresponds to similar aspects in the distribution of tonus throughout the organism. We should like to refer in passing to the excellent analyses by H. Wallon (216) on this subject which helps us to understand better certain phenomena such as how the contagiousness of emotions takes place and why each individual's emotions are affected in depth.

Another form of this participation, which also produces similar or concerted reactions among the individuals present without, however, being the result of imitation, is emotion. It possesses a whole mechanism of expression whereby it is communicated from one person to another, producing a unity of tears, laughter, threat, violence, or panic among all present. Its power of invasion which precedes any reflection comes from the fact that its apparent features form part of a totality of automatic reactions, both motor and vegetative, which make up each type of emotion. But if they form an indissoluble part of these reactions and if they immediately give rise to the total process of emotion, their very contagiousness is an expressive mechanism which seems to have developed in order to ensure the necessary collectiveness of reactions in groups of an archaic type in which relationships

between individuals were still of a gregarious nature. This explains the fact that emotional violence increases with the number of participants and that the unleashing of their emotions cancels out any possibility of judgment, reflection, or intellectual calculation. Nothing proves better, however, that their function was considered useful among primitive peoples than the rites and ceremonies intended to bring them to a paroxysm and to pour into a single whirlpool all violence, all terror, and all individual energies.

The functional similarity of the automatisms proper to each emotion are ample explanation of the fact that similar reactions may be aroused among different individuals without any necessity for imitation. But how does it happen that they have developed a reciprocal sensitivity whereby manifestations on the part of one person arouse their equivalent in the other? A minimum of learning may have been necessary. The concordance of smiles between mother and child, no matter how early it may date from in the child's life, was preceded by smiles in which only the vegetative well-being of the infant was expressed. The smiling attentions of the mother contribute so constantly to this well-being that relationships are soon established between these two smiles which are selective, determinate, and exclusive. In a more general way, emotion is first felt in common as the result of an event or a situation which is capable of stimulating the automatisms among all present. Thus there is a fusion of what is recognized in others and simultaneously felt within oneself. The transition from one to the other quickly becomes inevitable.

It must not be forgotten that when one is seated in the darkness and in a comfortable chair, the body enjoys a certain type of muscular relaxation which has a definite influence on the level of the psychological threshold of receptivity. We shall see when we come to consider the factor of stimulation rate how spectators may be put to sleep. It should be added that good conditions of posture at a cinema projection constitute an important determining element of this phenomenon.

These remarks show how complex the audio-visual situation is and how contradictory some of its elements may be. A too brief analysis can lead only to a false idea of the psychological process which is set in motion. We must repeatedly emphasize that this complexity keeps us from jumping to hasty interpretations and makes us conscious of how great our ignorance still is.

B. THE AUDIO-VISUAL MESSAGE

The study which we shall later make of the reception of audio-visual messages presupposes a knowledge of their essential charac-

teristics. We may distinguish three aspects in this study: the physical qualities of messages, their structure and representational content, and the problem of their transmission.

1. *The physical qualities of messages*

A technical work on the subject might give high priority to this modest paragraph, and thus enable the author to discuss at length a large number of physical problems. We shall limit ourselves to recalling the data basic to our educational and psychological considerations. The reader who is interested in these questions may refer to the works listed in the bibliography (175, 176, 177). An auditory message transmitted by loudspeaker, whether at the cinema, from a tape recorder, or from a record-player, can be defined physically by its frequency, its amplitude, and its harmonic composition. Sounds reproduced by sound equipment are never exactly the same as sounds coming from the human voice or from an instrument because, whatever the technical quality of the recordings or the reproducing equipment, distortion is inevitable, and the full range of frequencies is never perfectly transmitted. We shall see the consequences of this for psychological problems when we come to study some of the aspects of auditory perception. We might add that progress now being made in this field is remarkable and that the possibilities of control and of high fidelity are being constantly improved. The quality of sound reproduction may be judged and measured by comparing its frequency response curve with that of the voice or the auditory capacity of the normal individual. To do this one has only to draw a graph with co-ordinates indicating sound frequencies along the abscissa (using a logarithmic scale) and sound intensity in decibels along the ordinate. The graph overleaf makes it possible to judge the improvement made in the quality of reproduction of records over a period of seven years.

It is obvious that any conclusions reached in studies on perception or comprehension will be related to the correct evaluation of the initial message.

In characterizing auditory messages we must not neglect to give due importance to the source or sources of the sound. Any experimental study should state these details, and good teaching will see to it that the sound originates from a position which gives maximum reception. Today everyone knows what precautions to take when installing loudspeakers in any room and the remarkable results that can be obtained when they are properly arranged. Stereophonic

music and the three-dimensional impression of certain radio or television broadcasts have made this clear.

The specifically physical characteristics of visual messages are as complex as those of sound messages. The screen is to light what the

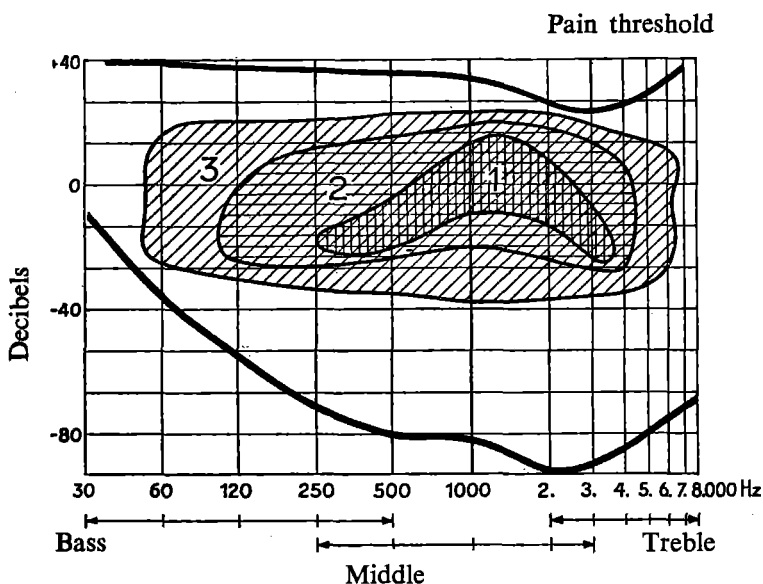

FIG. 2. ESTIMATION AND MEASUREMENT OF THE QUALITY OF REPRODUCTION OF SOUNDS

“Despite the technical progress made at different stages in the history of sound recording (records at 33 r.p.m., noiseless recording, high-fidelity recording), sound reproduction is still far from covering the entire auditory range of the human ear.” (Extract from the review *Atomes*, October 1951.)

1. 1928—Records, 33 r.p.m.
2. 1931—Noiseless recording.
3. 1935—High-fidelity recording.

loudspeaker is to electro-magnetic impulses: they are both media of representation. The position of the screen in a room corresponds to that of a loudspeaker, but whereas the latter has countless possible positions, only a rather limited spatial area is suitable for the former. The correct position for a screen is determined by the axis of the projector and by the level at which the spectators are sitting. If the screen is too low the rays of light are blocked by the spectators' heads; if it is placed too high it makes

them uncomfortable and soon causes fatigue. The size of the screen corresponds to the sound intensity of the loudspeaker, and the problems of maintaining quality when the messages are reproduced with amplification are similar for both of the representational media. It is important to remember that the frequent variation of the angle from which the pictures seen by the spectator have been taken, and dimensional changes in the picture reproduced—which, however, are always as large as the screen (going from distance shots to close-ups, with or without intermediate shots)—constitute original characteristics of the visual message in the audio-visual situation and introduce psycho-physiological processes which were formerly unknown.

A few words might be added with regard to the discontinuity of the message in the case of cinema projection. The speed of a projector is spoken of in frames per second, which means the number of stops that the film makes each second behind the aperture of the projector as the film is drawn through. For various reasons the early speed of sixteen images per second was abandoned. As Pieron states:

From the very beginnings of the cinema, helped by growing commercial interests, there has been a continuous striving for perfection in various directions, aimed principally at the creation of a more complete illusion of reality. The projection of stronger light made it necessary to use a faster speed in order to avoid an extremely unpleasant flickering caused by the rise in the critical flicker frequency (standard speed is 24 frames per second, which is generally doubled, giving 48 exposures).

The receiving surface of the luminous rays and the rôle of the screen as a medium of representation must be considered differently. Very few studies have been made so far on the influence of the relative positions of the three elements—projector, screen, and spectator. There are three possible situations, as shown in Fig. 3.

Messages emitted in these three situations have different characteristics, if only because the relative position of the three component elements is changed in each case. For example, whereas maximum darkness is required in the first and often in the third situation, it is desirable to have ambient light in the case of the second; for many reasons a television programme gains nothing by being watched in total darkness. An explanation of this will be given when we come to study the notion of the critical frequency of fusion of light impressions.

We must not leave the screen without recalling that the educator as well as the experimenter must take into consideration factors of 'directionality', as with a loudspeaker. The characteristics and intensity of the light rays or sound waves will depend upon their angle of emission: the smaller the angle, the better the results will be. It must be remembered, however, that audio-visual messages must be transmitted to a group that is usually fairly large, and an optimum balance must be found between the satisfactory quality of the message transmitted and the spatial coverage of the transmission.

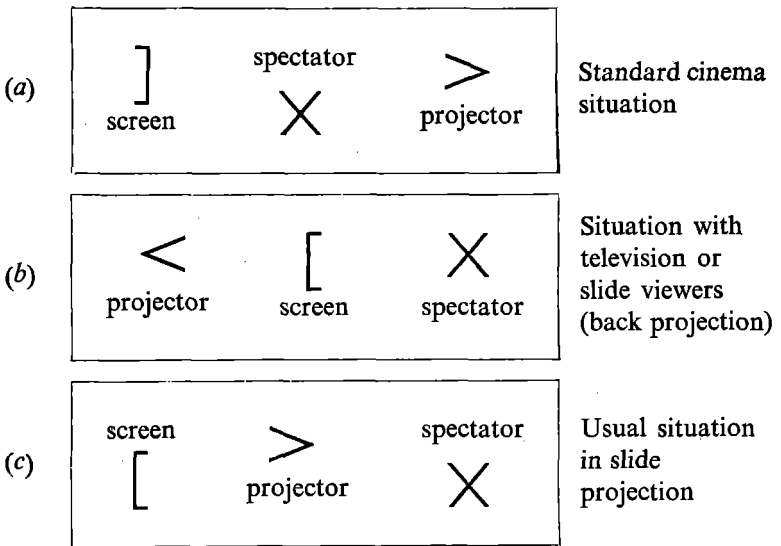

FIG. 3. INFLUENCE OF THE POSITION OF THE ELEMENTS OF A VISUAL MESSAGE ON PSYCHO-PHYSIOLOGICAL PROCESSES

This parallel between visual and sound messages could be continued, but we should risk falling into a mere verbal dialectic which could be harmful to scientific fact. Let us therefore consider only the message transmitted to us by the screen. It has a spatial and chromatic heterogeneity in common with messages that we receive from reality, but the rapid variations in its structure constitute a new phenomenon, the consequences of which are still far from being completely understood. It is true that it has an internal variation similar to that of natural messages, but less significant; sometimes,

as in the case of slide projection, this variation does not exist and the message emitted is poorer in content than the natural message. In the case of the cinema message, what concerns us here is the rapid succession of the different moments of the message considered as a whole (sequence or film). Here we find the basic difference between those visual messages which we are calling respectively 'natural' and 'cinema'. Natural messages constitute a continuous stream bound up with the individual's daily activities, connected to one another with a speed which depends upon the person himself and also upon precise psycho-physiological laws. Cinema messages, on the contrary, are connected arbitrarily—that is, as a function of new laws which motion-picture art can devise at will and which film directors juggle with according to their own temperaments. The rhythm, or length of time that each shot is shown, and angles of vision are imposed upon us, and the spectator is no longer free to choose either the field or duration of vision. We might make similar remarks with regard to sound because the rate of speech gives rise to phenomena of perception similar to those which we shall examine in the third part of Section II.

Let us return to the cinema message. Before any study can be made in this connection, it is necessary to understand the structure of the message in terms of total duration, number of shots, average length of each shot, the number and nature of the transition from one type of shot to another, the average length of each of these categories, and the length of shots which are of especial importance for purposes of comprehension. We know that there is an intensity threshold as well as a time threshold for a stimulus to be perceived. Experiments made recently by inserting in a reel of film frames that passed too quickly to be perceived have clarified these problems, and we now know that for best reception the rhythm of presentation—that is, the structure of the film—must vary according to the age of the spectators for whom it is intended.

We shall conclude this analysis of the characteristics of audio-visual messages by approaching this notion of threshold from another point of view. Sense organs have two thresholds—one at which perception begins, and the other beyond which stimulation is painful or dangerous or ineffective. If pupils are to be spared useless fatigue, it is important to know how to regulate the intensity of light or sound of an audio-visual message in such a way that it produces optimum stimulation without approaching the limit at which perception becomes painful or unbearable. Good teaching practice on

42 *Basic Phenomena of Perception*

the one hand and careful experiment on the other will take into account this mean value of intensity to be sought.

2. *Structure and representational content of the message*

The questions considered above, though recognized as important, formerly interested the physicist more than the teacher (who was none the less alive to them), but this is no longer true because the content of the message is of fundamental concern to teachers and, for that matter, to parents. Let us attempt to clarify our ideas on this subject by considering several of its aspects.

From the point of view of form there are three possibilities. First, the structure of messages may be similar to that of natural messages and the image (visual or auditory) may be a relatively faithful reproduction of reality. We know full well that no reproduction is ever an exact duplicate of reality because of the imperfection and limitation of recording and reproducing apparatus, and also because of the pre-selection made by the producer of the recording. The ideas expressed above concerning the general outline of perception make it clear that no recording device that exists at present can record, as man can, a large number of different messages. Although the sensitivity of an instrument may be greater than that of a sense organ, its extent is limited compared to cortical activity considered as a whole. Audio-visual messages are always less perfect than reality, but the extent of this imperfection is constantly being reduced; they are tending asymptotically towards a limit which becomes increasingly difficult to attain, at least with present techniques. In any case—and here we have a preview of paragraphs to come—these messages are usually perceived and recognized with ease, and the spectator finds himself in a situation which, all things considered, is relatively familiar to him.

The second possibility is that the audio-visual messages, while remaining natural to a certain degree, may be distorted in comparison with natural messages because they are not presented within the same system of co-ordinates: either the time scale is changed (by speeding up or slowing down), or else the spatial scale is unusual (by showing close-ups of microscopic objects enlarged to the size of the screen, or by amplifying an imperceptible noise till it sounds as loud as the banging of a hammer). These messages always express some aspect of reality, but the distortion is an important element, and the stimuli take on a strange aspect which can be assimilated only when the perception is transformed by the

mind. The audio-visual message enriches our appreciation of reality, but in order to be able to receive, perceive, and understand it, we must pass through stages similar to those that we went through in the successive conditionings to which we referred in our general outline.

The third possibility is that of messages which do not correspond to reality, but which are a pure fabrication of the producer. Forms of this type of message are extremely varied, from the superimposed lines that appear over a picture to analyse the structure of a machine or a landscape to the more surrealistic messages which go to make up certain avant-garde films and animated cartoons of all types. As in the preceding case, a new kind of perception must be learned, and children are often better at this than adults, because they still possess a malleability and an elasticity of learning that parents and educators have partly lost. This type of message, especially when it is a question of films or sound recordings which strive for an artistic effect, sets up special conditions of perception in which emotional aspects should not be neglected. This will enable us to understand more fully the wealth and complexity of the phenomenon of perception.

From an educational point of view there are other forms of classification which might be chosen, and we shall mention them here in passing because they will make it possible to discuss certain problems more precisely. From the standpoint of the individual's relations with reality and from the standpoint of education, the message may be considered under three main headings corresponding to three different purposes: the message may be intended as a document which will constitute a point of departure for perceptive and intellectual activity, and in this case its most important quality will be fidelity to the reality that it seeks to transcribe; or the audio-visual message may play the functional rôle of a catalyst by assisting the educator in his task or by enabling him to teach under favourable conditions, and in this case it will be the explanatory or facilitating power of the message which will be most highly valued; or the audio-visual message will have an affective function with a view to producing psychological activities in areas where emotion, intuition, or aesthetic perception predominate, in which case it is the power of suggestion or association and the protopathic elements of perception which become most significant.

Lastly, seen from without, audio-visual messages—and especially visual messages—may be classified in three types: the image which

44 *Basic Phenomena of Perception*

is self-sufficient (diascopic or episcopic), a number of images which make up a whole series (slides), and the cinema film which has the greatest power of stimulation and which also raises the greatest number of problems.

It was necessary to make these rather formal observations before going on to questions concerning the content of the audio-visual message transmitted by the screen or by the loudspeaker. Let us now consider this aspect by analysing first the notion of density of information content. There is usually a correlation between the richness of meaning intended by the producer of the audio-visual message and the richness of perception and mental activity which result from it. The educator or experimenter cannot fail to take this aspect into consideration in organizing his teaching or in analysing experimental variables. Any message has a content which either has been selected by its producer or else depends directly upon the reality that it represents. This is what might be called its 'density' of information (the term information not being taken here in its scientific and precise meaning), implying thereby not a relationship of two given factors as if it were a question of the physical notion of density, but rather the wealth of information transmitted. Certain images, for example, may represent only a single object or one person, whereas others express a more complex situation; one cinema shot may show only someone reading, whereas another shot may show more complicated behaviour such as reading, reflection, the expression of an emotion, etc.

This notion of the density of the audio-visual message may be considered from two different points of view which are quite closely related, as we indicated above. Every message has a power of psychological induction, as the diagram of the perceptive act at the beginning of this chapter showed; thus the density may be considered in relation to the number of perceptions, emotions, ideas, etc., which are produced in the person receiving the message. One might also compare an 'objective' density to a density of a 'phenomenological' order, the latter being, all things considered, the more important from both an educational and a scientific point of view. If this notion of phenomenological density is studied more closely, other aspects may be discerned which do not all have the same psychological consequences. There are three main situations here. To simplify our problem and clarify our presentation, let us suppose that the message contains an objective piece of information which we shall call *M* and that the psychological phenomena produced

may be called m_1, m_2, m_3 , etc., if they are related to M , and p_1, p_2 , etc., if they are not directly related to the content intended by the producer of the message:

1. The simplest case is the one in which M produces a single psychological process, m :



2. The next case is the one in which M produces several psychological phenomena directly related to it:

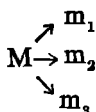

3. But there is also the case in which M produces perceptions, emotions, or ideas which do not seem to have a direct connection with it:

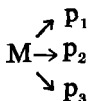

We shall not consider here the variations of these situations which can easily be imagined. It is clear that in the first case the audio-visual document is properly received and interpreted in an uncomplicated fashion; in the second case the document may be interpreted in several different ways, all of which are valid; lastly, in the third situation there is a complete cleavage between what the producer of the message wished to transmit and the interpretation of the messages received. This last situation does not belong exclusively to audio-visual techniques; many creators in the field of art are temporary victims of a similar lack of understanding.

The relationship between objective density and phenomenological density may be analysed in a different way on the basis of the preceding situations, and we then find two extreme possibilities.

The message M may produce in each individual (S_1, S_2, S_3) different processes:

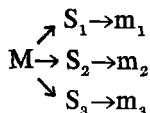

The message M may produce in the same individual the processes m_1, m_2, m_3 .

The second of these extreme cases enables spectators to discuss and perhaps come to an agreement on an interpretation which is accepted by everyone, since each one can imagine what the others have perceived. In the first extreme case, on the contrary, different interpretations are possible and several groups of individuals will be formed, each one being convinced that he has fully understood the message that was presented to him.

Without wishing to anticipate what will be said in the last part of this study, we may none the less note how important these considerations are for the teacher as well as for the person recording. Situation 1 above may be either the best or the worst from an educational point of view. It may be an excellent thing to reach uniformity in the interpretation of a message, and an educator will find a certain satisfaction in seeing a group react unanimously to what he wished to communicate. But there is a danger in this unanimity—which we must admit, is sometimes useful and even indispensable—because it is sometimes nothing more than the result of a double phenomenon: passivity of reception and lack of imagination. To say that a message *M* sets in motion a single process *m* can mean two different things: either that the message is so clear and well constructed or that it is so pregnant with meaning, to use Gestalt terms, that it automatically produces a single interpretation, whatever the individual conditions may be; alternatively, the uniformity of the reaction may also be the result of the mental poverty of the individual who is capable of establishing only a single relationship with a given message because of a lack of psychological dynamism due to constitutional causes or a bad education. The possible dangers of such a state of affairs can easily be surmised. The use of such audio-visual messages—and it must be remembered that we are discussing here extreme situations which are never found in such a form in reality—may lead to short-term results, but can, on the other hand, obscure one of the essential functions of education—that of developing to the fullest extent individual differentiation.

The second situation referred to above has more educational possibilities and is apt to lead to a fuller development of the individual on a personal level as well as socially. Man's psychological activity is basically characterized by the possibility which it gives him of transcending immediate reality, of projecting himself on to levels other than his own and of 'decentring', as Piaget would say. With animals or primitive individuals, a given stimulus produces a given

reaction almost mechanically. The educated man, on the contrary, is able to enrich the original message by seeing in it several valid meanings, or by considering it from different and, as it were, original points of view. Activity of this nature is not passive but creative, and thus essentially active. It develops a certain type of initiative and imagination, and considerably enriches the individual by accustoming him to envisage all possibilities and all likelihoods. Socially speaking, the multiplicity of indirect processes (situation 2) makes for meaningful social contacts and relevant discussions which may lead to a systematic classification of the value and importance of the different interpretations. Thus the individual transcends his personal reactions by adding a further dimension which he receives from social contact with the group. Such a use of audio-visual messages belongs to the tradition of liberal and liberating education, whereas the first case is closer to dogmatic and collective pedagogy.

However, we must not limit ourselves to purely educational considerations or give the impression of condemning audio-visual messages of type 1. It will easily be understood that the structures of type 1 and those of types 2 and 3 belong to documents of different types. The scientific document must be of type 1; the social or artistic document may be of type 2 and sometimes type 3. The misunderstood genius produces messages of type 3 which are found to belong to type 2 sometimes not until long after his death. We must not forget that the extreme situations described here have been given only for reasons of classification, and though they provide nothing more than a sketch they are useful in discussion.

From the point of view of genetic psychology, there is another aspect of the problem that must be considered in studying the general effectiveness of audio-visual messages. We spoke above of the correlation that exists between what we called 'objective' and 'phenomenological' density. This correlation, however, does not remain constant if the factor of age is taken into account. When considering a group of similar individuals above, we spoke of the notion of a phenomenological density of the message which varied according to individuals—that is, that their reactions may be diagrammed as shown overleaf.

Within a given group the number of processes produced among the different individuals is distributed in the form of a normal¹ curve. (See Fig. 4.)

¹ Normal distribution: a law of the distribution of errors which gives a graph in the form of a bell-shaped curve (Gaussian curve).

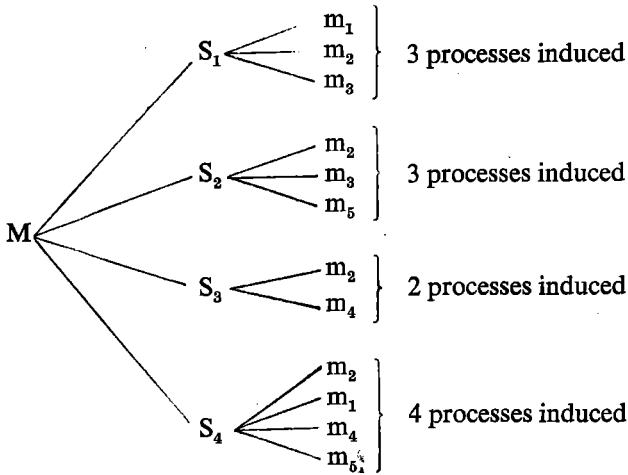

If we consider variations in age we find a different phenomenon which becomes a developmental curve. (See Fig. 5.) If the message M is rich enough in content to have adequate maximum phenomenological density, it can be observed that the latter increases with age in a more or less regular way. Experimental data on this point are lacking, but recent results in genetic psychology enable us to make an extrapolation which, however, is only theoretical and should be subjected to strict scientific verification. When educators say that a document gives the impression of a certain waste or that it exceeds the child's capacities, their meaning is quite clear: in the first case it means that the average number of processes produced for a given age is far inferior to the average phenomenological density for the adult; the second case is an example of situation 3 studied above, and the document is valueless for the educator. Audio-visual techniques should therefore be devised and used educationally in terms of the spectator's age if greater effectiveness is to be had for a lower expenditure of energy. It is understood that this adaptation does not mean that individuals should be given messages only at their own level or slightly lower, but that they should be accustomed to raising themselves to a higher level by using documents which have the power to bring about this growth instead of leading to a break in communication.

All these considerations now put us in a better position to approach a basic question: how shall we evaluate this 'density' which has been the point on which all of our discussion has turned?

The solution of this problem is difficult, and the present work can only suggest the direction in which research might be undertaken. The purpose of the analysis and distinctions which we have made is to facilitate later tasks and to avoid the quasi-problems which are so frequent in fields as complex as the one with which we are concerned here.

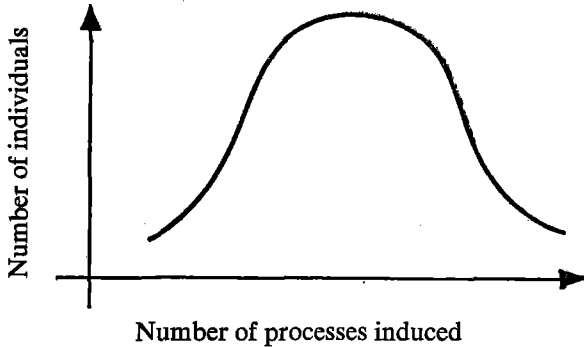

FIG. 4. GAUSSIAN CURVE SHOWING PSYCHOLOGICAL INDUCTION IN VARIOUS SUBJECTS

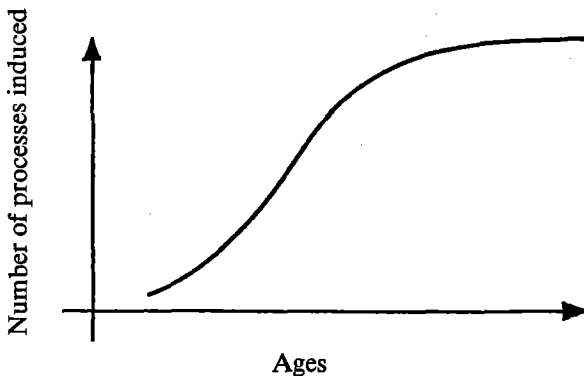

FIG. 5. RELATIONSHIP BETWEEN THE OBJECTIVE DENSITY OF THE MESSAGE AND THE AGE OF THE SUBJECTS

Without wishing to invoke a distinction similar to the one made by Kant between the noumenon and the phenomenon, let us simply say that it is possible to consider the density intended by the producer and the objective (or phenomenal, to give Kant his due)

density as not always being perfectly equated. This question, which belongs to the psychology of creation and to the dialectic existing between the creator and his work, will not be studied here; we shall be concerned only with the two aspects of density considered above. These remarks, however, lead us to a first basic affirmation: there is no absolute way of measuring the density of information in an audio-visual message. All we can hope to do is to determine in a relative way, by studying a group—in other words, by using statistical methods—an index that will give us a practical evaluation of the density of the message, though it must be recognized that it is difficult to establish criteria which are sufficiently objective to be respected by all the individuals who use them.

The following might be a way of determining experimentally the two aspects of the density of information in the message, and it will be seen that it is similar to what can be done by way of projection tests used in clinical psychology. An audio-visual document is presented to a group made up of N individuals (the larger N is, the better and more stable the evaluation will be). Each of the N individuals gives one or several interpretations of the message. We are not making a distinction here, as previously, between interpretations of types m_1, m_2, m_3 , etc., and those of types p_1, p_2, p_3 (situation 3), because the method required is a general one that can be applied readily to all cases. Let us use the letter i with a subscript varying from 0 to infinity, to indicate the interpretations given by the individuals. We then have:

Individual 1:	$M \longrightarrow$	i_1	i_2	i_3	i_{17}	i_{18}
Individual 2:	$M \longrightarrow$	i_1	i_2	i_3	i_{34}	i_{35}
Individual 3:	$M \longrightarrow$	i_1	i_2	i_3	i_{15}	i_{49}
.....							
Individual N:	$M \longrightarrow$	i_1	i_2	i_3	i_{25}	i_{72}

It will be noted that despite the qualitative and quantitative differences in the phenomena produced by the same message, there are in general a few interpretations resulting from the action of the message M which are common to all individuals. The number of identical interpretations made by the entire population or by a large fraction of it (75 per cent, for example) may constitute an index to its objective density. The average of the total number of interpretations made by each subject (together with an index of dispersal and a qualitative analysis) can be used to evaluate the phenomenological density of the message. As stated above, a distinction might be made

in this case between an average number of interpretations and the number of different interpretations. All of these numerical indexes must now be taken into consideration and correlated with a view to the general evaluation of the characteristic which concerns us here.

It will readily be seen that these measurements are relative to the group to which the individual belongs, taken as a standard of reference, and this point should be made clear in scientific estimates and applications. The phenomena of disparity between the message and the comprehension of young children exist only to the extent in which a measurable estimate of the density has been made by an adult educator. It may therefore be reasonably assumed that a carefully chosen group of cultured adults can serve as the basis for a first series of measurements which can be used in undertaking and properly interpreting others. In our opinion this results from there being an absolute value for the density of information of every message.

Such measurements, which can be made only with sufficient time and personnel, give a more exact knowledge of the message being used and make possible the scientific study of audio-visual situations. It is evident that all the precautions known to research workers who are familiar with statistical methods should be taken, and that results of a mathematical nature that are obtained should always have a relative value attributed to them.

The content of messages must not be considered solely from the point of view of density; it must also be studied in its sequential aspect which is particularly important where audio-visual techniques are concerned. The whole message is made up of a series of successive messages bound together by an internal law of connection with a view to a particular action. We shall not concern ourselves with the laws of film construction, but with the characteristics of documents such as slides or moving films used for more directly educational purposes or, more specifically, for learning some particular subject. Assuming that everyone agrees about the need for progression in the constant flow of new information contained in successive messages, we may go on to discuss the form of this progression. Here we find two concepts which are diametrically opposed and spring from two different theoretical systems.

In one case a logical law of composition, almost in the Cartesian sense of the term, is applied. Between message M_1 and message M_{i+1} the difference of information must be as small as possible so that it can be discovered or assimilated easily by the individual; such

a construction ensures continuity and satisfies the logical needs of the adult. Modern programmed learning is based on this approach. The message in its entirety is thus made up of a series of progressive additions designed to facilitate the communication of the ideas that the producer wishes to transmit, or else to help in the progressive building up of an automatism. The activity of the receiving individual consists in discovering the slight difference of content which exists between the successive stages of the message so as to assimilate it into his previous knowledge or potential for knowledge. In some cases this effort at discovery is reduced to a minimum, and the individual has nothing to do but let himself be guided step by step by the audio-visual message. Certain educators find such a document structure good in many ways. They stress the regularity of progression, the individual's continual discovery of something new, and the alertness of attention and eagerness for the series of images required by it. This is the application of the principle of 'suspense' to education.

A document may be constructed in a way quite different from the preceding one not because of its illogical nature, but because it is on the whole in greater agreement with the laws of perception and mental processes such as we know them. Knowledge of a certain reality is not gained—or at least rarely—by simple addition but by a progressive synthesis of new points of view which regularly enlarge the knowledge that one has of this reality and at the same time change it qualitatively by subjecting it successively to different levels of psychological analysis. To know an object is to know it from every point of view and to recognize it no matter how it is presented; it is also to know its composition, structure, and functional possibilities. One does not know a watch by examining first of all the dial, then the numbers on it, then the hands, etc. Psychologists have shown that our perception is always of a syncretic nature, and that the analysis made by an individual in the course of learning has nothing to do with logic in the Cartesian sense of the term. The composition of an audio-visual message should therefore make possible this analytic activity which is part of the overall development of the child, and the successive phases of the analysis should be functionally related to a psychological activity whereby each individual may discover in the document a message corresponding to his level of perception and comprehension. It will not always be possible to obtain unanimity and different individuals will analyse a document differently, but each one will acquire the habit

of reacting in a personal way to the messages received, and we shall come closer to the normal laws of actual psychological operation. Further on we shall examine the differences between true perception and perception in the audio-visual situation.

We propose to conclude this review of the characteristics of audio-visual messages by a few remarks on the graphic style in which they are presented. This is not the time to study the rôle of cinema style and syntax properly so called; we shall do so in Chapter 3. Here we should like to consider only the internal characteristics of the image as it is presented. The range of possibilities runs from the perfect reproduction of reality (as is virtually the case with photography) to a schematic representation by the use of a few lines which create an impression using strictly limited means. To put it more concretely, the audio-visual message may be constituted by a cinema reproduction of a man drinking or by an animated drawing of a figure resembling a man or by a few lines indicating a raised arm, a glass, and a tilted head, the whole suggesting very graphically a man in the act of drinking. It is not necessary to point out here that many advertising films and animated cartoons belong to the latter categories. This question is not only of technical or artistic interest; it also raises certain problems which directly affect the psychologist and the educator. We see immediately that in a certain sense the more the message has been simplified and made schematic by the artist, the more the individual is obliged to furnish an effort of interpretation. And contrary to the opinion held by some, beyond a certain limit schematization does not lead to uniformity of reception and perception, but either to incomprehension or to the stimulation of a wide variety of mental processes caused by the oversimplified representation of the message which necessitates too great an effort at reconstitution. Inversely, a perfect image of reality may fail to bring out clearly that part of the message which is meant to be stressed. Everyone has heard the comment of the child who had been placed on the back of a mule to watch the wonderful Gavarnie circus: what had struck him most—and was perhaps of greatest interest to him—was the movement of the two long ears of the animal he was seated upon! It is frequently observed that children see in pictures, or simply in reality, details which have no importance for adults and, conversely, do not perceive what appears as essential to us. Thus it is quite understandable that educators or producers of films are concerned with simplifying the message and reducing it to its essence by eliminating useless details or by making a schematic

54 *Basic Phenomena of Perception*

diagram of reality in order to bring out the elements to be emphasized. These then are two types of simplification which are of different value depending upon the age levels being considered, and which do not play the same rôle as far as their psychological effects are concerned. In one case the density of information is reduced in order to concentrate attention on that part of the message which seems most important to the producer, and parts of the document which seem useless are cut. We use the word 'seem' intentionally because—and here we refer to our general outline of perception—perception has its own unity, and interpretation may go in quite different directions under the influence of a qualitative variation that may be quite small. This is an important and difficult point—namely, the effect upon perception, which is a conscious phenomenon, of all the messages which do not reach the threshold of consciousness, but which do, none the less, exert their influence. If the message in the second case is originally a schematic or stylized document, we again come upon the possible distortion mentioned above between the intention of the creator and the final result; in particular, a 'formal' or a fantastic style may complicate perception and even make it impossible before a certain age; the number of known facts and necessary associations as well as the level of the intellectual processes required are such that the messages received are interpreted under poor conditions, and the perception produced is in complete disharmony with the objective content of the message. Here again we must be wary of extreme situations and must judge them in relation to the overall context and the age and possibilities of the audience for which the audio-visual messages are intended. Another factor that should not be lost sight of is the degree of familiarity which the spectators have with animated diagrams. Judgments must be made, however, in rather a broad framework. Facile reception and perception of given messages may have a tendency to develop passivity and especially a certain standardization of structure and content in the thought processes of children or adults. We are here in a domain of far-reaching consequences which are sometimes neglected for the sake of immediate results, and it is difficult to say scientifically what will happen in every case. We shall enlarge upon this question in later paragraphs.

3. The transmission of messages

We shall leave the physicists and engineers to analyse the ways in which audio-visual messages are carried from their point of

origin (loudspeaker or screen) to the subject. Without going into purely technical problems, we should like to make certain psychological observations bearing in mind modern cybernetic concepts. A message is coded, transmitted, and then decoded, and each of these stages has been thoroughly and profitably analysed. The general theory which has resulted from these analyses can be applied in the different fields of physiology, psychology, and sociology. We shall not apply here the mathematical theory of information (information being taken in the modern and scientific sense of the term) both because this would require explanations which would be comprehensible only to a very limited public, and also because our ideas in this connection are not yet sufficiently precise. We shall therefore make a somewhat simplified application of the general concepts to the problem with which we are concerned, but this will permit us none the less to raise certain questions of educational and psychological interest.

Morse telegraphy is often used as an example to explain and analyse the transmission of a message: each letter is replaced by a certain number of dots and dashes properly structured (coding). These elements are transmitted electrically and are translated back into words at the other end of the line (decoding). If this outline is clear we may say without fear of contradiction that it simplifies reality considerably, sometimes to the point of over-simplification. In point of fact, to consider only the coding, a closer analysis reveals the following stages—letters, translation into dots and dashes either by a machine or by a human being, corresponding mechanical movements (functioning of the Morse key), various electrical phenomena of opening and closing the circuit, and initiation of the electric current. Each of these movements has its own unity, its own dynamics, and each of them introduces into the overall process distortions, 'noises', static and artificial elements which it would be relatively easy to locate.

The same is true for the audio-visual message in which the different phases of coding, transmission, and decoding are not always as clear as one might think. We shall start with the screen or the loudspeaker (which, it might be said in passing, themselves constitute a stage in the decoding of light rays coming from the projector or of electric impulses transmitted through the apparatus), which we shall take arbitrarily as the origin of the audio-visual messages. The coding of the message then takes place on two successive and different levels—physical coding and physiological

coding. Light waves or sound waves leaving the screen or the loudspeaker belong to the first form. Contact between these waves and the sense organs transforms the first type of coding into the second type which will be transmitted to the cerebral cortex as we have explained above. Everyone knows what happens when the auditory messages lag behind the visual messages due to the difference in the speeds of the two wave trains. A similar lag is sometimes used intentionally for artistic purposes, but it makes reception difficult and is apt to upset the overall audio-visual message completely. This is what happens in films which have become desynchronized, for example. In some of the older or poorly equipped cinemas the spectator often had to wait a fraction of a second to hear what the actor had said, and the time lag between gestures and sound sometimes produced strange and amusing effects. Thus, despite the general impression of simplicity, the transmission of messages is really based upon very complex phenomena which are only now beginning to be analysed and of which the inter-relationships are still far from being clearly understood. The words used to describe the different elements of the process, for example, are used quite relatively. Sensory reception may refer to a decoding of the light wave and, at the same time, a recoding as far as nerve transmission is concerned. But distortions can be analysed and understood much more precisely and finely than before because the general principles of the theory of the transmission of information can be applied to the concrete and specific analyses which had already been made. Thus a whole new field is opening up in audio-visual research, and its psychological consequences will make our present knowledge seem quite naïve and elementary. But a more precise understanding of the processes of coding and transmission will give the educator greater possibilities for using audio-visual techniques and will increase their effectiveness. The causes of distortion and interference will be more easily discovered, and the margin of uncertainty will be considerably reduced.

The educational psychologist, however, is interested in another aspect of the transmission of audio-visual messages—namely, its external form. There are three possible situations:

1. The message may be transmitted to a group collectively, as is the case in the cinema situation. Each individual receives the same messages at the same time and under relatively similar conditions, though each person is at a

different point in space, and this may be important. A situation of this type produces individual and social phenomena that are the outcome of an identical reception situation which poses no problem for the spectators.

2. The message may be transmitted to members of a group individually. This is the situation in which each individual in a group can receive the message privately by means of headphones or his own portable receiving apparatus. Although the individual psychological phenomena are approximately the same in this case (which has not yet been thoroughly studied because it is still technically infrequent) as in the preceding situation, this is not true of its social aspects. The reception situation is not as strictly identical as in the previous case with regard to position, for example, and identity of situation is not one of the essential features of this situation. Individuals are thus seen turning to one another to make sure that they are not alone in having understood or felt the message, and the expression of emotions has particular characteristics which it did not have in the preceding situation.
3. The third situation is one in which the individuals who are receiving the same message are separated from one another and do not constitute a receiving group. Here again, although the individual phenomena are similar to those produced in the other situations, the social aspects are quite different, if not absent, as are also the external manifestations of emotion.

It may be stated without hesitation that the reception of messages transmitted in each of these three situations may, in certain cases, have rather important qualitative differences in individual perceptions and in the phenomena of comprehension. Technical advances still have many new surprises in store for us, and new psychological analyses will be necessary, because, as we have said, the same messages received in different situations set different psychological processes in motion.

C. THE INDIVIDUAL

Let us now turn to the individual. What exactly happens to perception in the audio-visual situation? Without spending too much time on this point, we should stress the essential difference that

exists between the perception of reality and perception from a screen. Here we may quote the views of H. Piéron (177):

Perception is essentially an anticipation. Its usefulness is that it makes us anticipate the properties of the object which has just entered our field of perception. Sometimes a very rough sensation is enough to enable us to perceive qualities in the object which are still not apparent, provided that reference to familiar aspects is possible. A sensation becomes the clue to something which exists around us and causes us to deduce its properties.

Thus, Piéron continues, perception has two stages—the first stage which is the warning, as it were, that something is present. We begin by knowing that someone is standing in the doorway, without knowing exactly who it is, and our perception then develops or is verified by vision, or by the other senses; but perception does not require a totality of sensations all at once. Perception is something which makes us presume the presence of some person, object, or thing, and it is only progressively that we grasp the details and qualities of this object of perception. We anticipate the reality of the object and gradually verify that our anticipation actually conforms to that object.

It is evident that the situation of the spectator before the screen is the opposite of the one described above. Wallon (215) explains this difference quite well:

What a film shows us is a successive series of images related to the same object, images which we are supposed to follow one by one in the order in which they are presented and which we must make into an integral whole in order to constitute an image of the object in all its facets, an image of a relationship from all its angles, or a person in all his aspects. But the succession of images is a succession of particular images which we must record and fuse together by an effect of our memory, an immediate memory no doubt, but memory none the less. We must not lose the thread of the images because the idea of the object, the identification of places and persons, and the understanding of scenes depend upon it. This then is an action opposite to the anticipation in perception which begins with a general view, a vague grasp of the object which we seize in its potentiality. Its first image is already pregnant with all the prolongations, all the suppositions, and all the verifications which we can make in connection with this image. There is thus a kind of opposition between the image of a film and perceptive anticipation.

If we look at this from an educational point of view, we realize that a 'passive' component has been introduced into perceptual activity. The mental activity of the individual is no longer the result

of an initiative on his part, but of a process which is imposed upon him from without. The activity on the part of the spectator is the result of an initial outside stimulus and is quite apt to decline into a second-rate activity.

This has serious consequences for the child who becomes habituated by the cinema to a mode of perception which is quite different from everyday perception. Let us go back for a moment to the notions of coding and decoding referred to above and see one of the major problems facing present-day education. As we said, perception might be compared to a broad system of decoding which takes place at different levels and different moments. One of the essential principles of coding is that of economy. In a well-constructed code the phenomena of redundancy are reduced to a minimum. The perceptual and intellectual activity of the individual consists in discovering, on the basis of a minimum number of signals, the meaning of the message being transmitted. This activity is similar to that of synthesis in that a whole has to be constructed using a certain number of separate elements. In a sense this is just the opposite of syncretic activity such as psychologists have described it. We do not believe, however, that there is any opposition between the two, and we shall explain why. The basis of all perceptual situations is the message to be interpreted (*cf.*, the general principles set forth above)—that is, each message has a 'certain' meaning. As we have already explained, the complexity and value of this interpretation will depend upon the individual himself, on his age, his past, and his previous experiences. Perfect decoding implies a most highly developed perceptual activity in which the interpretation of messages is based upon a particularly intense intellectual activity. This is what the detective does when he discovers a criminal on the strength of only a few clues. But what happens in such cases? Each sign gives rise to one or more hypotheses, and each of these hypotheses is retained or rejected in the light of the totality of the clues in the individual's possession. In the case of syncretic perception, especially where the young child is concerned, each message gives rise to a single interpretation or a small number of interpretations which cannot be verified by a parallel intellectual activity and which are lacking in complexity because of the inexperience of the individual. This sometimes surprises the adult who is accustomed to judge things from a more logical point of view.

To this must be added, as Meili has pointed out, another dimension which makes it possible to resolve the apparent contradiction

between syncretic perception and 'pointillist' perception. Let us stress, as he does, that first of all syncretism is not at all, as Demoor and Jonckere too often assert, perception of a 'type' and, secondly, that a detail is not necessarily a part and is probably never an element in the child's perception. The different forms of perception might therefore be found along an imaginary line drawn between the opposing extremes of *syncretic perception* and *pointillist perception*. Organically structured perceptions of wholes may be closer to one or the other of these two extremes. The essential difference between the child's perception and that of the adult is that the former is more frequently closer to one of the extreme forms than the latter. But how is it that the same presentation which gives rise to an organically structured perception in the adult sometimes produces in the child a syncretic perception and sometimes a pointillist perception? The ideas of the Gestalt school of psychology will help us to answer this question. A distinction must be made between two aspects of total perception, between form and structure—*i.e.*, between its conscious aspect and its objective aspect, including the system uniting its elements and their mutual relationships. The structure may be operative without being perceived. It is to form, Meili continues, what the chemical composition of a substance is to its observable qualities. Form and structure may be simple or complex, but simplicity of form and simplicity of structure need not necessarily coincide. Furthermore, the structure may be strong or weak. It is weak when the unity of the whole is rigidly expressed in the convergence of its elements. Thus we can easily understand that the child will perceive in a syncretic and overall way when he is faced with a whole which has a simple form and at the same time a strong and not very complex structure; and he will perceive in a fragmentary and pointillist way whenever he is faced with a whole having a complex and weak structure which is without meaning for him (28).

The audio-visual message should therefore be constructed with these remarks in mind in order to make it possible for the child to develop his perceptual activity step by step. Unfortunately films for children are too often made in the same way as those intended for adults, and it is easy to see why difficulties of comprehension arise.

We must not forget that all this intellectual activity which is inseparable from perceptual activity at this level takes place at a rhythm which is proper to the child, and this rhythm is not neces-

sarily the one at which the message is presented. This may give rise to a series of perceptual errors due to incorrect interpretations of messages which are presented too rapidly. Although it is often unconscious, the back and forth movement between message and hypothesis requires a rapidity of psychological processes which develops with age and habit. Young children of today who are familiar with the cinema have a perceptual capacity which is relatively greater than that of adults for whom the cinema has become an element of social life. The problem however still requires study. As Wallon points out (215):

An even more elementary problem which does not seem to have been thoroughly studied is the power of synthesis within the time-span presupposed by the cinema. At what age does the child begin to be capable of making syntheses of the numerous images? This question should be decided before introducing the cinema into nursery school. At what age can he make a synthesis of the details of an object or scene? At what age can he make a synthesis of episodes? Music has its units of measurement for length of notes, measures, and tempo; it has its counterpoint and melody by which it attracts, holds, and captivates the listener. May not the cinema too have a chromatic scale all of its own which is still not well understood?

The problem of the speed of presentation of stimuli has been studied from a different point of view by Professor E. Mira y López, and here is a portion of an unpublished text which he has been kind enough to show us:

Since 1932 we have been struck by individual differences in the degree of precision and perceptive capacity of a group of policemen who submitted to a film test to determine their capacity as witnesses. The results of this test (164) prompted us to undertake further research to analyse the factors responsible for such differences which were particularly striking, because they were observed in a group that was homogeneous so far as age, culture, and motivation were concerned.

Since that time we have observed empirically that most of the adults who fall asleep in the cinema are either elderly or depressed persons, or else individuals who are 'slow' in their movements and in their verbal expression. Soon we were able to explain this behaviour by the fact of a defensive cortical inhibition against the excessive rapidity of the moving pictures. We had occasion to verify this hypothesis by showing a film in slow motion to an audience made up of the residents of the Park Refuge in Barcelona, where the average age was above seventy. Not a single spectator fell asleep.

It is also a fact that 'nervous' individuals like change and are considered 'unstable', whereas calm and 'cold' persons prefer to exhaust sources of pleasure or get to the bottom of problems patiently. We demonstrated some time ago in 1921 (*cf.*, *Annales de l'Institut d'Orientation Professionnelle*, Nos. 1 and 2) that 'tachypsychic' individuals suffer more from monotony because they are more quickly saturated by their perceptions, whereas the 'bradypsychic' are prone to order and perseverance because they lack the capacity to understand and adapt easily to rapid or sudden changes in the field of perception.

All of these facts coincide to justify the hypothesis according to which in any film projection or audition whatsoever, only a portion of the audience (approximately two-thirds) will be able to follow the rhythm of the message throughout the entire length of the presentation. The other third will be above or below the level of the script because it is presented too slowly or too fast in relation to their personal speed of perception. If, therefore, an audio-visual presentation is to benefit an entire audience, the spectators must be classed into three categories—'tachypsychic', 'normopsychic' and 'bradypsychic'—and the speed of presentation must be regulated according to their average perception and reaction time.

We asked Professor Esther Assunção in School No. 7 of the Prefecture of Belo Horizonte to select a group of 30 pupils in the upper primary levels whose I.Q. was approximately normal (between 90 and 110 on the Binet-Terman scale). These pupils were requested first to pound on their desks in a regular way at their own speed for 30 seconds. The number of blows was recorded, and the pupils were classified in three groups (*a*) those who had struck between 26 and 40 blows; (*b*) those between 40 and 60; and (*c*) those between 60 and 106 blows. The following day these pupils were asked to estimate three periods of time of 5, 15, and 28 seconds, and again they were classified in three groups: (*a*) those who had underestimated the length of the periods; (*b*) those whose judgment had been approximately correct; (*c*) those who had overestimated the length of the periods. The last group was the most numerous: 16 pupils. Linear correlation between the number of blows a pupil made and his tendency to overestimate length of time (that is, to judge a period as being longer than it really was) proved to be positive and significant to 1 per cent. ($r=0.74$). This meant that the pupils who struck their desks at the fastest rate were also those for whom time passed most quickly, and consequently these pupils should be considered as 'tachypsychic'. Linear correlation between the number of blows struck by the 6 pupils of group (*a*) and the number of seconds given as their estimates of duration (in the second experiment) was also positive. Those who spontaneously struck fewer blows in the allotted time also estimated duration as being shorter than it was in reality; because of the small number

of cases we do not feel that these results may be considered valid ($r+0.52$ percentage error $=0.15$).

Two weeks later the 30 pupils were shown a film of a trip along the Amazon river. This 35-mm. film was shown at a normal speed. It had 37 scenes and lasted 10 minutes and 20 seconds. Immediately following it pupils were given a questionnaire meant to gauge their capacity for visual comprehension. This questionnaire consisted of 30 very precise questions concerning the number of different scenes which were outstanding in the film. On an average, group (a) had 12 correct answers, group (b) had 25, and group (c) had only 21.

Unfortunately, we were unable to continue these experiments, but we are certain nevertheless that the normal rate of presentation was too high to enable all the spectators to take full advantage of the projection. And we are convinced that the same is true when it comes to auditory stimulation.

Let us conclude these general indications with a remark concerning the unity of the phenomenon of perception. We have stressed the fact that the interpretation of messages received represents a real synthesis at the cortical level no matter what sensory channel has been used in transmitting it. In the audio-visual situation, as the term itself clearly indicates, auditory and visual messages are predominant. To be more specific, the interpretation of messages coming from the screen or from a loudspeaker obeys the laws referred to above, and other sensations come into play in the final process—*e.g.*, contact with one's neighbour, particular odours in the room, and so on. But the reality on the screen is not translated only in the terms of 'audio' and 'visual'. The spectator must re-create a situation not only with the limited number of messages compared to what he would receive from reality itself, but also deprived of certain types of messages which, had they been present, might have added to the correct perception. Such is the case when a flower is shown without fragrance or a forge without heat or a cave without the barotaxic impression it would cause. Spectators are apt to acquire the bad habit of taking into account too exclusively certain messages and not being interested in any others. On the contrary, we should always consider the different aspects of human phenomena. The too frequent presentation of audio-visual messages may result in developing an intense psychological activity which makes it possible to reconstruct reality on the basis of insufficient messages. There is a danger that this may reduce sensitivity in areas which are less often stimulated. The seriousness of such a development can easily be imagined. Experiments have shown that animals

raised in complete darkness lose all or part of their visual sensitivity, and that children accustomed to hearing only bass notes become deaf to treble notes. The educator must, therefore, be careful to develop the forms of sensitivity which are absent in the audio-visual situation so that perception on the whole will not become gradually reduced due to the too frequent use of records, slides, or films.

III. VISUAL PERCEPTION

In order to avoid overburdening a text which is already quite complex, we tried to cover certain general problems related to perception in the overall audio-visual situation at the end of Section II. What was said there naturally applies to what follows here. But as far as possible we must try to classify facts, scientific results, and hypotheses in an effort to clarify what is highly complex and difficult to analyse in practice. We shall, therefore, group together in this section a series of studies related particularly to the visual function, and we shall begin by summarizing results obtained from the physics and chemistry of light stimulation.

PHYSIOLOGICAL PROCESSES RELATED TO VISION

We cannot go fully into the study of the processes which research has analysed in detail in connection with the eye, and particularly the retina. It is nevertheless necessary to recall a few facts in order to explain other phenomena which are regularly encountered in audio-visual situations.

It is well known that the physical and chemical phenomena which take place in the retina require a relatively long time compared to those which take place in the auditory or tactile senses. Piéron (176), to whom we are indebted for the following information, points out that intermediary mechanisms in human visual perception cause a lag of some $4/100$ of a second, which is considerable compared to perception through other organs. As is well known, the sound track of a film always runs ahead of the corresponding image, and this visual delay may be one of the justifications for this being so. This rather long duration required for the transmission of visual messages is linked to a chemical phenomenon. This has led Selig Hecht to devise a general formula for a process of light stimulation in two stages in which a molecule of a photosensitive substance is decomposed by light into two molecules P and A, which tend to re-

constitute the original molecule by catalysing a chemical reaction with a body L giving rise to a stimulating substance T which sets in motion the nerve impulse:

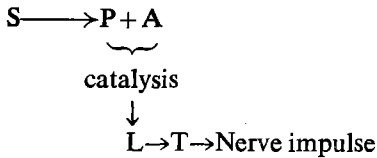

This is not leading us away from our problem, because the complexity and slowness of the process explains, as Piéron says, "the facility with which intermittent stimulations merge, in relation to the persistence of sensations produced by successive impingements".

Here we have a second phenomenon which has been made possible by the first one. Many people still explain perception of motion-picture images through the persistence of light impressions without realizing that if this explanation were exact, no movement would be clearly perceived on the screen. Instead, we would see a 'blur' similar to what is observed when a time exposure is made in photographing a meteor. Physiological psychologists have shown that intermittent stimulations blend together and give the impression of continuity provided the rhythm of stimulus is kept within certain limits ("this frequency may vary from 4 or 5 separate stimulations to 100 per second, assuming that the image flash lasts as long as the period between two flashes"), and that the light is of a certain intensity. "If the relationship between the two phases is varied, but the light intensity kept at its same level (that is, perceived as the same when the images are blended) the critical flicker frequency rises in proportion to the relative length of intermittence." On the other hand, the critical flicker frequency also depends on the intensity of light, being less as the light is decreased, and increasing proportionately with every fractional increase in the intensity of the light.

Let us set aside the other analyses and discussions concerning these phenomena, and draw some conclusions about visual perception in the cinematographic situation. Contrary to what takes place in auditory perception, stimuli received at a low frequency rate can be blended if the intensity is not too strong. It is for this reason that the increase in light used for cinema projection made it necessary to increase the speed of projection in order to avoid a disagreeable flickering due to a rise in the critical flicker frequency threshold

(24 frames per second, and sometimes even 48, depending upon the projection apparatus, each frame being held for two intermittent periods). This flickering sometimes appears when one watches the screen obliquely or when one is not seated in a position of optimum vision. (This is especially true in the case of television.) Thus we must seek the best conditions for good visual perception on the basis of physiological facts in order to eliminate causes of fatigue which reduce or interfere with the child's attention (see below the results of L. Leboutet).

SOME RESULTS OBTAINED IN THE FIELD OF NEUROPHYSIOLOGY

Without making a detailed and profound study of physiological phenomena—which would be neither within the scope of our general educational and psychological approach to our subject, nor within our competence—we must none the less mention the excellent work carried out by several teams of specialists in the field of electro-encephalography.¹ Gastaut and Roger (86) are careful to give the following subtitle to their article, "Possible Applications to Filmology". Starting with intermittent light stimulation (stroboscopic effect), they study variations in cerebral rhythms and call attention to a certain number of facts that classical physiology had not analysed. "Facts all show that the optical channels are not so wonderfully isolated and independent as is often thought, but that they have multiple ramifications and points of junction which unite them to many structures throughout the different cerebral layers." This simple remark takes on a particular importance for the psychologist since the path followed by visual excitation does not produce only visual perception but also a series of parallel phenomena which must be analysed and understood if one wishes to understand fully the mechanism of cinematographic effects. At the end of the first study the authors conclude:

1. That intermittent light stimulation alone may have very important psychological, somatic, and electro-encephalographic effects, as is shown by an analysis of the different tracings obtained from leads placed over different regions of the brain (frontal-central right and left, central-temporal right and left, temporal-occipital right and left).

2. That these effects are largely produced by impulses being

¹ We are here presuming that the reader is familiar with the basic facts of electro-encephalography, such as the taking of an electro-encephalogram, its various rhythms (frequencies and amplitudes), etc.

transmitted through visual channels towards cerebral areas responsible for different functions; hence the complexity of the behaviour observed.

3. That these impulses depend upon: (a) the state of the individual's nervous excitability, which is particularly high among those who are emotionally unstable, the 'neuro-labiles' and consequently among a large number of persons, from the simple 'nervous' individual to the idiopathic epileptic; (b) the interval between stimulating flashes which should be somewhere between 40 and 100 milliseconds, with the optimum being approximately 70 milliseconds (corresponding to a cerebral rhythm of 15 c/s).

Without affirming the existence of a cause and effect relationship, the authors leave this possibility open to research by stating, in 1951 (86):

We are not yet in a position to estimate to what extent these findings, obtained with a special stimulator, may be applicable to the intermittent light stimulation from moving films. However, if the intensity of light from a screen is much lower than that of our lamp, and if its field changes at every moment instead of remaining constant, the frequency of repetition of the film stimuli will have harmonic relationships with the frequencies which proved effective in the experiments (96 and 48 are harmonics of 24, which is an effective frequency for producing induced responses, and is also the standard speed of projection for sound films). It is well known that film stimuli may cause an epileptic seizure in certain idiopathic epileptics who are sensitive to intermittent light stimulation, and many of our patients cannot tolerate the cinema.

This preliminary work, which is of considerable importance, should be continued, and if the so-called 'activation' methods were used (with slow injection of cardiazol or some anaesthetic), a new avenue would be opened up to research—namely, that of recording an electro-encephalogram while a cinema projection was going on (54). Experimenters could select *control films* which were 'neutral' or seemed to have the least affective potential, and then *test films* chosen or produced for the sake of the violence of the psychological—usually emotional—reactions which they would be apt to arouse.

We shall not go into technical discussions about the modifications of the electro-encephalogram because we do not wish to stray from the psychological field, but we must mention certain results which enable us to understand better the general phenomena which concern us here. Among those which we cannot pass over in silence is that which is called 'motor postural induction' resulting from the observation of facts which are difficult to interpret. We are obliged to enter into some detail here because it is rather frequent to find a

Rolandic rhythm developing in the form of a succession of arches while the film is being projected. We might recall that this is a rhythm with a frequency very close to that of the alpha rhythm made up of waves of asymmetrical and non-sinusoidal form, which give it the overall appearance of a series of arches. It seems that cinema projection does not cause the arched rhythm to appear in individuals who do not exhibit one when they are at rest, but it is certain that it favours the development of this activity in individuals who exhibited it formerly or who were apt to exhibit it under certain conditions. As far as the increase in the arched rhythm is concerned, two hypotheses are possible:

(a) The content of the cinema projection may positively increase the arched rhythm by causing psychical or psychosomatic reactions which are favourable to the development of this rhythm in the Rolandic area of the cortex.

(b) The cinema projection may play only a secondary rôle in bringing about a state of muscular relaxation which may counteract the blocking of the arched rhythm.

It is likely that both of these hypotheses are valid, and that the two mechanisms may be added together. Observation of the second one, however, seems particularly important here.

We must emphasize, however, the process of blocking the arched rhythm which is observed when the spectator identifies himself with one of the moving characters projected on the screen. It has been proposed to use the expression *motor-postural induction* for certain aspects of the effect produced by this film phenomenon (55) during a cinema projection:

It would seem that under the influence of the film presentation we engage our 'consent' and its psycho-physiological conditions still further in an existence which becomes ours at some particular moment. The *motor schemas* by which we mimic the action taking place on the screen seem to provoke some movements and inhibit others at the incipient stage. The cumulative and uneven way in which this takes place while the film is being shown poses a problem which is not without importance.

We can foresee now all the vistas that are opened up to psycho-physiological analysis, and the few facts which we have given prepare us for the work of Professor Michotte and the consideration of the phenomena to be taken up in the third part of this study.

More recent research, using Rorschach tests together with EEG recordings, have clarified our understanding and made it possible to

go more deeply into the study of the phenomena of perception (55). In studying the relationships between electro-encephalographic reaction to movement and the number of kinaesthetic responses, we observe that individuals who have many kinaesthetic responses are more apt to be found in the electro-encephalographic group which has no reaction to movement. This fact may be compared to certain observations made by G. Heuyer and his collaborators during their work with backward children (108). Tracings made of 40 individuals while watching a film showed that the electro-encephalographic phenomenon of reaction to movement was less frequent in the backward child (approximately 1 out of 5) than in the normal adult (approximately 1 out of 2). Experiments show, however, that kinaesthetic reactions are particularly numerous in the backward child. This fact would seem to confirm the existence of an inverse relationship between kinaesthetic reactions in the adult and their electro-encephalographic reaction to movement—that is, between the image of movement and the beginning of real movement objectified by the EEG when the film is projected. This observation is worth noting because a similar problem arises with regard to visual images compared to the phenomenon of real vision. According to Grey Walter, the different types of traces are related to the type of visual imagery. In studying the responses of individuals to a very simple problem in geometry posed verbally, this author notes that some of them 'see' the elements of the problem with their shapes, angles, and even colours, whereas others solve the problem by reason alone. These different types of visual imagery have different types of EEG traces. More recently, in a further study using frequency analysis, Grey Walter succeeded in objectifying certain elements by which he was able to separate the mechanisms responsible for *visual reality* from those responsible for *visual representation*.

It is possible that in like manner a more thorough EEG study would make it possible to differentiate between the mechanisms responsible for the functional reality of movement and those responsible for the representation of movement which are especially produced in kinaesthetic reactions (traces only slightly modified by film movement). These ideas form an excellent background for the work in experimental psychology which we are now about to consider.

EYE MOVEMENTS

Going into further detail, we might mention a certain number of precise facts and experiments in connection with movements of the eye during visual perception. The work of Enoch (64) and Ford, White, and Lichtenstein (75) has shown that there are patterns in the free exploration of a field, and varying densities of visual fixations in a given area of search (see illustrations). From another point of view, Fraise and Battro (77) have studied the way in which the number of eye movements and the field of search vary during tachystoscopic presentations lasting from one one-hundredth of a second to a few seconds. It is interesting to note with the authors that, in applying these results to the cinematographic situation,

... we find that the ability to apprehend increases rapidly for short exposure periods of less than 20 or 30 hundredths of a second which do not leave time for visual search, or at most allow only a short movement. . . . Between 30 hundredths of a second and two seconds, on the contrary, perceptual activity and visual activity intervene and slightly increase the ability to apprehend. . . . For longer periods of six to ten seconds the subject's responses again begin to increase slightly, this progress being due no doubt to a memorizing activity.

These results enable us to make a preliminary interpretation of the facts observed by Mira y López. The number of movements increases in relatively long presentations, thus introducing the factor of the rapidity of eyeball movements into the phenomenon of perception. An individual with a slow motor reaction will have a slower exploration speed and a bradypsychic individual will make a lower average number of searching movements in a given time than a normal individual. Perceptual activity will thus be lower, and such individuals will not see as much as their companions in identical positions.

Less scientifically, but of more importance to the educator, we must consider the matter of motor dissymmetry in the searching movements of the eye on the screen; in more simple terms, we must determine whether individuals are right- or left-eyed. We now know that all our motor activity is not strictly symmetrical, and that as a result of the dominance of one of the cerebral hemispheres over the other, we are usually one-sided. This means that in vision the eyes do not play exactly the same part. It is quite easy to determine which is the dominant eye in any individual (*cf.*, for example, Zazzo, 233). We may also note that ocular dominance is a very complex phenomenon which is brought about by constitutional factors

as well as environmental and learning factors. Though many peoples in the world consider the right to be superior to the left because reading goes from left to right, half the population of the world or more reads from right to left or from top to bottom. We are, therefore, not attempting to establish absolute rules, but to draw conclusions from the fact that ocular dominance does exist. Let us imagine a left-eyed person. This means that the part of the screen to the left of the median axis will be better explored, better apprehended, better perceived, than the right half, assuming obviously that all other things remain equal—that is, that the density of information on the left side of the screen is identical with that on the right half and that the affective potential of the two halves of the screen are comparable. (In order to eliminate the inevitable inequalities, this problem would have to be studied statistically.) It is clear that the farther a left-eyed person is seated to the left of the screen, the less chance he has of perceiving the entire screen correctly because the right-hand part of the screen, which is farther from his eyes than the left-hand part, will be less well explored. Before making any scientific experiment with or educational use of projected material, individuals should be seated in relation to the screen according to their vision, lest this factor constitute too serious a variable in the total situation.

The external conditions of perception should always be stated very carefully because perception reactions may vary, as is shown from the results obtained by Mme Leboutet in a study analysing the mode of perception of an image according to whether it was presented on a screen or by some other device.

IMAGE PERCEPTION AND SITUATION

We are taking large extracts from the work of L. Leboutet (130) because it was carried out in a scientific manner and constitutes a good example of an experimental plan organized so as to ensure that the results obtained could be correctly interpreted.

The main object of these experiments was to compare the perception of still pictures (photographs) viewed close up and pictures projected on to a screen. This research was carried out on French pupils between the ages of nine and thirteen.

The first experiment was made with children of ten to twelve. Thirty-two girls and thirty-two boys were divided into two groups, each with 16 boys and 16 girls, according to the acuteness of their vision. Group A was first given eight pictures to examine while

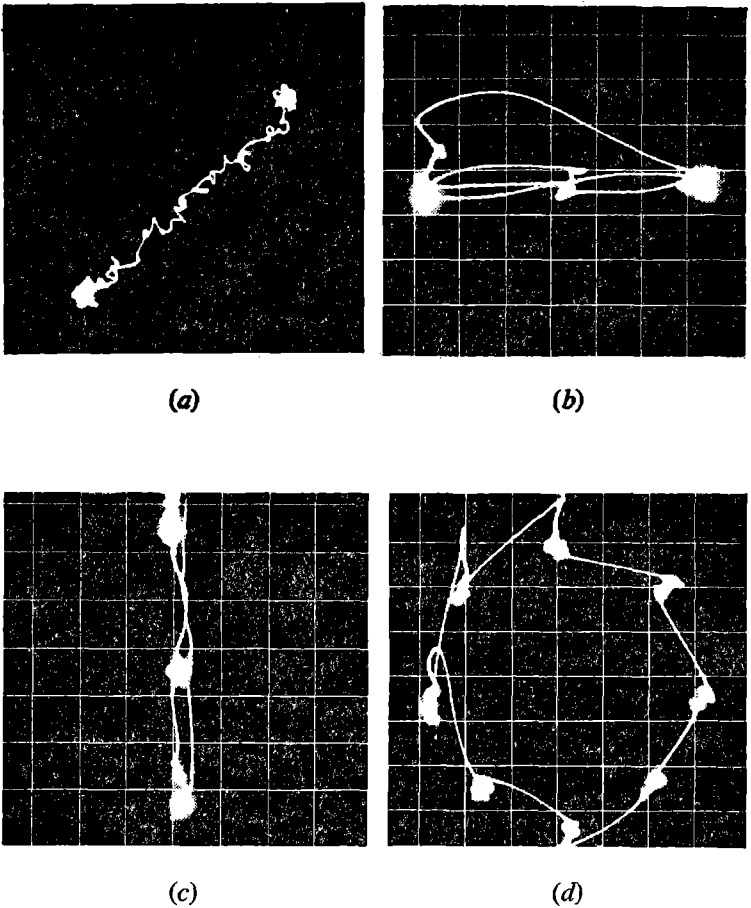

FIG. 6. CALIBRATION PLOTS FROM THE CRO

(a) A change of 10 v for an artificial signal, Y plotted on X , where $Y = X$. The irregularities are from electronic noise and have an amplitude less than $1\mu\text{v}$. (b) Eye movements alternating between 2 dots 30° apart, and then back to centre, in the horizontal direction. (c) Alternation for the same amount in the vertical direction. (d) Eye fixations on eight equally spaced dots around the rim of the circular field of search with a diameter requiring a total of 30° of eyeball rotation.

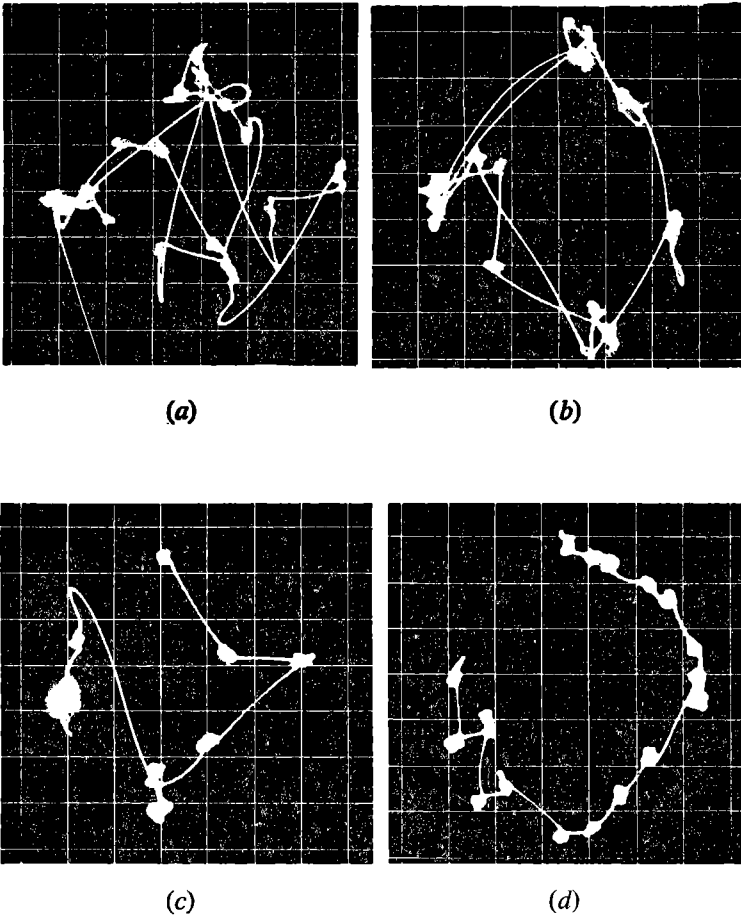

FIG. 7. PATTERNS OF EYE MOVEMENT ON A CIRCULAR FIELD WITH A DIAMETER SUCH THAT THE EYEBALL ROTATES 30° IN CROSSING FROM ONE SIDE TO THE OTHER

(a) The subject searched for the target in large, random, saccadic jumps between fixations. (b) The subject changed his method of search to a circular path around the margin of the field. (c) After 7 fixations the target is discovered and fixated. (d) The subject again changed his search method to short saccadic jumps, but he failed to complete the marginal search in the limit of 5 sec., so part of the field seems to have been unexplored.

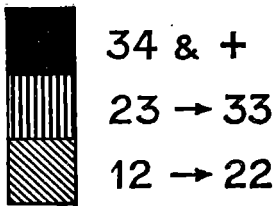
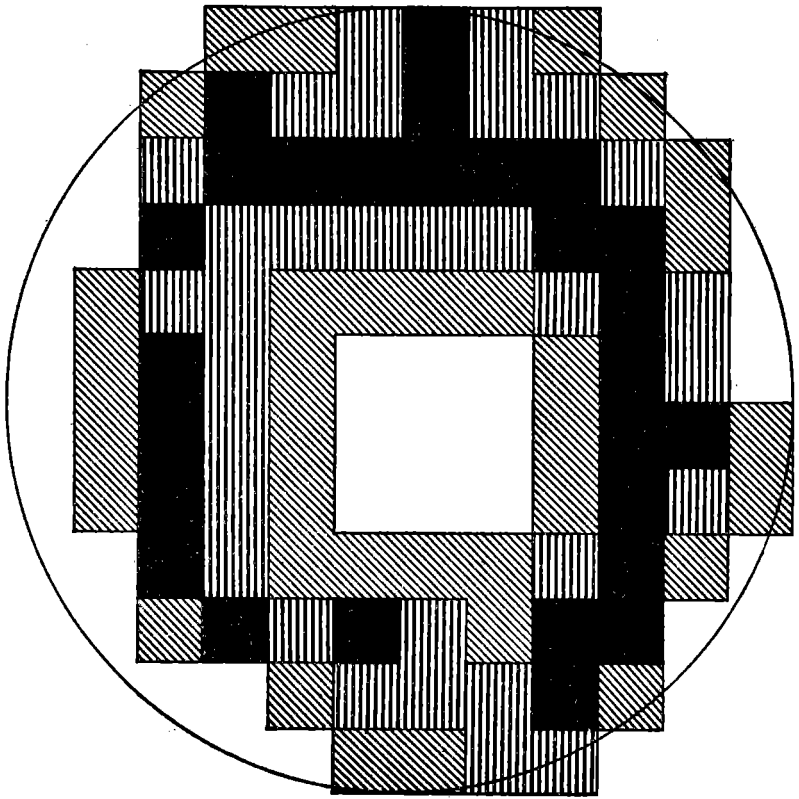

FIG. 8. DENSITY OF FIXATIONS PLOTTED IN CELLS OVER THE CIRCLE OF RESEARCH TO SHOW REGIONS OF CONCENTRATION AND NEGLECT

Group B was shown eight different pictures by projection; then the situations were reversed. Thus each pupil saw each picture only once, but he saw all the pictures either in photograph form or projected on to a screen as shown in the following experimental plan:

TABLE 1. EXPERIMENTAL PLAN

	<i>Pictures</i>	<i>Projections</i>
1st session	Group A	Group B
	Pictures 1 to 8	Pictures 1 to 8
2nd session	Group B	Group A
	Pictures 9 to 16	Pictures 9 to 16

The pictures selected were photographs of landscapes or scenes familiar to the children; every effort had been made to obtain reproductions that were as technically perfect as possible.

At the beginning of each session the instructions given to the children were as follows: "Write on the sheet of paper that has been given to you everything you see in the picture." They were promised an entertainment film at the end of the experiment and were forbidden to talk. The following paragraphs concerning the examination and analysis of the results obtained are taken from Mme Leboutet's report:

(a) *Analysis of results*

The working instructions given to the children encouraged them to list details such as a street, trees, grass, a church, etc. We have studied the pattern of these details using Rorschach's classification in order to compare our results with those of Dworestky in his study on perception. Sometimes these details were characterized by adjectives such as large, small, old, young, and this occurred more frequently with the photographs than with the projections. Verbs were occasionally applied to objects—for example, ladders going up, cables coming down.

We observed a certain number of verbal stereotypes already noted by Moritz and Monchamp in their studies on images. A tower becomes "the Eiffel Tower", a factory "the Renault Factory", trees become "green trees", etc. We might note also that colour seems to be seen by certain children even in black and white pictures.

The difficulty of this type of inventory came mainly from the use of words which were beyond the average vocabulary of the

76 *Basic Phenomena of Perception*

children involved in the experiment. These words presupposed the overall recognition of things from a few characteristic elements which were not yet rooted in the child's thought (*e.g.*, woodyard, garage, factory, dock, etc.).

(b) *Quantitative analysis of results*

We made out a card for each picture on which we noted the series of details which had been seen, identified, and named, numbering them in their order of appearance. The replies are tabulated below.

Let us take as an example a slide showing a river with rocky islands covered with trees, a house on one of the islands, a few bathers, and some small boats.

EXAMPLE: SLIDE NO. 7, PROJECTION, BOYS

PUPILS' NAMES	DETAILS						NUMBER OF REPLIES PER PUPIL	
	Water	Houses	Trees	Bathers	Boats		
A	2	1		4	3	5	
B	1	3	2	5	4	7	
C	2		1	3		8	
D	2		1	3			
.								
.								
.								
.								
P	1	2	4	3	5	10	
NUMBER OF REPLIES PER DETAIL		12	7	5	13	6	49

The total number of lines having figures in each column represents the number of pupils who observed that particular detail.

The largest number in a given row represents the number of details observed by a pupil for a given slide. This number appears in the last column.

For the two series of eight pictures examined by both girls and boys, by direct vision or by projection, we tabulated approximately 7000 details.

COMPARISON OF THE NUMBER OF DETAILS OBSERVED FROM PICTURES AND SLIDES (BOYS)

Boys	PICTURES			PROJECTIONS		
	Number of Pupils	Number of Details	Average per Pupil	Number of Pupils	Number of Details	Average per Pupil
Series 1	16	924	57	12	611	50
Series 2	13	688	53	16	675	42
Total		1612			1286	

COMPARISON OF THE NUMBER OF DETAILS OBSERVED FROM PICTURES AND SLIDES (GIRLS)

GIRLS	PICTURES			PROJECTIONS		
	Number of Pupils	Number of Details	Average per Pupil	Number of Pupils	Number of Details	Average per Pupil
Series 1	16	1379	86	16	878	54
Series 2	13	1160	72	16	719	45
Total		2539			1597	

An analysis of these figures shows that:

- (a) In all cases the children observed more details from direct examination of a photograph than from projection on a screen.
- (b) Girls noted more details than boys.

We shall proceed now to carry out an Analysis of Variance of the number of details in order to study the effects of:

1. Difference in the mode of presentation—photograph or projected slide.
2. Difference in sex of observers.
3. Difference in picture content.

We shall also study the first order interactions of these factors. One of the groups of boys numbered only 12 pupils; we have, therefore, reduced the number of pupils in each group to twelve by eliminating pupils at random from the larger groups.

ANALYSIS OF VARIANCE

SOURCE OF VARIANCE	NUMBER OF DEGREES OF FREEDOM	SUM OF SQUARES	AVERAGE SQUARE	F	0.01
Mode of presentation	1	846	846	284	Significant
Sex	1	355	355	119.5	Significant
Picture content	15	758	50.5	17	Significant
Interactions:					
Sex × mode	1	176	176	59.3	Significant
Sex × picture	15	47	3	1	Not Significant
Mode × picture	15	857	51.1	19.2	Significant
Intra-group variance	719	2139	2.97		
Total variance	767	5178			

1. This table shows that the three factors mentioned above cause quite significant differences. The mode of presentation has a preponderant influence and shows us that the perception of an image on the screen differs from the perception of the same image viewed close at hand. In our experiment the factors of sex and image content also played a strong rôle, and it will be necessary to make a systematic study of their effects.

2. We observe likewise that there is an interaction between sex and mode of presentation and between mode of presentation and image content, but there is no interaction between sex and content.

The following conclusion can be drawn:

Under the conditions of our experiment, children observe more details from the study of photographs than from the study of slide projections.

	PHOTOGRAPHS	PROJECTIONS
Boys		
Series 1	14.93	10
Series 2	10.58	7.41
Girls		
Series 1	15.87	11
Series 2	14.59	8.77

Furthermore, inspection of the frequency distributions showed us that dispersion was greater in the case of photographs. A comparison of the appropriate statistics confirms this.

We may say, therefore, that responses on the whole tend to be more unified with projected images than with photographs ex-

amined at close range, and the children's attention is also concentrated more on the same details.

The location on the picture of the first detail noticed by all the pupils can be plotted. We then obtained charts such as the following, selected at random:

Example: View 1, Girls

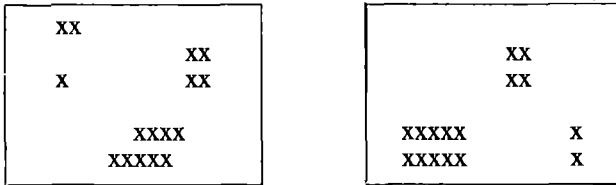

We shall not give all the details of this part of the study because we have been unable to illustrate this article with reproductions of the pictures used, but we noted that on the whole the density of points was greater for slide projections.

The educational consequences of these observations are obvious, but further study would be necessary to show that the areas of possible use for slide projections would not be exactly the same as for pictures meant to be seen at close range.

The full interpretation of all these results raises a number of difficulties, however, because the conditions of perception are not identical, and the influence of image luminance might well constitute an important differentiating factor. (Piéron and his colleagues, in their *Vocabulaire de la Psychologie*, have defined luminance as the variation of the intensity of a light stimulus which produces a sensation of brightness. Photometric brightness differs from retinal illuminance only in a purely ocular factor.) In a new experiment using special devices, the author studies the perception of images in three different situations:

- (a) Episcopic projections on a screen, with the children all being seated properly in relation to the screen in order to eliminate any factor of directional reflection.
- (b) Presentation of images in a dark box in order to eliminate the influence of the lateral field of vision.
- (c) Presentation of images under conditions of normal vision.

In all three cases the luminance is kept constant in order to eliminate this factor of differentiation.

We shall take from this experiment only the results which are of

80 *Basic Phenomena of Perception*

educational and psychological interest. Under these special conditions of equal luminance in all cases, the differences in the number of details observed are no longer significant; what is being studied here are the laws of visual perception in relation to the intensity of the stimulus. But it is interesting to note another factor, as the author does: having observed a constant decrease in the number of observations from the beginning of the test to the end, we tried to show by factorial analysis that this was due to a factor of fatigue rather than to any other conditions of the examination. The results are as follows:

TABLE 2. TOTAL NUMBER OF DETAILS OBSERVED

GROUPS	1ST TEST	2ND TEST	3RD TEST
e_1	521	466	367
e_2	506	483	349
e_3	535	450	444
Total	1562	1399	1160

An analysis of these figures reveals a specific factor of fatigue which increases as the experiment continues.

This brings us back to our educational considerations. The teacher should always try to secure the best conditions of presentation so that perception will be at its highest, and he should take into consideration the length of time that it lasts so that fatigue will not reduce the effectiveness of the modern techniques being used.

THE IMPORTANCE OF SIZE

The study of different perceptual situations, as we have just seen, shows that there are differences which must be taken into consideration either when these techniques are used or when experimental results are being interpreted. Among the variable factors, special mention must be made of the size of the picture. In most cases projecting a picture on to a screen produces linear changes, the effect of which must be studied in order to analyse the phenomena of perception more accurately. We refer in this regard to the excellent work of Osterrieth in his test which involves copying a complex figure (169). The author asks the subjects being tested to reproduce the following figure, under certain specific conditions which we shall not go into here:

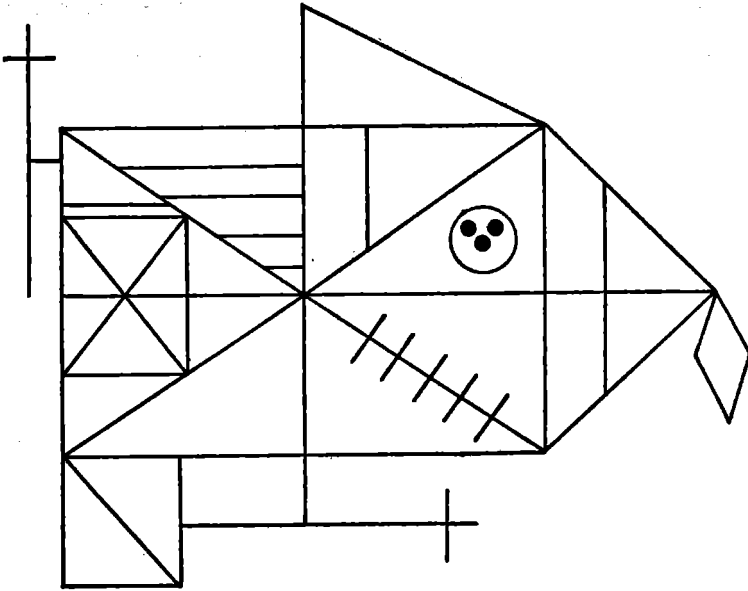

FIG. 9. COMPLEX FIGURE (OSTERRIETH TEST) WHICH VARIOUS SUBJECTS OF DIFFERENT AGE GROUPS WERE ASKED TO ANALYSE

Qualitative analysis of the reproduction and the mark given to it bring out certain perception phenomena and types of reproduction which vary with three distinct age groups:

Very young children (averaging four years of age) usually make a chaotic reproduction in which, however, a few elements are, recognizable. The next stage is one in which the reproduction is made by juxtaposing small portions of the figure (five to twelve years). The final stage is one in which the subjects usually begin with the central rectangle and arrange the other elements around it (eleven years and above).

In discussing these results and trying to explain the reason for the spottiness frequently observed at the second stage, Osterrieth systematically studied all the factors at work and wondered why the rectangle which forms the underlying structure of the whole figure was not correctly reproduced by the young children. He says:

We were struck by the fact that certain elements, especially the 'large rectangle' which is the underlying structure of the drawing, never appear as such in copies made by younger children, and we wondered whether or not the children 'saw' these elements in

82 *Basic Phenomena of Perception*

the model. It was not difficult to reproduce these elements on separate cards following the exact scale and orientation of the original, and to ask the children whether or not these elements were to be found in the figure.

The extremely important results of this research may be directly applied to the audio-visual situation to explain some of the difficulties pointed out by several authors concerning the difficulty of comprehending pictures projected on a screen.

TABLE 3. OBSERVATION OF DETAILS IN THE ORIGINAL MODEL, WITH PERCENTAGES OF DIFFERENT TYPES OF ANSWERS

AGE	CORRECT ANSWER IN LESS THAN 30 SECONDS	SIMILAR DETAIL NOT IDENTIFIED	FANCIFUL ANSWER	NEGATIVE
years	per cent	per cent	per cent	per cent
5	50	7	14.5	28.5
6	53	3.5	11.5	32
7	61.5	5.5	11	22
8	71.5	5.5	3	20
9	86.5	3.5	1	9
10	89.5	1.5	2.5	6.5
11	93.5	1.5	2	3

The author concludes:

1. Between 5 and 11 years of age the number of details observed correctly gradually moves up from half to almost the entire number; the most noteworthy increase takes place between 8 and 9 years of age.

2. Details are not recognized or are declared absent by over 25 per cent of the children under 7 years of age. This percentage gradually decreases to less than 10 per cent at the age of 9 and 5 per cent at 11. The largest reduction takes place between the ages of 8 and 9.

3. Precision of observation increases with age: the number of similar but not identical details as well as completely different details wrongly observed diminishes markedly, going from 21.5 per cent at the age of 5 to 3.5 per cent at the age of 11.

The results are disturbing, in a sense, because they show the difficulties that infant-school children have in perceiving correctly the pictures which they are shown. The problem then arose of explaining these difficulties, and, to complete his analysis, Osterrieth classified the different details of the diagram in several categories; a large difference was evident between the percentages of correct

answers obtained for a particular age. For example, for five-year-old children the three categories in which details were classified yielded 'correct' percentages of 98 per cent, 37 per cent, and 28 per cent. A close analysis by the author of the percentages obtained enabled him to reach the following conclusions which we give in summary form:

1. Small characteristic details which stand out from the rest because of their form or position and which are units in themselves are easily noticed at every age (*cf.*, what was said above about 'form' and 'structure').

2. Observation of more complicated details requiring a higher degree of perceptive activity is rarely accurate before the age of 7.

3. Larger details, being different from the previous ones because of their symmetry, regularity, and larger dimensions, pose a problem of importance to our study. They are obvious to adults, they are less easily discerned by children under 7. It would seem that the 'size of the figure' is a factor which introduces a particular difficulty. Various authors have pointed out how important closeness is in the child's perception. Piaget in his work on perception (174) demonstrated the rôle of decentring the gaze in order to regulate the centring action which always has a distorting effect. According to him, adult perception is more objective than that of the small child because of the action in time required by the different successive centring. The inability of young children to see the 'large details' might be explained by the need to co-ordinate a very large number of successive centring; and here again, by a different path, we come upon the problem of the speed of the mental processes which we have already considered.

Whatever the full interpretation of these difficulties may be, the author concludes as follows:

The large details of the underlying structure are apparently not perceived before the age of 7 because of their large size, which makes them more difficult to detect than smaller details even if the latter are more complicated. After the age of 7 the factor of complication (or the perceptive operation involved) becomes more difficult than size.

Thus the laws of perception are not laws of 'geometrical similarity'. The same figure shown to children in different ways does not produce the same psychological reactions. The same film seen on different screens arouses different impressions. The constant attempt to increase the size of the projection surface has met with serious

84 *Basic Phenomena of Perception*

problems. In striving to create a greater impression of reality, exaggerated close-ups, which by their very size go contrary to correct perceptive interpretation, sometimes do just the opposite.

This last remark introduces a new problem which we cannot avoid in a study on visual perception and which we shall have occasion to come upon again in connection with cinematographic comprehension—namely, that of the changes in scale from one frame to another. In editing a film, scenes taken from different angles and different distances are mixed together, and the whole art of the cinema requires the constant use of this change back and forth, without which a film would seem monotonous. The diagrams below show the three main types of shot.

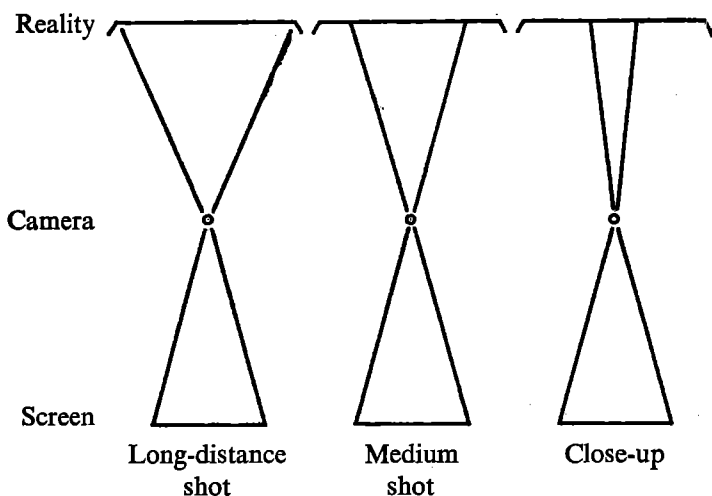

FIG. 10. VISUAL PERCEPTION AND THE USE OF DIFFERENT PLANES

The spectator's angle of vision remains the same because his distance from the screen is constant throughout the projection. But the scale of what is seen from this angle varies continually. The nose of an actor, which is only a tiny spot of shadow in a panoramic shot, takes on a certain dimension in a medium shot and becomes enormous in close-ups; a microbe which is only a few microns long seems like a monster on the screen. These variations in size certainly give rise to problems that have not yet been thoroughly studied. At the simple perceptual level, what happens to visual accommodation

while these changes from far-away to close-up shots are taking place? What effect does it have on the perception of a third dimension? Assuming that these facts have their physiological counterparts, do they contribute to, or take from, the final interpretation which is to give the message its true meaning? Later on it will be seen how they can be approached using film material especially designed for this purpose (161).

The problem of size in the audio-visual situation is of great importance in the early years of primary school. The adult later accommodates easily to the inherent difficulties of perception from a screen, but this is not true for the child, and the teacher should never forget that a child's vision is not exactly the same as his own. Thus a special preparation or mode of presentation is required for educational purposes in order to counteract the distortions of perception and the false perceptions which lead to errors of comprehension.

PERCEPTION AND THE POSITION OF THE CAMERA

We have insisted on the duty of the act of perception and have tried to show that it cannot be separated from the other elements of the visual situation. For this reason we should like to say a few words on the importance of photography on perception—that is, on the ease or difficulty with which messages are received. Let us recall in this respect that the camera may either be situated outside the scene being filmed or else be inside the situation in the place of one of the dramatic characters in such a way as to show the view that he himself would have of the scene. This is called the subjective camera. This simple distinction is essential in education. A pupil or soldier in the army is shown how a movement should be performed by having it demonstrated before him, but it is impossible for him to see the movement from his own point of view. Experiments have been made in connection with the learning of a movement that is peculiar to a given trade (167):

When a worker is to be shown how to carry out a particular piece of work, the camera may photograph the movement from two opposing angles: the scene may be shot from the point of view of the worker who is performing the task properly (subjective camera), or on the contrary from the point of view of the apprentice who is watching the worker at his work (objective camera). Studies carried out using two such different films of the same subject show that results are better when the scene is filmed

from the point of view of the worker actually performing the movement (subjective camera). The spectator is given the impression of taking part in the movement himself, and when he later tries to perform it he will have no trouble in restructuring the space in which he operates. This makes it all the easier to acquire that precise knowledge which is necessary in learning to perform specific professional movements.

Despite these important results, which are especially valid for adolescents and adults, one can hardly fail to compare them to the problems considered by Piaget and Inhelder with regard to the child's concept of space (173). The child cannot orient himself readily in a landscape, and, because of the difficulties he has in de-centring himself, he finds it hard to adopt the point of view of others. The authors quoted above have analysed in great detail how the representation of space is developed and built up in the child, and they have pointed out all the difficulties he encounters. They did not use cinematographic techniques in their experiments, but their methods and results might be copied and applied to experiments using films.

The importance of the position of the camera in taking the picture would make it possible to draw up further conclusions from the experiments reported on by Piaget and Inhelder in the last chapter of their book, where they study how a human figure is located in a landscape and how the layout of a village is grasped. The study of the way in which different perspectives are made to relate to one another (Chapter VIII) is likewise directly related to our subject. It will suffice to describe the conditions under which the experiments were carried out to give an idea of their importance. Let us turn to the words of the authors:

We used a model made of papier mâché 1 m. square at its base, showing three mountains 12 to 30 cm. high. From his normal position before the model (position A) the child sees in the foreground, slightly to the right, a green mountain with a small house on top of it, and to the left an earth-coloured mountain a bit farther back, somewhat higher than the green one and recognizable apart from its colour by a red cross at its peak. The highest of the three mountains rises in the background as a grey pyramid, its peak covered with snow. From position C, opposite to A, a zigzagging road can be seen on the side of the green mountain. From position B a small stream can be seen flowing down the earth-coloured mountain. Each mountain has a single colour, with the exception of the white at the top of the grey mountain, and the only landmarks are those which we have just described.

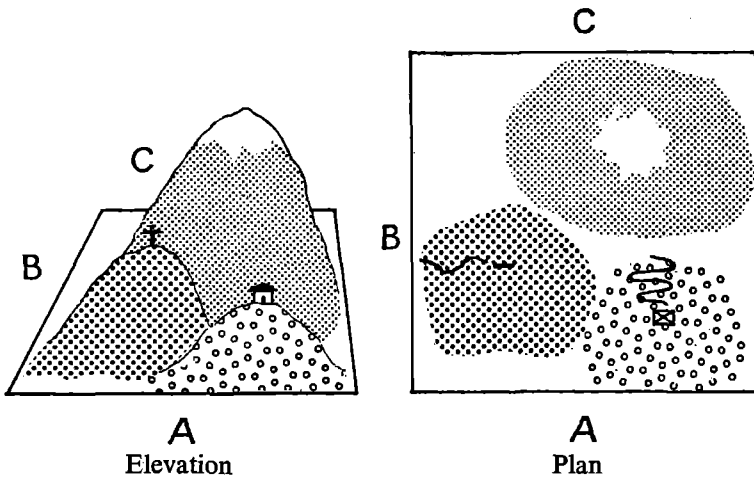

FIG. 11. THE INFLUENCE OF VIEWPOINT ON PERCEPTION

We presented to the subjects being tested ten different pictures measuring 20 cm. by 28, showing the same mountains seen from different points of view, in an easily recognizable form and sufficiently large so that the outstanding signs (cross, house, white peak, etc.) were clearly visible, and the colours the same as those of the model. We also had three moveable cardboard mountains modelled and coloured the same way as those of the original. These mountains could be moved about by the child in such a way that he might reconstruct the landscape from any particular angle. Lastly, the materials used included a wooden doll 2 to 3 cm. high, the head of which was simply a round knob without any face, so that the child would not have to take into consideration the direction of the gaze and could concentrate on the location of the figurine. This doll was placed successively in different spots, and the problem consisted in finding the relationship between its different locations and the possible views it had of the three mountains. Thus it was not the child himself who walked around the mountains—except when he was allowed to verify his replies—but rather the doll which did the travelling, and the child had to imagine and reconstruct by inference the changes in viewpoint that went with these shifts in position, or else the changes in the position of the figure as the landscape changed.

We can see immediately the analogy that might be made with the picture, either still or moving, recorded by a camera that can be moved anywhere in relation to the landscape or the scene. If we try to sum up the excellent analyses of the authors we might say that there are three main stages in psychological development. In

the first stage the child is unable to answer elementary questions. The second stage (up to the age of 7 or 8) is characterized by "a complete or partial non-differentiation between the point of view of the subject and that of other observers"; all the replies show that

the child in fact expresses his own point of view, as though the mountains could not be seen from any point of view except his own. Stage III (from the age of 7 or 8 to 11 or 12), on the contrary, is marked by differentiation and the growing co-ordination of different points of view. At level III A (from 7 or 8 to 9, on the average), there is differentiation of certain relationships according to the changes in the observer's position, but there is still no overall co-ordination of points of view. This is acquired towards the age of 9 or 10 at level III B—that is, at the age where, as we have seen, simple types of perspective are finally grasped and perspective makes its appearance in drawing (visual realism).

When the camera, either successively or simultaneously (montage effects), photographs from different positions in space, the visual message does not have the coherence of direct visual impressions, and in order to be perceived correctly it must be aided by perception and intelligent activity which is impossible before a certain age.

PERCEPTION OF MOVEMENT

1. Either the camera remains fixed, as the eye of the spectator would be in watching everything going on around it, and the filmed picture reproduces approximately what would be perceived directly from reality.
2. Or the camera itself moves and the spectator identifies with it. In this case the whole landscape and persons in it pass across the screen. People who are not accustomed to cinematographic vision react strangely to this: spectators have been known to run away screaming with fear because, as they said, the houses began to move. This reaction shows that without a certain habit—which in this case means a basic familiarity with the cinema—individuals do not always initially interpret correctly messages shown on the screen. In certain intermediate cases the camera moves at the same time as the person on the screen, and the latter then appears motionless, whereas the scenery moves in an opposite direction. There is also the so-called subjective camera which moves as the observer's eye would move and which tries to take into account the personal aspect of vision.

3. Or else movement is suggested by several scenes which follow one another in time, with or without connecting fades. In this case the spectator must reconstruct movement with the visual signs put before him. This implies a psychological activity operating both upon space and time, and not every spectator is capable of this. We shall return to these problems when we come to study comprehension at the cinema.

Psychologists have not studied all of these situations in detail, but some specific research has been done on certain limited aspects of the problem by Professor Rey (187). His work is of great interest because it shows one of the ways in which these questions may be approached experimentally.

Rey first constructed a very simple device in which marbles could be moved in directions shown by the arrows on the diagram.

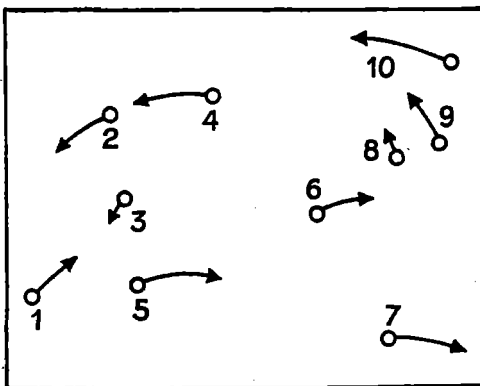

FIG. 12. VARIOUS TYPES OF PERCEPTION OF MOVEMENT AND DIRECTION

The results of the experiment are of interest because they reveal the variety of effects possible. Various types of perception were identified and catalogued as follows:

- (a) Rotation of the marbles through an angle of approximately 90 degrees, about the middle of the rectangular field, the motion being in a counter-clockwise direction. Under this aspect all the individual movements are part of the general effect, and many errors of observation are made.

90 *Basic Phenomena of Perception*

- (b) Same overall effect, but with an impression of movement towards the centre.
- (c) Same basic overall effect, but with one or two marbles moving separately and even in an opposite direction: marble 1 moves upward in a straight line while all the other points turn about the centre of the field in a counter-clockwise direction; marbles 1, 4, and 7 become detached from this general movement and drop towards the bottom.
- (d) Two movements, turning in opposite directions, begin in the lower central part of the field and meet in the upper central part.
- (e) Two rotation movements take place on opposite sides of a line with marbles 5, 6, and 7 remaining motionless.
- (f) Slight overall movement on the right side of the field; the marbles on the left side remain motionless.
- (g) Two distinct turning movements on either side of the field, each movement having the characteristics described under (a) above.
- (h) Right and left halves of the field converge towards the centre.
- (i) Horizontal shift from right to left of all the marbles in the upper half of the field, while those in the lower half remain motionless.

A very large number of individuals did not perceive all the movements correctly. In the face of so many mistakes and finding that adults were incapable of answering correctly, Rey then constructed a simpler device which made it possible to obtain a clearer idea of the difficulties introduced. In this device simultaneous horizontal movements could be produced from left to right or vice versa, varying in number from one to five at a time. Thus it was easy to estimate quantitatively the exactness of replies given, and the following tables will enable us to draw useful conclusions from these results:

TABLE 4

.	→	→	→	→	→	.	←	.	←	←
.	.	.	→	.	.	→	→	→	→	←
.	→	→	.	→	.	←	.	→	←	→
→	.	→	→	→	←	.	→	←	→	→
.	.	.	→	→	→	.	→	→	.	→
1	2	3	4	5	6	7	8	9	10	11

TABLE 5

Ages		1	2	3	4	5	6
4½ to 5½ years	1	50	50	35	22	22	5
	2	72	35	35	22	22	0
5½ to 6 years	1	60	50	35	15	20	15
	2	85	60	65	35	30	30
6 to 6½ years	1	90	75	60	40	25	25
	2	90	100	75	55	55	30
6½ to 7 years	1	75	70	55	55	75	40
	2	90	75	75	70	85	70

The above table is an extract taken from the general results. It gives the number of correct replies by individuals in two successive tests with arrangements as numbered.

What do these numerical results teach us and how are they related to our educational and psychological considerations? First of all, we note that from the age of 6 onward, results improve with the second trial on all the arrangements; between 5 and 5½ years this progress is observable only with the simplest arrangements. We also observe, Rey notes, that it is worth showing a film a second time to children over 6 in order to obtain a greater effectiveness.

On the other hand, for every age the percentage of correct replies concerned only with position is much greater than the percentage of successful replies in which the direction of movements is also included. The author concludes:

The perception of motion is thus dissociated to a certain extent from the perception of spatial direction, whereas it might have been assumed that to perceive a movement is necessarily to observe its direction. . . . We may thus presume that there is a kind of primary cinematic perception which does no more than observe the spots where movements are produced. Observation of their direction would seem to be a secondary, more complex phenomenon involving spatial co-ordinates and a detection of movements in relation to one another.

In order to explain all the results which he analyses in his book—and which we must omit here for lack of space—Rey refers to motor phenomena, to the difficulties of the child in this matter, and to the time required for the different ‘centrings’ which are necessary.

92 *Basic Phenomena of Perception*

Rather than limit himself to movements which were too mathematical and artificial, the author completed his first studies by using puppets to which five different movements could be imparted simultaneously; the children then had to imitate these movements with a similar puppet which they were given. This test, given both to adults and to 20 children, 6 to 7 years of age, in Geneva, yielded the following results:

TABLE 6

Adults:	
Reproduced the 5 movements exactly	{ Trial 1 . . . 5 per cent Trial 2 . . . 10 per cent
4 exact movements out of a possible 5	{ Trial 1 . . . 35 per cent Trial 2 . . . 45 per cent
Children from 6 to 7 years of age:	
Reproduced 5 movements exactly	{ Trial 1 . . . 0 per cent Trial 2 . . . 0 per cent
4 exact movements out of a possible 5	{ Trial 1 . . . 0 per cent Trial 2 . . . 0 per cent

These results are somewhat discouraging. If we now consider the total number of movements reproduced exactly, rather than the groups of 4 or 5 movements reproduced accurately, we then obtain a less negative table, but one which none the less causes the educational psychologist to reflect.

TABLE 7

	TOTAL NUMBER OF MOVEMENTS	NUMBER OF MOVEMENTS REPRODUCED EXACTLY	NUMBER OF MOVEMENTS FORGOTTEN	NUMBER OF WRONG MOVEMENTS
<i>Adults</i>				
Trial 1	87 per cent	70 per cent	13 per cent	17 per cent
Trial 2	88 per cent	73 per cent	12 per cent	15 per cent
<i>Children</i>				
Trial 1	54 per cent	29 per cent	46 per cent	25 per cent
Trial 2	59 per cent	39 per cent	41 per cent	20 per cent

Let us note, however, that slightly more than half of the real movements were observed, and that the number of errors was more than 20 per cent. Thus, we see, as the author states, that

certain rôles are reversed and a surprising importance may be attributed to a minor detail in the accounts that young children give of shows which they have seen. The subject may have observed a movement that is quite secondary to the film as a whole. For example, he may see an object falling to the ground during a fight. This detail may become the central point of the entire action, and the child will claim to have seen an object which knocked over three or four persons as it fell. The logic peculiar to the child scarcely introduces into his perceptions, and his later memory of them, corrective elements that would tend to ensure coherence and verisimilitude.

All the results show that there is continuous progress with age. A child may be sensitive to the general feeling of a cinematographic scene and be emotionally affected by the play without clearly perceiving its different movements. Before studying the intellectual problems involved in cinematographic comprehension, it is perhaps necessary to investigate certain primary processes which condition these problems.

At this point in our analysis we must move to another plane and adopt the approach taken by Michotte in his more recent studies (163). In a memorable lecture delivered at the Institut de Filmologie in Paris, Michotte, before going into the question of the spectator's emotional participation or empathy (see below), stated that "the study of the purely visual perception of movements and their combinations is apt to shed some light on the matter". Here are a few of the author's basic observations which enable him to make some penetrating analyses:

1. Whenever two or more objects move across a visual field at different speeds or in different directions, the movements and objects are seen as completely separate from each other.

2. When two or more objects present in a field of vision begin moving simultaneously at the same speed and in parallel directions, but at sufficient distances from one another, and particularly if they are moving in different frames of reference (settings), the objects and the movements which they execute are seen as separate. The coincidences of motion and time simply form an overall structural unity which is actually a parallelism between different events.

3. Assuming that the objects are closer together in space and that they are set in motion at the same velocity in parallel directions and in a common frame of reference, observers unanimously

state that they see a single movement executed by a group of objects.

This fact is extremely interesting because it shows that the difference in the paths followed (parallel but not identical) by the objects is not sufficient to ensure that each of them is considered exclusively responsible for its own motion. No object in such a case is perceived as moving by itself; the motion seems to belong to the group, and each object participates in the overall motion, or, in other words, there appears to be a single collective motion.

4. Lastly, whenever two objects some distance apart come together while moving at the same velocity, and continue to move together but in the same direction after meeting, they soon merge into a single overall object, provided their forms lend themselves to this fusion (two squares of different colours, for example), and are then seen simply as a complex object (two-coloured rectangle) with a motion of its own.

These experiments can be carried out with relatively simple techniques, going systematically and progressively from one result to the next on the strength of the well-known laws governing the structural organization of perception (proximity, similitude, common purpose, etc). We might add that similar tests can easily be carried out in the field of tactile-kinaesthetic perception of the movements of our limbs, and that they yield similar results.

The following conclusions may be drawn from these observations:

1. The physical motion of an object may be perceived as not belonging exclusively to it.
2. The separate motions of several objects may merge into a single overall motion which is attributed collectively to all the objects.
3. When juxtaposed objects move together in the same way they may be perceived as a single complex object.
4. It may be added that other experiments prove that the motion belonging to one object may in certain cases seem to belong to another object, as in the case of the perception of causality, for example.

It is clear that these observations are of great importance in interpreting phenomena of motor empathy. The differences between these phenomena and purely visual structures should, however, be stressed.

In the case of motor empathy, the movements executed by the actor-object are perceived visually, whereas those of the spectator-object are perceived in a purely tactile-kinaesthetic way. Normally,

the spectator does not look at his own limbs during a show. However, this only constitutes a minor difficulty, since it is obvious that the different ways in which the different senses grasp similar types of motion form no barrier to their fusion in perception.

There are, however, more serious objections.

The two objects, and consequently their movements, are usually separated by a considerable distance. Now, it is well known that distance is a powerful factor in segregation, and it might be found surprising that the movements of the spectator in the audience could become identified in perception with those of the actor on the screen. In this connection it must be noted that the influence of distance upon perception may be compensated to a large extent by the influence of other integrating factors such as continuity in time, a life situation similar to that of the actor, etc. 'Remote-control launching' is an excellent example of this type of perceptual integration despite the distance separating cause from effect.

For that matter, the distance may not be so great phenomenally, since in the cinema situation it is not a question of physical distance but of psychological distance, and this may be greatly reduced, particularly in cases where there is a 'visual contact' over an 'empty' space, without intervening objects, as in a darkened cinema. One has only to consider the immediate 'visual contact' established between two persons who are looking at each other, to realize that there is a real contact.

Thus it can be postulated that the movements of the spectator are apparently identified with those of the actor in virtue of the principles of similarity of underlying structure and recognition of a common situation. This explains why the spectator gets the impression "that he feels what the other person is doing".

We must refer also to a special phenomenon in connection with perception of a certain type of movement—namely, the stroboscopic effect. The stroboscope is an 'artifact' which is a product of technology. The study of a few particular situations will show us the difficulties of perception which the spectator encounters, and once again we shall find ourselves in the no-man's land between perception and intelligence.

The stroboscopic effect is caused by the fact that the motion-picture camera actually films a series of fixed slides (currently 24 per second for standard sound films). If the movement photographed is a cyclic one, curious situations may arise such as those explained by the following diagrams:

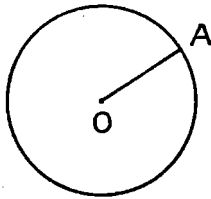
Example 1

The wheel and the spoke OA have a circular motion of 24 turns per second; each frame of the camera will photograph the wheel and the spoke in exactly the same position. When the film is projected the wheel and the spoke will appear motionless despite the rapid speed of rotation. The same illusion will be produced whenever the wheel turns at a velocity of $n \times 24$ turns per second.

Example 2. What happens when the wheel and the spoke OA rotate at a speed of 25 turns per second—that is, if it takes them $\frac{1}{25}$ of a second to complete a single turn?

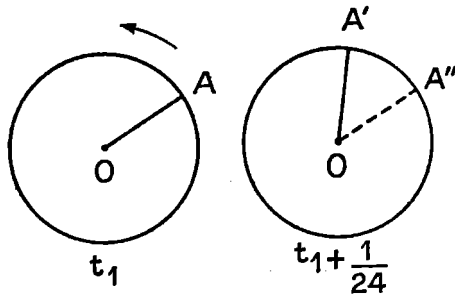

The first frame will photograph the spoke in the position OA at time t_1 ; by the time the next frame is photographed ($t_1 + \frac{1}{24}$) the spoke will have moved from position OA to OA' because it no longer requires $\frac{1}{24}$ of a second to make a complete revolution, but only $\frac{1}{25}$ of a second; at time $t_1 + \frac{1}{24}$ the spoke will have gone beyond its initial position, forming a small angle with it which is easily measured. The successive frames of the film will record a series of positions OA', OA'' . . . and reproduction on the screen will give the impression of an extremely slow movement. This is because between every two frames of the film the spoke turns through an angle of $\frac{2\pi}{24}$, and it will require 24 frames for it to return to its original

position. Thus the movement reproduced will be that of a spoke turning at the speed of one turn per second.

Example 3. If the wheel and the spoke turn at a rate of only 23 turns per second, the phenomenon is the same but in a reverse direction;

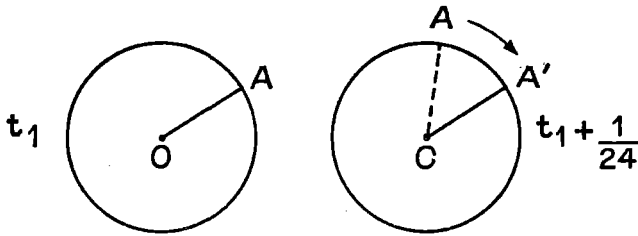

assuming that the first frame photographs the spoke in position OA (at time t_1), by time $t_1 + \frac{1}{24}$ the spoke will not have had time to make a complete turn, and as a result the wheel will appear to turn slowly backward when the film is projected on a screen.

Here we actually have two different phenomena of perception: the modification of motion and, in some cases, the reversal of the direction of motion. Motion is completely modified because what appears on the screen is not at all the result of accelerated or slow photography. Thus a new perceptual problem arises. In addition to the difficulties of perceiving motion which we have studied above, we now must take into consideration a contradiction between our experience of reality and the cinema image of it when we are shown a vehicle moving in one direction while its wheels seem to turn in the opposite direction.

In such cases the message perceived must be completely reconstructed by an intellectual effort, otherwise it will be completely distorted. We have had occasion to observe errors of interpretation of this type in cases where the face of a clock was photographed marking different hours. The film-maker meant to indicate that events were happening slowly in time or at regular intervals, whereas the child seeing the hands of the clock move more rapidly than usual concluded, on the contrary, that things were happening rapidly.

Thus, without any advance notice, the spectator is required to make two types of reconstruction of reality from what he sees on the screen. In one case it is the time-scale which he must alter in order to interpret the film correctly, and the psychological processes involved are probably similar to those which we referred to in

connection with changes in visual distance; the other case is much more complex and is hardly related to simple perception.

We must draw from all of this conclusions which are applicable to education. The effects mentioned above are of two types: the stroboscopic effect which is inherent in the cinema technique itself (except when it is deliberately created in analyses and scientific films), and slow-motion or accelerated effects which are introduced by the film-maker. This implies two types of problem for the educator who wishes to prepare his pupils and help them towards a better understanding of the cinema. The explanation of the stroboscopic phenomenon belongs to the field of science; but the explanation and use of the other effects belong primarily to the art of the cinema. In both cases adequate preparation is required, and since pupils cannot be given instruction of this nature before the relatively advanced age of 12 or 13, we must address an appeal to producers of films for children in the hope that they will use these effects sparingly, even though, we must admit, they have their place in the cinema and are tempting to film-makers.

IV. AUDITORY PERCEPTION

Of the two words 'audio-visual' often only the last is heeded. Many studies are devoted to the rôle of the eye, very few to the problems of the ear. While not wishing to deny the dominating importance of the visual over the auditory in audio-visual situations, there is something, nevertheless, to be said for trying to restore the balance a little in favour of the 'audio' aspect. It would be interesting to psychoanalyse research workers and attempt to find out the reasons for the relative poverty of studies on the auditory side despite the importance it should have both in ordinary life and in education. If Piéron is right in saying that "apart from detection and, to a minor degree, identification, auditory perceptions scarcely intervene at all in the two major domains of verbal communication and music", the emphasis must be placed on the adjective 'major', because the ear does help man to speak. It can be said, moreover—to keep to our own subject—that technological progress makes large demands on our auditory functions. There is now a telephone in every office, coupled with a system of inter-office communication; in the factory transmission is speeded up and simplified by small portable receivers through which liaison is maintained between fore-

men and managers; the gramophone-record industry has so developed in quality and quantity that the gramophone is becoming more and more an everyday object to children; tape-recorders of every kind are invading our daily life, and soon, instead of a letter several pages long, a small reel will be sent through the post. If this were not enough, mention could certainly be made of the transistors which have brought radio out of doors—very often at the expense of the calm and tranquillity of those who, out on a peaceful walk, are looking for a little quiet.

To counteract background noise and to communicate at all, people have begun talking louder and no longer hesitate to use a microphone to amplify the voice. The smallest lecture hall, the most insignificant theatre, is now fitted for sound, and the poorest singer can make himself heard by an audience of thousands and impose his dubious musical technique. The politician and even the teacher do not hesitate to use microphones and loudspeakers so as to reach more and more listeners, and thereby obtain an impression of wielding enhanced power—"they have been motorized", as Professor Mira y López wryly remarked; hence the interest now being taken in work on speech therapy and audio problems. The importance of the teacher's voice—its quality as well as its strength—is now appreciated. Certain recruiting examinations include a diction test, and in many teacher-training institutes future teachers have to undergo a course in speech training. On the audio side, the development of audio-visual techniques has demanded a more accurate knowledge of the auditory functions and certain new re-education techniques have led research workers to attach great importance to all audio-verbal connections.

This long introduction has indicated the necessity for dealing more completely with the audio aspects of the audio-visual situation. If audio research seems of less immediate consequence to educational psychologists than work carried out on the visual side, the opportunity can still be taken to draw attention to the scope it provides for scientific activity.

In this study we will consider the audio aspects from the psychological angle and, as in the case of the visual, ignore the general physiological problems of hearing unless they have a bearing on audio-visual situations, and we will try to compensate for the limitations of this approach by the variety of the points of view from which the problem will be regarded.

SUMMARY OF BASIC PRINCIPLES

Auditory perception occurs only when the components of the stimulus lie between certain frequency and intensity thresholds (we are referring here to pure sounds). Every sound emitted by an apparatus is characterized by its frequency and its amplitude. If a message is to result in a perception, its frequency must be approximately in the 20–2000 cps. range; sub-sonics and super-sonics may not be without effect on the organism as a whole, but do not give rise to perception in man.

Again, below a certain intensity threshold there is no perception, and beyond an upper intensity limit there is actually pain. Beyond this pain threshold the auditory apparatus can be partially or totally destroyed, and temporary or permanent deafness can follow if the intensity is too great (as in an explosion or bombardment).

Three of these thresholds can be measured in man (it would be inhuman to want to determine the pain threshold except for certain professional requirements and when a tolerance limit has to be established), and the classical audiogram constructed; a few words must be said about this to serve later in this study. The older form of audiogram was constructed with the frequency, expressed logarithmically, along the abscissa, and the intensity, expressed in decibels, along the ordinate.

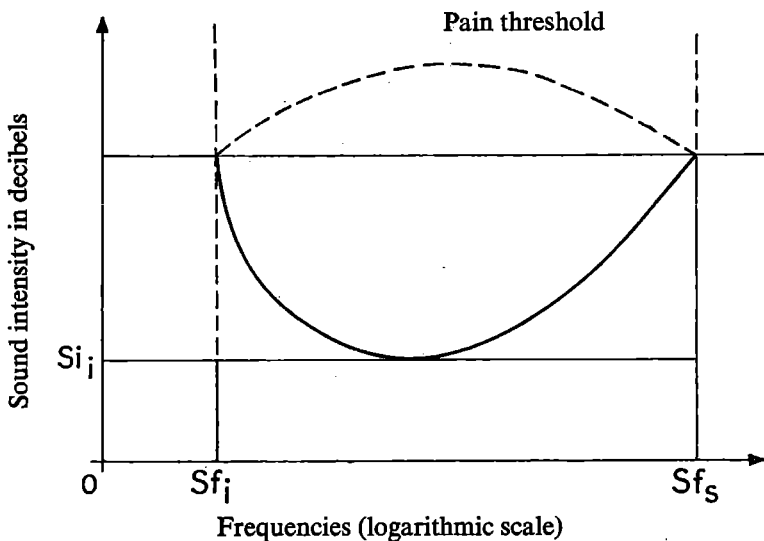

FIG. 13. CLASSICAL AUDIOGRAM

More recently these audiograms have been made more flexible. The absolute threshold is no longer measured as previously, but, for each frequency, the auditory defect of the subject in relation to the average, normal threshold is indicated. Accordingly, the audiogram of a subject whose hearing is normal for all frequencies would consist of a straight horizontal line at zero level. (See Fig. 14.)

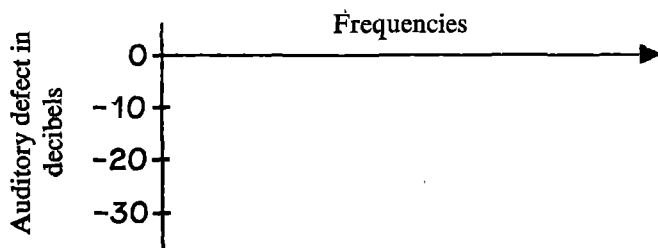

FIG. 14. MODERN AUDIOGRAM

Apart from individual audiograms which are fairly easy to construct, statistical-type phenomena have been illustrated, and Dr Tomatis even talks about an "ethnic ear" (207). According to him, great importance is to be attached to the auto-control of phonation by audition (Tomatis effect); the study of languages showed him "how the evolution of racial groups down the ages has led each, wholly involuntarily, to adopt a certain vocal mechanism composed of vowels and consonants whose pronunciation and quality are clearly differentiated from one group to another".

Below are given what, according to Tomatis, are the characteristic audiograms of certain ethnic groups.

French language

The figure, representing the specific auditory curve of French, shows a maximum selectivity at about 1500 cycles per second (cps.) and a second towards 250 cps., the difference in sound intensity between these two levels being about 20 decibels.

English language

It will be seen from the figure that English hearing is very sensitive to sharp sounds; in speech this leads to the emission of whistling consonants.

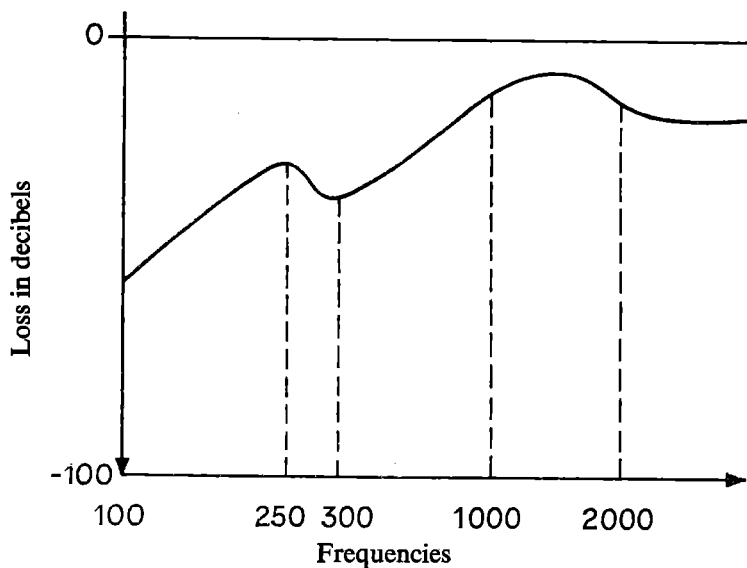

FIG. 15. AUDIOGRAM OF FRENCH

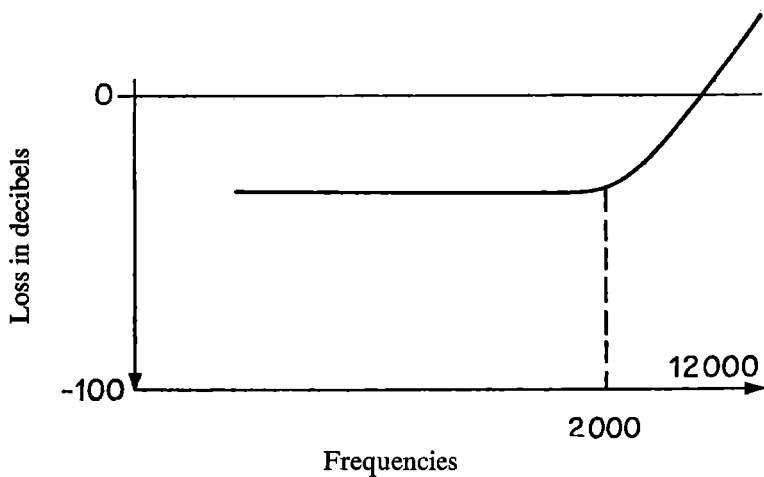

FIG. 16. AUDIOGRAM OF ENGLISH

German language

The figure shows how different German and English sound to the ear. Germans do not hear sharp sounds well, but are sensitive to the medium range. In speech this leads to a characteristic ejection of breath and a postural reflex.

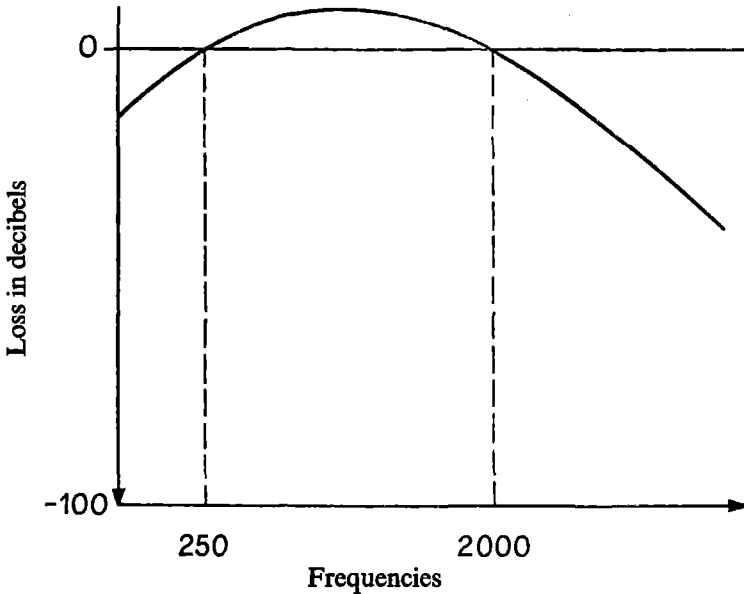

FIG. 17. AUDIOGRAM OF GERMAN

Spanish language

Fig. 18 shows exceptional sensitivity in the low tones and a very low sensitivity in the sharp, after a maximum towards 1800 cps.

The Slav ear is very receptive, and especially so towards the low tones. It accordingly can take all qualities, and the Slav vocal system can reproduce them easily.

Italian hearing is restricted, but it is specific for the high resonances which, in voice production, facilitate singing.

These points call for serious psychological consideration, and, before dealing with purely audio-visual situations, a few words must be said about the development of auditory sensitivity.

If we accept the results given by Tomatis, we are thereby accept-

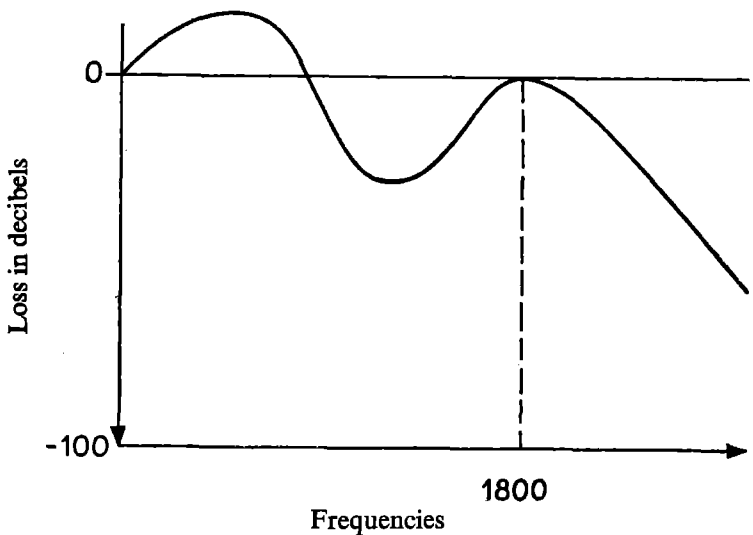

FIG. 18. AUDIOGRAM OF SPANISH

ing the idea of environment influencing auditory sensitivity—*i.e.*, the sounds heard during our lifetime, and particularly during early childhood, will act upon our vocal apparatus, and auditory sensitivity will increase over the frequency ranges of the sounds spoken by others, and diminish towards zero for the less frequently made sounds. This would partly explain why a child who had always lived with his grandparents in a remote part of the country and had therefore grown accustomed to hearing low-pitched sounds would give the impression in school of being deaf because he did not understand or did not hear the high-pitched voice of a young schoolmistress. This idea of partial deafness—*i.e.*, deafness for specific frequencies—is vitally important.

What is true in regard to the voice of the new teacher to which the pupil's ear has to adapt itself is *a fortiori* still more true in the audio-visual situation because, notwithstanding extraordinary technical progress, no loudspeaker actually reproduces the human voice. Research results are available, and we may here quote Piéron (177): "The main frequencies that govern intelligibility were empirically determined by emissions which were filtered so as to eliminate certain components. . . ." When all frequencies above 1000 cps. are cut out, only 27 per cent of English words will be correctly heard

(French and Steinberg, 1947), whereas 90 per cent can still be perceived if all frequencies below 1000 cps. are cut out (see the Tomatis audiogram for English above). The range necessary for full intelligibility is from 70 to 8000 cps. The critical zone is at about 2000 cps. in the sense that, if only the frequencies below or only the frequencies above 1900 cps. are maintained, there will be 75 per cent intelligibility (in both cases); this is confirmed by the data of Hirsch, E. L. Reynolds, and Joseph (1954). With a narrow frequency band of 1000 to 2000 cps., Egan and Wiener (1946) found that verbal intelligibility still amounted to 45 per cent.

A fairly large margin of variability is possible in the fundamental frequencies; changing the relative rotation speed of a gramophone between 0.6 and 1.8 reduces intelligibility by no more than 10 per cent.

These data all refer to English as spoken in America; the results would be different for the Latin, Germanic, or Slav languages. Unfortunately, precise experimental data are lacking in their case, and differentiating factors have not been sufficiently investigated.

Amongst the many causes of lack of comprehension we are referring here to two—the voice of the speaker and the technical quality of the apparatus. The difficulties two people living in distant parts of the same country and speaking with different accents have in understanding each other are like those of a child not yet fully master of his own language who has to talk with someone who has not exactly the same accent. Then there is the lessened intelligibility of the message due—according to the apparatus used—to the restriction of the frequency range. In the case of a living person or a cinema image, auditory perception is supplemented by visual, but when there is only a loudspeaker (radio receiver, gramophone, or tape recorder) a large part of the sound message is not correctly received and, because of the considerable modifications in their structure, cannot be correctly perceived. The teacher should never hesitate, especially with young children, to play a thing over several times in order to enhance comprehension, allowing familiarization to complete perception.

Certain phenomena that derive from the differential sensitivity to language and our perception of it (especially when learning a foreign language with the help of a tape recorder) must also be mentioned here. We found during recent investigations that children did not hear and accordingly could not reproduce English sounds whose wave structures were too close to those of their own mother

tongue. It appeared quite evident that when sounds were too close—*i.e.*, when the difference was less than the differential threshold—the teacher had great difficulty in obtaining a correct pronunciation, whereas with other sounds it was rapidly acquired. Modern equipment has undoubted advantages, but, taking into account the necessity of eliminating differences that derive from the technical characteristics of the recording and reproduction machinery, it will readily be understood that these are not a panacea for all teaching difficulties, and that they introduce certain complications which the teacher must remember.

Before finishing with these basic principles, reference must also be made to research on the perception of sound messages in noisy surroundings—a necessity in ordinary life as in the cinema. It is very rare—in fact, it is the exception—to be able to listen in absolute silence. It has been found that the lower intensity threshold depends upon the sound intensity of the environment. “The verbal auditory threshold is raised considerably by noise. When the noise reaches 100 decibels the threshold goes up to 80, and in tanks, military aircraft, and submarine engine rooms, it may go up to 110 decibels.” It may be recalled that, for certain frequencies, the absolute intensity thresholds are as follows:

Frequencies	128	512	2048	8192	16,384
Threshold (decibels)	40	15	6	20	35

There is an analogy here with audio-visual situations, where, in addition to the normal background noises, there are those of the apparatus and sometimes of explanatory remarks made by the teachers. This question was studied, note being taken of the percentage intelligibility of the speaking voice against background sounds of varying intensity, and with or without ear protectors. Kryter obtained the following values:

Intensity of sound	75	85	95	105
Intelligibility (per cent)	88	70	40	8

There should accordingly be no hesitation in suggesting to the teacher that, apart from exceptional cases, he should not disturb the audience by making additional remarks which lessen both the pleasure of the listener and his comprehension.

SPEED

A person can read more slowly if he wants to understand better, but things are otherwise in an audio-visual situation, since the messages are transmitted at a given rate, and the listener must adapt himself to the speed which is imposed upon him. In addition to the frequency difficulties referred to above, others are introduced by the rate of delivery. We all have friends who speak too quickly and we do not understand all they say and have to ask them to repeat themselves. Those whose knowledge of a foreign language is imperfect well know the difficulty they have in understanding persons who, although speaking the language at a normal rate, give the impression of speaking too quickly. Making a very cursory analysis, we may say that words have first to be recognized, thus introducing a stage between perception and comprehension (and this division is pretty arbitrary) which slows down the general process. The more familiar one is with the language, the more it is understood, the more practised, the more, obviously, will this recognition be rapid, and the general process correspondingly accelerated. Something analogous happens in the case of a child who does not recognize words he actually knows (leaving aside the question of words unknown to him which he does not understand) when pronounced by someone else or heard via a machine; immediate comprehension does not follow on perception, and the general sense of the message is distorted. Hence the younger the child, the slower must the sound message be—the important point of course being, not the speed of succession of syllables, but the general rhythm of the sentence. The slowing need not be uniform; it can take two forms—namely:

Normal: I am sitting in a cinema

I am sit ting in a ci ne ma

I am sitting in a cinema

In the first breakdown the proper structure of the sentence disappears, and comprehension becomes still more difficult despite an improvement in the components. In the second case pauses have been introduced which facilitate perception without losing sight of the general sense of the sentence, and facilitate comprehension of groups of words. This illustrates a result reported by Piéron (177): "A higher proportion of polysyllabic words is understood than of monosyllabic, and a much higher proportion of monosyllabic than of syllables which carry no weight, while the linking of words in phrases considerably increases their intelligibility."

THE RECOGNITION OF VOICES

Individual speech is made distinctive by the quality of the voice (the frequencies and their harmonics) and by two other features—speed and time structure or rhythm. (For obvious reasons we shall not deal in this study with the language content or richness of vocabulary.) By her way of pronouncing the famous line in Molière's *L'École des Femmes* "Le petit chat est mort" the actress playing the rôle could be recognized. This differentiation we make between the voices of other persons is certainly developmental and depends on the period during which the threshold becomes lower and lower, and allows the hearer to be increasingly confident in his recognition of the speaker. Little research has been done on this subject, and it would be interesting to know how a child identifies a voice heard on a radio, on a record, or on tape. With modern techniques rendering sound effects more and more complicated, this question becomes increasingly important. The difficulties will vary with the situation, and the listing which follows is not supported by rigorous scientific data.

1. *A single voice.* A child can distinguish between the voice of a man, a woman, or a child. There may be different affective tonalities—joy, sadness, anger, boredom, and so on. Observation shows that, in the absence of visual data, children—and even adults—are not very sensitive to these tonalities and do not perceive all the nuances necessary for a proper interpretation of the message.

2. *Several voices taking part in a conversation, or reciting (e.g., a play or story).* The preceding remarks are still relevant. In addition, the child has to notice that, apart from the fact that there are different voices (this is usually relatively easy), each belongs to a specific person—*i.e.*, he has to differentiate between auditory messages and recognize each as coming each time from the same source; otherwise misunderstanding will inevitably occur.

3. *Several persons talking without being in the same place—e.g., two persons engaged in conversation in the same room and a third participating from a neighbouring room.* Here there are a whole series of complications (a dialogue which can be understood by a third person, their asides, conversation with a third person some distance away, and so on) which are usually not correctly perceived by children, and considerable precautions have to be taken to prepare them and eliminate certain sources of incomprehension.

4. *Finally, there are 'voices off' added from outside, either to comment on a scene or to produce some moral or psychological*

effect (e.g., *the voice of conscience talking to Don Camillo*). A child has to be fairly old (at least 12 or 13) before these effects are correctly perceived and interpreted, because, psychologically, they presuppose the ability to achieve decentring and to stand back from the situation as a whole.

Training is in any case necessary and possible, and here audio-visual techniques open up numerous possibilities. Through exercises in the recognition of voice quality, the teacher can refine the differential perception of his pupils and thereby assist them in learning about the world and in acquiring certain skills such as spelling. Moreover, a child's comprehension of language cannot but be improved by accustoming him to grasp the affective nuances of sentences. The possibility of such exercises has been greatly increased by modern techniques (records and—especially—tape recorders) which, if properly used, should help to enrich the auditory sensitivity of twentieth-century children.

Recognition of one's own voice is something that must be considered apart. Tape recorders have become so common that it is now as easy to hear one's own voice as to look at oneself in the mirror. Everyone who has had the experience knows that he can scarcely recognize his own voice heard during a radio broadcast or on tape. What are the factors which disturb perception to this extent?

When we speak we do not hear only what others hear because our auditory perception does not result solely from the sound messages that are transmitted through the air. The perception of one's own voice is a synthesis of external messages, of proprioceptive messages, and of acoustic resonance phenomena, principally in the brain-pan. Of all these, the recording apparatus can be expected to be sensitive only to the sounds emitted by our vocal organs, and even reproduces only a part of them through mutilating and distorting frequencies and voice quality.

When one hears one's own voice on a tape recorder, both sources of distortion are operating, and it is easy to understand why recognition is not immediate. Only the speed and rhythm are the same; the other colorations which make an individual voice unique are too different to be accepted.

Nevertheless the tape recorder can be used as a kind of mirror to the class and greatly enhances teaching possibilities. A child can easily see his own body in a mirror, but has rarely if ever heard himself from outside, so to speak. The discovery of the body, the

acquired consciousness of the 'me' which is a fundamental element of the personality, has always stopped at the boundaries of the visual. And yet our voices and language are important parts of this personality, and many of our social relations are what our language make them. A soft and melodious voice will facilitate contacts with others; a staccato voice, poor in harmonics, may lead others to attribute to the speaker feelings and ideas he does not possess. These are things of which most people are not consciously aware, and the tape recorder can lead to discoveries which are sometimes of real therapeutic value. During the re-education of a girl who had difficulties with her mathematics teacher, we had occasion to provoke a reaction which in one sense was painful for her but constructive so far as her further social relations with others were concerned.

During recent experiments we have used the tape recorder in simpler circumstances to obtain a better understanding of certain aspects of teaching—*e.g.*, in teaching reading to primary-school children and in teaching a foreign language. Sparing the reader the practical details, we can say we have found that correction became more effective and learning more rapid. Contrary to what happens in the case of writing, drawing, or manual work, language leaves no trace, in the sense that the mistake which is being pointed out has disappeared, and very often the child does not understand exactly what the complaint is and this for various reasons: he forgets, he does not realize what was wrong, the differential threshold is too high so that he does not grasp the difference between what he said and what the teacher has said. With the tape recorder the mistake is recorded and can be reproduced. The child can hear exactly what it is. The teacher can analyse it with him, show him for comparison what he should have said (this is particularly easy with two-track tape recorders), and induce self-correction, the key to rapid learning. This is now a common way of acquiring a good accent in learning a foreign language;¹ in this way, too, we have also helped primary-school pupils to make rapid progress in reading aloud and in recitation.

GENERAL PROBLEMS AND OUTLOOK

Music has not been sufficiently used as a means of education because for a long time it was considered as one of the social graces,

¹ Mention will not be made here of all the teaching possibilities of the tape recorder.

a kind of luxury. Incompetent teachers and the impossibility of surrounding children with music from the start meant that music remained the poor relation of the other subjects in which it was easier for teachers to make a name.

We have just seen what a contribution modern sound reproduction techniques can make. Without going into all the teaching problems these techniques can help to solve, we may briefly describe what could well form the subject of a long chapter in a treatise on teaching techniques.

The dynamogenic character of music has long been recognized, and the need for melody is such that physical-culture instructors never simply count 1, 2, 3, but more or less sing "one and two, and one and two", as if it were really a tune; the movements are then carried out better, more completely, and more harmoniously. Teachers dealing with children who are delicate or need re-education because of some motor defect are well aware of the value of music. The influence of music on behaviour as a whole, physical and mental, has in recent years been recognized by the use of what is called functional music in industry.

Music also enriches us intellectually. In classical psychology the faculties were considered as being separate, and in the traditional picture of the human mind the exercise of reason was readily contrasted with the workings of the passions and of the will. This somewhat rudimentary view has now yielded to a more subtle concept of the relations between the various aspects of the individual personality, and it has become impossible to make so drastic a separation between some functions which are purely rational and others which depend upon feelings. Comprehension is a total act which may sometimes be disassociated from but is nevertheless affected by the various aspects of the whole situation. A larger comprehension, in which all the parts of knowledge and of emotion are integrated, must replace the cut-and-dried view which impoverishes the act of comprehension. It seems impossible to get the feeling of a historical period, for example, without hearing its music; without the music of Lulli, the Court of Louis XIV loses both colour and verisimilitude. To study the revolutionary period without Méhul is to ignore the enthusiasm which was one of the dominant features of this great period of history. What would romanticism be without Chopin, Berlioz, and Wagner? How can we understand the drama of the Negroes transplanted to America without knowing the Negro spirituals which so often reflect both their present distress and their

hope for a better world? It would be easy to show that historical understanding must necessarily be enhanced by music, which is one of the most typical manifestations of an age or a civilization.

The same applies if our understanding of certain aspects of geography is to be profound, if the object is to recall a countryside, a way of living, to understand the peoples of the earth better so that we can like them better and be better placed to help them. Why not have recourse more often to great works which, better than a long talk, illustrate subtle aspects which language can only outline or distort? The music of Albéniz and his dazzling *Iberia* or, at the other extreme, the music of Grieg with its picturesque *Norwegian Dances*; or the music of Sibelius talking spontaneously with the language of his native land in his *Legends* or his symphony *Finlandia*—all these allow us to go farther towards that real human understanding which should be the object of any education worthy of the name; beyond the realm of language which splits up reality into more or less rigid concepts, music provides a possibility of communication and discovery which, in certain respects, greatly exceeds that of speech.

But we must go still farther, because music ought to play an important part in the formation of the various intellectual skills through which an individual develops. One often hears complaints that no-one can spell, that children are inattentive in class, or have poor memories, and so on endlessly—but what is done about it, or, rather, what is not done? We notice that children do not hear very well, that they do not distinguish one sound from another. But in how many classes are their ears and their voices systematically educated? How many classes, either primary or secondary, have regular musical dictation, that exemplary exercise in concentration and in the differentiation of sounds? We know now the rôle which the ear plays in acquiring a foreign language, but how much time is devoted to educating auditory perception? It is readily agreed that observation should be developed, but it is forgotten that auditory observation is, in fact, also observation. It is interesting to see that in classes where ear-training is regularly given, the number of dyslexics—to use the fashionable word—is low, spelling mistakes do not exceed a reasonable level, and the children's mental progress is distinctly faster than in classes which confine teaching within the narrow limits of the traditional school subjects. In the school, music and choral singing are a unique source of pleasure to children, but, in addition, we can expect music to prepare them the better to

understand the music of poetry, to analyse and understand sensory messages better, and, in short, to be more satisfactorily adapted to modern life and both to understand it better and to make more of it.

It is recognized that sound media, and in particular the radio, can also have the national consequence of standardizing pronunciation within a country or a linguistic group. As was explained above, the effort of hearing made in order to take in and understand speakers on the national radio is not without its repercussions on the pronunciation and intonation of listeners who often hear the same voice. And, on a world scale, it can only be hoped that the ease of transmission of oral messages will help to bring men closer together, the best-written text or the most successful photo providing no substitute for the warmth and presence of a real human voice.

V. AUDIO-VISUAL ASSOCIATION

It was shown in the first section that the divisions introduced by language need to be compensated by a fusion of mental processes, and that, as a parallel to the apparent simplification introduced by words, there were corresponding perceptive operations that were very complex. The logical order of exposition hitherto followed—visual perception, auditory perception, and audio-visual association—should not be allowed to mislead. For the sake of clarity, problems had to be put into categories and synthesized. But we started out from the situation as a whole, and we must now get back to it and speak of research on audio-visual association and the respective rôles of the audio and the visual when their relative proportions vary.

There will be no need in this section to go again into all that has been said about the unity of perception; some data obtained in certain well-defined audio-visual situations will suffice.

RELATIONS BETWEEN THE VISUAL AND SOUND BANDS ON A FILM

Our first example is taken from the work of Carpenter and his co-workers, as reported by Nozet (167).

We will study an investigation of the rôle of various types of commentary on a sound film. The aim is to determine the effects of three components of the same commentary on the same film—namely:

1. The length, or, more exactly, the 'density', of this commentary in terms of words per minute of projection.

2. The way in which the commentary is presented to the audience: in the first person ("I do this"), the second person ("You do this"), in a passive form ("This is done in such and such a way"), or imperatively ("Do this").
3. The relation between the commentary and the visual part: the explanations about a scene may be given a little before it actually appears on the screen so as to prepare the spectator for what is to follow, or a little after so as not to blunt his natural curiosity and, once this curiosity has been satisfied, accurate observation can begin.

Teaching problems in the United States Navy were the basis on which the choice of film was made—on the subject of teaching recruits how to make three types of common sailor's knots.

It will be seen that this was a study of what part each of a number of specific components of the film plays in affecting the audience. No such experiment has ever been made before.

The three components selected proved well worth investigating, and their influence was found to be considerable.

The 'degree of verbalization' of the film means not only the actual number of words used on the sound track, but also the nature of the rôle these words play in relation to the visual part. Three levels can thus be defined: (a) 'Low': the actor's gestures only are described; (b) 'Medium': the relations between the various parts of the knot as it is being made are also described; (c) 'High': the various stages of making the knot are described in detail.

In defining the 'density', 'low' represents about 90 words per minute of projection, 'medium', 130, and 'high', 180. In general, in teaching films of this kind, the passive form is used ("A knot is obtained, a knot is made . . ."); advertising experts and some speakers, on the other hand, recommend the second person ("You do this"). When the teacher is under a greater degree of discipline, as in the Army, it was thought the imperative form might also give good results. Finally, so far as the relations between the commentary and the visual part are concerned, it was decided that the 'advanced' version would begin about two seconds before the corresponding scene appeared, while the 'delayed' version would start after a similar interval. As the three films made were fairly short, it was taken as a working hypothesis that the three variables could be considered as independent.

In measuring the effects produced by these different versions of the same film, it was considered that if the conventional method

of asking spectators to reply in writing to a questionnaire prepared beforehand were used, it would be very probable that the differences observed would not be statistically significant. As the aim of the films was to teach recruits how to reproduce a series of specific movements, they were asked to do the task proposed (to make a knot) following the projection of the film. For this purpose each spectator in the hall found before him an envelope with his name on it, each envelope containing string. The envelope was opened at the end of the projection, and each sailor immediately tried to make the knot. More than 1800 recruits took part in this test. They were divided into statistically equivalent groups in accordance with the results they obtained in a preliminary group test, designed for the Navy, and carried out the day after their incorporation into the various units.

Eight versions of the same film were made, each differing from the others in some specific factor. In comparing the effects of these factors, the statistical method used was the 'random-half control method', by which the necessary correlations can be established between the results of various groups and the rôle of each of the variables determined. The recruit was given the rating 1 when the knot was correctly made and 0 when it was wrong or unfinished.

The test carried out under these conditions gave rise to the following conclusions: as regards the 'density' of the commentary, the best results were obtained with the 'medium' version (about 130 words per minute) which described the relations between the various parts of the knot. The 'low' and 'high' versions gave results that were much the same as one another, but considerably poorer than those given by the 'medium' version. The imperative form ("Do this") was best for teaching recruits; the second person ("You do this") seemed to give results that were slightly poorer, but the difference observed was not statistically significant; the passive form gave by far the worst results. The best results were obtained with the 'advanced' version of the commentary, the one preceding the image by two seconds.

Following these experiments, the following recommendations were issued by the Navy to film producers.

- (1) For a given film there is an optimum density of commentary which should be determined before the editing of the film begins.
- (2) The imperative form should be used in the commentary.
- (3) Should it be necessary to draw the spectator's attention to some definite point in the image of the screen, the relevant commentary should begin before the image actually appears.

These results and recommendations should be known by any educator who intends to add a commentary of maximum effectiveness

to an audio-visual document. In doing so he will, of course, take due account of the nature of the document, the purpose for which he wishes to use it, and the level of the pupils for whom it is intended.

ORAL TEACHING AND VISUAL TEACHING

The interactions of word and image in the mental activity of pupils (one way in which the audio-visual operates) have been experimentally studied by a research team of the Institute of the Theory and History of Pedagogics, Academy of Pedagogical Sciences, Moscow, and a summary of the working document sent on this subject by L. V. Zankov (224) follows.

(a) *Aims of the investigation and experimental conditions*

The inquiry was concerned with the means of combining oral and visual teaching during a lesson, and the processes through which the pupil acquired knowledge in the different combinations considered. The authors were able to evaluate this knowledge by questionnaires completed before and after the lesson (either immediately or after a considerable lapse of time). In order to eliminate structural differences between the classes investigated, the authors made alternative studies—*i.e.*, in each class they alternately used two forms of combination of oral and visual teaching (indicated as Form I and Form III in the table below).

Class A Group X Form I	Class B Group Y Form III
Class A Group X Form III	Class B Group Y Form I

The authors explain as follows what they mean by different forms of combinations:

We used four basic forms in communicating new knowledge to pupils. Under Form I the teacher orally guides the pupil in the observations he makes, but knowledge of the external aspect of the object and of its properties and directly perceivable relations is acquired by visual observation of the object itself.

Each form of combination is defined in terms of the respective rôles of speech and visual means during the lesson. In Form I the teacher uses speech not to communicate knowledge out to

show the pupils how to observe an object, and so guides them in learning about its external aspect.

In this case the specific rôle of audio-visual means is preponderant. It is by observation that the pupil gets to know the external aspect of the object, and not by oral instruction from the teacher.

As an example we shall refer to a botany lesson for a fifth-year class on the cell structure of the leaf.

The teacher asks questions to which the pupils reply while examining a specimen. He says, for example, "Take a good look at the epidermis of the leaf: how are the cells arranged?"; "Look at the pulp cells: are they as closely attached to one another as the cells of the epidermis?"; and so on.

The lesson will, of course, not be limited merely to teaching pupils about the various leaf tissues: they will also learn that light traverses the transparent epidermis of the leaf and reaches the pulp cells, and so on. These parts of the lesson can be ignored, however, since they do not concern the directly perceptible properties and relations of the object, but facts which are not matters of immediate perception.

In contrast to this form of combination of oral and visual teaching, there is Form III in which the information about the external aspect of the object and its directly perceptible properties and relations are given orally by the teacher, this oral teaching being confirmed or made tangible by visual observation.

Taking the same subject as before for example, the teacher will personally give the necessary information: "The epidermis of the leaf is composed of closely adhering cells. The pulp cells are arranged in several layers which are spaced out and separated from one another by inter-cellular spaces." While the teacher is talking, the pupils examine the actual arrangement of the cells and their other characteristics.

Here, speech is the preponderant specific function: the information about the external aspect of the object is given orally.

The visual media serve merely to confirm and give body to the oral communication. The visual perception of the object gives no new information about its external aspect, everything necessary having already been said by the teacher.

These two forms are used in teaching pupils about the external aspect of objects and their directly perceptible properties and relations.

The other two forms (II and IV) are used in the study of interdependent relations between certain facts.

Under Form II, on the basis of observations which the pupils make and the knowledge they have already acquired, the teacher leads them by word of mouth to imagine and state relations which are not amenable to perception. In this case speech does not direct observation, but helps the pupil in interpreting the observed facts and in using previously acquired knowledge

selectively. The visual media serve as a basis for the comprehension of the relations between the facts.

Take, for example, a lesson on the battle of Marathon in the framework of the Medic Wars (Class Va). After talking about and explaining the main features of the clothing and arms of both Greeks and Persians, the teacher asks, "Which were the better armed, the Greeks or the Persians?"; "Why were they better armed?"; "Which form of clothing was more convenient?"; "Why?" The pupils will reply in terms of what they have observed.

As compared with Form II, Form IV has some special features.

Starting from observations made by the pupils, the teacher himself explains relationships between the facts which are not directly perceptible, draws conclusions from them, co-ordinates them, or generalizes. Here speech serves to communicate knowledge to the pupils about the interdependent relations existing between the facts.

In Form III the object is organically incorporated in the teaching process and confirms and gives body to the information verbally communicated.

In Form IV the object serves merely as the point of departure for an explanation during the course of which the teacher communicates data about facts and the relations which are not directly perceptible.

Let us revert to the battle of Marathon as interpreted under Form IV (lesson given in class Vb).

After giving details of the arms and clothing of Greek and Persian warriors, the teacher explains why the Greek army was superior to the Persian: "The Greek army was much better armed, its clothing more convenient and stronger than that of the Persians . . ."

(b) Results

Our investigation enabled us to determine the relative effectiveness of Forms I and III, the lessons referred to being typical.

Given that the botany lessons in the microscopic structure of the leaf have a major place in the study of its directly perceptible qualities, let us examine the relative effectiveness of Forms I and III.

Table A indicates the frequency with which Forms I and III were used in the lessons on the microscopic structure of the leaf, the figures indicating the total number of cases in which each form was used.

TABLE A

<i>Class</i>	<i>Form I</i>	<i>Form III</i>
Vc	10	8
Vd	0	15

In class Vc, Form I was used most often; in class Vd, Form III only was used.

Table B indicates the percentage of right, wrong, and no reply in the interviews following the lesson.

TABLE B

Class	Replies		
	Right	Wrong	No reply
Vc	76	4	20
Vd	42	11	47

The relation between the right and the no reply figures provides a quantitative indication of the knowledge of the children, the relationship between the right and wrong replies, a qualitative indication.

There is a clear quantitative difference. In class Vc correct replies are almost four times as numerous as no reply; in class Vd they are less numerous. There is also a corresponding qualitative difference.

An analysis of the exercises made as a check by all pupils in two parallel classes confirms these findings.

For other questions—"arrangement of leaves on the stem", "internal structure of the stem", and so on—the results were similar.

Form I also proved more effective in teaching geography and history. Its advantages for the study of the external aspect of objects were also demonstrated in the primary classes in object lessons and explanatory lessons on natural history.

Our inquiry showed similar differences as between Forms II and IV from a teaching effectiveness point of view.

The effectiveness of each form varies with the purpose of the lesson.

Let us compare, for example, the results of a lesson on the external structure of the leaf with those (already considered) of the lesson on the microscopic structure of the leaf.

TABLE C

<i>Number of times Forms I and III were used in the lesson on the external structure of the leaf</i>		
Class	Form I	Form III
Vc	11	12
Vd	0	16

A comparison between Tables A and C shows no difference between the two lessons. However, there was much less difference between the knowledge of the pupils of the two classes in the

case of the first lesson (external structure of the leaf) than in the case of the second (microscopic structure of the leaf).

This can be shown by comparing Tables B and D (Table D was prepared on the same basis as Table B).

TABLE D

<i>Microscopic structure of the leaf (Replies)</i>			
<i>Class</i>	<i>Correct</i>	<i>Wrong</i>	<i>No reply</i>
Vc	66	11	23
Vd	47	17	36

The difference in effectiveness between Forms I and III is less in the case of the second lesson because the study of the external structure of the leaf does not require the same differentiated and accurate observation as the study of the microscopic structure.

Accordingly, when the object requires a more thorough analysis, the difference of effectiveness between Forms I and III increases considerably.

As far as persistence of the knowledge acquired is concerned, Form I is also very effective; this was shown by analysing the knowledge relating to various external aspects of objects.

The relative efficiency of Forms I and III can be illustrated by Figure 19 (which does not express a quantitative relationship and is used for purposes of illustration only):

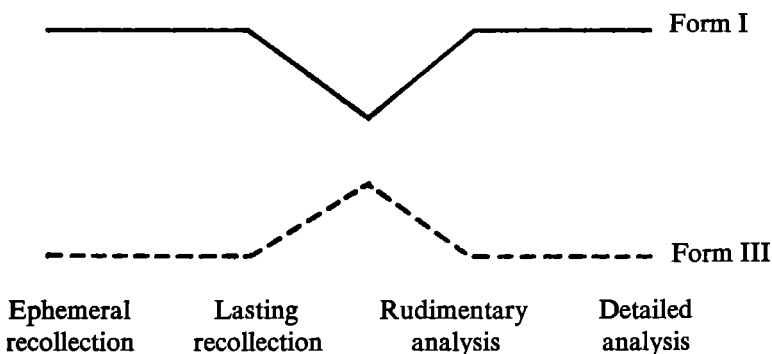

FIG. 19. INFLUENCE OF THE PSYCHOLOGICAL CONTENTS OF AN IMAGE ON HEARING

Such research, the results of which the authors have interpreted in the light of Pavlov's teaching, show one of the possible directions

experimental audio-visual teaching might take; starting from a precise analysis of the material to be taught and applied to education organized in different forms, it could help us to a deeper understanding and a more effective use of the equipment which modern technology places at the disposal of the educator.

LEARNING LANGUAGES BY AUDIO-VISUAL METHODS

Technological progress in the making of filmstrips and—particularly—tape recorders has given the problems of teaching living languages an entirely new slant. Without going into this whole question, one of international importance, some of the problems which are directly relevant here can be mentioned.

What are the basic hypotheses underlying audio-visual methods? They can be reduced to two—those relating to the audio-visual association proper and those which emphasize the importance of the auditory function in learning.

In general one can agree with Greimas (98) that

Irrespective of the method used, the teaching of a foreign language consists of superimposing, in the individual, two different linguistic systems: language A (the first language, the known language, or mother tongue, that is both a linguistic system which provides the general framework for communication, and a sign-culture system through which the surrounding world is regarded; and language B (language to be learned), also both a linguistic and a sign-cultural system, both differing more or less from those of language A. The science of teaching seeks the best method of superimposing languages A and B in such a way that the natural fluency in language A does not prove an obstacle to the acquisition of fluency in language B.

The audio-visual method is radical in attempting to insert prefabricated visual images between systems A and B, in setting up an adequate separation, an airtight partition between the two linguistic systems right from the time the acquisition of the new language begins. Operating syntagmatically, it attempts to establish each time a system of equivalences between a sequence in language B and the visual image on the one hand and, on the other, between the same visual image and a sequence in language A, ignoring the grammatical or verbal relationships between the two language sequences. The visual image thus serves as a kind of universal neutral relay: the image provides the equivalent of sequence B, but is understood because it can be identified with a sequence in language A, the language the pupil already knows.

In other words, it is no exaggeration to say that the image provides a psychological content which gives meaning to the phrase heard on

the tape recorder. Despite appearances, this association of the image and the verbal expression is not a simple one and raises a number of problems. The image has in fact a double rôle which can be stated as follows (98):

- (a) It must be understood by the pupil, and accordingly must be composed only of materials to be found in sign-culture community A.
- (b) It must at the same time translate all the grammatical and semeiological categories of language B, the language which is being taught.

The ways which can be used to impart an optimum comprehension of the image are varied, and the following are merely some examples:

1. A kind of limited common denominator can be sought—*i.e.*, in animal psychology, a schematic picture to distinguish birds of prey from friendly birds; in so-called primitive painting, pre-eminently sexual symbols; in child psychology, the stylization of children's drawings.
2. An investigation will be required into the specific autonomous visual semeiological systems of sign-culture community A (gestures, mimicry, and so on).
3. It will be vital to establish the distinctive features which go to make up the 'style' of the public to be taught: the sign culture in which it is situated, the cultural level, the mental age of the pupils, and the type of plastic arts it practises.
4. There is no reason why sets of artificial visual symbols based on conventions laid down at the outset should not be created. To a Turkish pupil, for example, a category of gender would seem absolutely pointless, and the adoption of different colours for feminine and masculine would represent a worthwhile artificial conditioning; similarly with grammatical categories difficult to visualize such as past-present-future, presence-absence, and so on.

Greimas then adds:

The audio-visual method consists in constructing, from an artificial visual code, series of visual signifiers, equivalent to parallel and simultaneous series of sound signifiers of linguistic system B, in order to obtain two kinds of result: (a) using an

exclusively visual code to cut the pupil off from his mother tongue A, so neutralizing its disturbing effect on the acquisition of language B; (b) so obtaining, for each thing signified, two different and equivalent signifiers, rendering it possible to make a transfer from the thing signified by the visual signifier to the new sound signifier in language B.

A major problem of all audio-visual methods now appears: that of constructing visual images which satisfy the above requirements. Here perfection is very far off.

It is, moreover, easy to anticipate the limitations of the audio-visual method so conceived. It may be excellent to start off with, but it needs radical transformation as soon as the level of verbal expression goes beyond what can easily be suggested in graphic form. Very fortunately for the intellectual development of the human race, language is not only the translation into a particular code of behaviour observable from outside; once more complex grammatical or verbal problems arise, subservience to the image must disappear. All this presupposes, however, that the teaching methods used in the first part of the learning period have adequately stressed the rôle of the auditory function.

This brings us to the second of the underlying hypotheses referred to on page 121. From the beginning of this century the teaching of living languages began to alter radically, what might roughly be called the direct method replacing the older method of translating texts. This has been followed in our day by the use of the tape recorder for teaching purposes. By devoting a full chapter to this one question it could be shown that there is both continuity and discontinuity between what the teachers of living languages were doing in 1930 and what they do or can do in the 1960's.

The main point, however, is that, as everyone agrees, the pupil must first hear, be plunged in right away, and so familiarize himself with the sounds and the melodic line of the foreign sentences he hears. As we shall see in a moment, there was even talk of auditory conditioning that derived first from the work of Pavlov and eventually crystallized in the concepts of Pressey, Skinner, and Morton.

Here again, however, we must go beyond the first approximations where everything seems clear and simple and discuss the various psychological problems which arise.

Right from the beginning the contemporary idea of teaching living languages by ear has included the behaviourist aspect, with all its advantages and likewise all its drawbacks. Watson, founder of

the movement, held that language should be considered mainly in terms of its motor components, and it is easy to understand the exaggeration of certain teachers who, blindly following these concepts which have since largely been dropped by Watson's own disciples, simply made up sentences and had them repeated for hours without worrying about understanding which, they believed, would come of itself. This sort of caricature was a feature of certain methods that were in use some years ago. However, the development of audio-visual practices and of educational and psychological research has led teachers to a more reasonable approach, and that the questions referred to below have been raised shows that critical evaluations have been made.

Reference must be made to the observation of Greimas that, in the audio-visual method, since language is taught as a sequence of spoken words, it is the 'word' and not the 'language' which has more or less hypnotized those who favoured the method. In consequence, they have regarded language as the sum of its words. The study of genetic psychology also played a part here. It has rightly been pointed out that a child learns to speak by ear only, and immersion in a given linguistic environment leads him to speak a language with a particular accent.

The auditory aspect can be considered at three different levels without it being necessary, however, to establish a hierarchy between them here.

Firstly, audio-visual methods develop the auditory memory, and thereby in a general way facilitate the learning of a language. In so far as a language is first of all spoken, learners can very profitably be allowed to hear native speakers talking amongst themselves—during a radio broadcast, for example.

Secondly, the rôle of the ear is fundamental in regard to pronunciation, rhythm, and the general melodic line of the sentence. In the light of what was said above about the Tomatis effect, it will be seen that ear-training will facilitate speaking and—the results are conclusive—a person who often hears the foreign language he is learning will have a much better chance of pronouncing it correctly and of making the most of his knowledge. Furthermore, thanks to its extraordinary value for purposes of self-correction, the twin-track tape recorder has provided living language teaching with a remarkably efficient teaching aid.

Thirdly, familiarity provides what almost amounts to a conditioning of the ear. A person who is not quite sure of an expression

(a conjugation, for example) in his own language seldom has recourse to grammatical rules in order to decide; his ear is usually the judge between two alternatives. When the ear has constantly to contribute to the learning process a kind of 'sixth sense' develops without which the learner will never be at ease when he talks. Again, this constant training of the ear makes it easier to recognize another speaker's words and expressions. It is not enough simply to have a large vocabulary. Knowing a language is more than just being able to speak it; it also implies being able to understand and recognize what the other person says. When that stage is reached, all acquisitions become immediately useable, and progress is rapid. All these elements accordingly are important in encouraging people in the learning and handling of a language.

CHAPTER 3

FURTHER PSYCHOLOGICAL ASPECTS

INTRODUCTION

In the light of the first seminar and the specific object of this study, we decided to enlarge upon basic problems and merely sketch in the remainder, while indicating the main trends which research may take. This chapter is accordingly somewhat fragmentary, and reflects the optimistic view that what is still not clarified will be considered in further seminars and studies. The next series of psychological phenomena to be discussed is still more complex than those so far dealt with, and in the face of this complexity the amount of research done seems relatively little. Such research is admittedly difficult, and for three kinds of reasons: the present complexity of psycho-social phenomena, the varying degrees of familiarity of spectators with the cinema, and technical changes which may themselves very rapidly cause general conditions to change. In other words, a chapter on this subject need never end: at any given moment the whole psychology needs to be considered anew, and even then conditions are changing all the time.

We shall, therefore, opt for certain major themes and deal with them, supplementing them, whenever possible, with strictly controlled scientific results.

I. EMPATHY PHENOMENA AND THE BEHAVIOUR OF THE CHILD SPECTATOR

It may seem undesirable to use the word 'empathy' in a title, but it seems to describe best the group of phenomena which are now to be considered. A celebrated and remarkable article by Professor Michotte has greatly helped in clarifying our own ideas (163). Empathy phenomena, he says, "occur when a spectator of an action performed by another person 'lives' it himself to some extent and

does not merely try to comprehend it in a purely intellectual way by classifying it into one conceptual category or another." Psychologically speaking, therefore, we have gone beyond comprehension and are concerned with 'projection' phenomena—a term which has different meanings for different schools of psychology and is more ambiguous than 'empathy' as defined above.

In trying to understand the nature of empathy phenomena one naturally turns to the motor component of the personality. Reference was made above to the position taken up by H. Wallon on this subject; the following is Michotte's description:

Watching certain motor performances such as dancing, acrobatics, tennis, or football, we may react in very different ways to the visual spectacle—*e.g.*:

1. Sometimes—but rarely—a visual spectacle remains isolated from the motor reactions of our own organism. That can happen especially when, looking at an actor or actors, we are ourselves occupied in carrying out movements altogether different from those we are watching. From the point of view of perception, there is then a complete segregation of the visual impressions of what we see from the tactile-kinaesthetic impressions that correspond to our own movements.

2. In other cases our movements harmonize with those we are watching and seem to be governed by them—*e.g.*, the hand or foot automatically beats in rhythm with the movements perceived. Segregation may continue, however, in the sense that we realize that our movements, perfectly distinct from those we are watching, are simply synchronized with them (parallelism between different events).

3. It also happens that the similarity between the reactions of our organism and those of the actor become closer, and this can be carried to the point where the spectator openly imitates what he sees. Most often, however, the spectator's reactions are less marked, possibly incipient movements which are generalized and affect the whole of the motor apparatus. When that happens there is usually a real fusion between the visual data (movements of the actor) and the proprioceptive tactile-kinaesthetic data (movements of the spectator), to the point where, for the spectator, there is only a single movement, and things are happening in more or less the same way from his point of view as when he watches one of his own limbs moving.

However, the fusion is limited to the motor manifestations, and it does not extend to the actual persons involved. The actor remains the individual perceived on the screen, distinct from 'me', the seated spectator, the first being present in the form of visual impressions, the second as tactile-kinaesthetic impressions. This situation could be described by saying "I feel what the other is doing"; while remaining myself, I have the impression of feeling

what is happening inside another's personality. To put it in more abstract terms, there is a single action under two forms (visual and proprioceptive) but it 'belongs' phenomenally to two different persons.

4. Finally there is the extreme case in which the identification extends to the actual persons involved. As Litt (137) says, there is then only a single empathized 'I' projected into an external object. In this case the actor no longer appears to be a distinct person, and the spectator ceases to be a person seated in the audience; he 'gets into the actor's skin', to use a popular but accurate image. Now there is only a single person, 'I' in the actor's body and, naturally, only a single action as in the preceding case.

These are phenomena, as Michotte says, "difficult to imagine", but real enough, as everyone will know from his own experience of the cinema. To explain these empathy phenomena more fully, Michotte analyses the perception of movements (see above), but it must be admitted that all the problems are not thereby solved, and he continues:

The case of complete identification in which the person of the spectator merges with that of the actor introduces new difficulties, however. In this case there is no longer just a merging of more or less different movements, conditions, and characters all reacting together, but the apparent incorporation of the ego in another person, and this seems contrary to common sense.

Before discussing this point it will be well to examine the manifestations of emotional empathy to which are closely bound the empathy of feelings, of mental attitudes, of judgments, of thoughts—empathy of all the categories of happenings which seem to us intimately linked to our deepest self, the 'I' which is ourselves in the full sense of the word and which we spontaneously consider apart from our bodies.

It is not difficult to find parallels here to the cases described in dealing with movements.

In the theatre or cinema the empathetic projection is made for preference to the hero or heroine, the character who, for one reason or another (physical attraction, the sentiments he expresses being also those of the spectator, and so on), stands out from those other characters whose actions create the environment and the situation in which the hero finds himself.

The relations of empathy between spectator and hero are of different kinds:

1. They may be altogether absent when the emotions of the hero are quite different from those the situation produces in the spectator (*e.g.*, the actor's anger seems funny to the spectator).

2. There may also be a simple parallelism—*e.g.*, a character addresses certain criticisms to the hero which could very well

apply to the habitual behaviour of the spectator, who, accordingly, and independently of the more or less similar annoyance the hero shows, feels personally involved. The same sort of thing is usually reflected in common expressions of the type: "I'm very glad for you" or "I sympathize with you".

3. It can also happen that the spectator's private reactions and the actor's expressions exactly match and fuse, although both remain perfectly distinct persons. The classic and most obvious example is the understanding of another's speech. The listener perceives by hearing the sounds made by the speaker (movements of expression), and these sounds evoke in him the meanings he has learned to give them; he nevertheless has the impression of directly perceiving the speaker's thoughts in the actual words.

The same thing, incidentally, happens affectively when the spectator sees his own feelings expressed on the actor's face or, conversely, has the impression of feeling the emotion the actor is expressing.

4. The case in which the spectator identifies himself with the hero is so common and has been so often described that it seems scarcely necessary to go into it here.

This case, however, raises a vital question. The previous ones do not seem to offer any other than motor reaction difficulties, and they also can be interpreted in the light of the organizational principles which govern integrations and segregations in our experience.

On the other hand, it seems at first sight inconceivable that our 'I' can be projected into that of a character we see on the stage or screen and that we can identify ourselves with him. This is a major problem. We must start by delimiting the data exactly and, first of all, the idea of the 'I' which is involved here.

Each of us is convinced of the existence of his 'I', real and substantial, the original source and support of his activities, feelings, wishes, and so on. This concept is not based, however, on the presence, amongst the data of personal experience, of what can be called the 'object-I'. That would be contradictory because if it were an 'object' it could not be 'I'; this, moreover, is the reason why the body which we can perceive as an object by touch and sight remains distinct from the 'I'. The body is 'mine' without being 'I' in the full sense of the word.

Hence the 'I' does not and in fact cannot appear to us except in the form of activities experienced—*i.e.*, not in the form of things but of processes. In the normal conditions of existence, however, we localize these processes in the body, and they seem linked to it in a certain way.

From the point of view of vision and external touch, the movements the body executes belong to it in the same way as any movement belongs to the object which is its carrier. Internally, however, these movements also possess a special form of subjectivity (called by Claparède the "half character" ("*caractère de moitié*")

which makes them appear to us as being 'our' movements. They constitute one of the most important aspects of the phenomenal body, and it can be stated that our movements, although by nature processes, are our body in action.

That once said, it is clear that the complete identification of the spectator with the actor presupposes that, phenomenally, all these processes belong exclusively to the visual object, the actor.

Supposing that this could happen, the spectator would necessarily have the impression that his actions were taking place in the 'actor', the impression that the actor's body had become his own since he 'feels' this body which he sees moving, and, as has just been said, to feel one's movements is to feel one's body in action. Similarly, the actor's playing would be, for the spectator, the expression, the appearance of his emotions and feelings. In short, the spectator will have 'become' the actor or, alternatively, the visual aspect of the actor will have become the external aspect so to speak of the spectator's person.

But how can this happen?

It is known, of course, that, in accordance with the principles referred to above, the correspondence between the actor's movements and the more or less similar movements he induces in the spectator, and the correspondence between the affective expressions of the actor and the emotions felt by the spectator tend to bring about a fusion of these processes. Since, moreover, his movements and expressions naturally seem to belong to the visual-actor-object, it is conceivable that this link extends to all the processes which are fused by the movements and expressions.

All this would be fairly easy to understand if the processes taking place in the spectator were not also related to other aspects of his corporeal 'I' which seem to deny this new link of belonging.

Sitting in his place, he receives sensory messages which should inform him, *inter alia*, of the position of his body (his sense of posture), and of his contacts with the seat. His visual impressions should enable him to localize the place he occupies in relation to his surroundings. He knows his own face and appearance from having seen himself in mirrors, and should realize that all he is feeling relates to this face and not to the other, normally wholly different face of the actor. The reality of the character of the actor that appears on the screen in the form of an image should be much less than the reality of his own body, and so on.

One very important condition of identification is the intense and exclusive concentration of the spectator on what is happening on the screen and in particular what is happening to the hero. Usually he almost completely dissociates the world of the screen from that of the auditorium, sometimes to the extent that the hall disappears completely from the spectator's perceptive horizon (the well-known phenomenon of negative abstraction).

Study of the perception of movements and their combination

constantly indicates the dominance of the dynamic over the static. In particular, kinetic impressions remain unchanged despite radical changes—of colour, form, dimensions—which the moving bodies themselves are made to undergo. Hence, in the present case, the impressions of movement and the affective processes of the spectator dominate, leaving in the background or even eliminating his impression of position and so on. Similarly, in the case of the actor, his playing dominates the impression of his personal appearance.

Finally—as has often been pointed out—the total effect of the spectator's surroundings (the darkness of the room, the brilliance of the screen, the rhythm of retinal excitation, the sustained attitude of careful attention, tiredness, and so on) is such as to induce mental states which sometimes approach the abnormal and encourage the mental dissociations which complete identification demands.

These analyses give us a better understanding both of the scope of the cinematographic action and the fatigue which may result from it. They also form a useful introduction to the experimental research carried out by Madame Leroy-Boussion on the emotional behaviour of the child spectator in the cinema. The following is taken from the report I made during the Caen Seminar:

Our research centred on the relationship between the film and the child spectator, and refers to an age group still little explored from the angle of the psychology of the spectator's reactions to the screen: the 4-14 age group, covering kindergarten and primary school.

Our central question was that which all makers of educational films must ask themselves if they want to produce teaching films that will really be adapted to the particular mentality of school-children who are still young—namely, "In what way does the child spectator differ from the adolescent spectator? In what way, *a fortiori*, does he differ from the adult spectator?"

In common with all the work reported on here, our research starts with a question: "Is it or is it not possible to reveal, clearly and coherently, the laws of the psychological evolution by which the child spectator is progressively changed into an adult spectator?"

Apart from what it had in common with other studies, our research diverged in two important respects:

- (a) It was concerned with child psychology and not with filmology or education.
- (b) It was essentially concerned with infant affectivity, and not centred on the problems of intellectual acquisition. The working instrument used as a test was the recreational and not the teaching film.

It is the first investigation of a series, and as such was kept to a deliberately limited theme—the expression of emotions in child spectators.

Film projection is extremely helpful to the psychologist who wants to study emotion in children. Similar situations can be projected at any time for subjects whose experience is different, and the investigator can change at will various factors—age, sex, intellectual development, social background—which characterize each of the subjects, and so make fruitful comparative studies.

We projected the same recreational test film before a large number of schoolchildren. On the basis of this absolutely standard film material, we studied the evolution of the changes that occur in the emotional behaviour of the children from one year to the next, taking due account of possible differences between the boys and the girls.

The main object in this first testing was methodological in character; we were trying to establish comparisons in terms of figures so as to make the study of the reactions of child spectators as clear and simple as possible.

This methodological aspect will doubtless be of most interest to teachers and film-makers; they will realize at once that the procedures used are directly applicable to the teaching film.

From this point of view the conclusions from our results are very encouraging. Despite the multiplicity of factors that help to start off a reaction in child spectators, it proved possible, as will be seen, to construct very coherent and regular age curves for the different behaviour patterns of children watching a film. An interesting mode of investigating children's cinema is thus opened up: the reactions caused by film stimuli lend themselves well to genetic research on the basis of numerical comparisons.

More specifically and practically, the age curves we are going to show will still further confirm the conviction that teachers may already have on one essential point: there is not 'a' primary school audience in the cinema; there are really as many different audiences as there are years of age between 4 and 14.

It will be seen from these genetic curves that the psychological evolution of the child spectator is extremely rapid and that important changes in reactions can appear from year to year. The film sequence that is very effective at 8 years of age will not yet be so at 6, because it would then be premature; at 10 it will no longer work because it is too late. Modern school textbooks are designed for specific classes—*e.g.*, elementary; first year, intermediate; second year, etc., and addressed quite specifically to 7-year-olds or to 10-year-olds. The same should apply to teaching films. To be effective, each short teaching film must be designed for a specific class and a definite age group.

Let us go further. It is likely that the very stuff of our investigation—namely, a study of emotions in child spectators—will not be a matter of indifference to teachers who want to make

teaching films for primary schools. At this school level it is almost impossible to make a cut-and-dried distinction between the recreational and the purely didactic film. When dealing with very young children it is difficult to unravel the "intellectual acquisition-affective resonance" complex. Many children in the younger classes retain a new idea in school only in so far as it is presented to them in a context which engages their affectivity, whether it be funny, comic, moving, troubling, or frightening. The maker of teaching films for the first primary classes will often be obliged to dress up the ideas he wishes to teach in terms of a small play with some emotional content. He must address himself to their affectivity, the more so since teaching by film momentarily separates the child from the teacher, temporarily eliminates the direct person-to-person relationship in the learning process in the child, and cuts the powerful affective link which ordinarily exists in the class between the very young pupil and his teacher. However, it is not always easy to make up such a play. In trying to prepare more or less moving sequences which will touch the child's heart and provide an emotional background for the absorption of some new element of school knowledge, the film-maker will come up against many problems. His audience will have plenty of surprises for him: outbursts of uncontrollable laughter where he expected pity or tenderness, indifference and total lack of response where he expected them to be moved, anxiety that is inexplicable to the adult mind, unpredictable fears—often violent in the very small children—where a hearty laugh was expected.

In common with the psychologist, he is then forced to make a genetic study of the emotional behaviour of children in the cinema.

We used only one test film in our experiments—a twenty-minute Chaplin film, *Charlie at the Spa*.

This comic test film, chosen from many after a large number of trials, made the older children in the primary school laugh a lot, began to be amusing for the smallest, and caused practically no reactions of fright. As will be seen, we deliberately kept away from disagreeable emotional tonalities such as fear or anxiety, and purposely chose an extreme example of as precocious and open-hearted a comic film as possible.

The films were shown in those infant and junior schools in Marseilles which had joined the local educational cinema office. The test film was included in the normal teaching cinema programme as a recreational supplement. The showings were given early in the morning. The test film was projected at the beginning of the programme, before the teaching films. Neither pupils nor teachers were told that a psychological experiment was being undertaken.

The audience at each showing consisted of about a hundred children of different ages. The audience, therefore, was always numerous, lively, and warm. Each child found himself in

absolutely normal and natural conditions, in his own school, among his usual classmates.

The test film was shown in 222 schools—that is, before 222 different child audiences.

The study was made by the direct clinical observation method, applied at the individual level.

During each showing one single individual was observed. We chose him at random in the hall, situated where part of the audience was slightly illuminated by the projector beam directed on the screen.

The greatest discretion was used in watching reactions. The investigator waited until the lights were turned out and the children gripped by the film before sitting down about six feet away from the subject. Notes were taken in the semi-darkness, without a lamp.

The investigator (always the same person) observed the play of facial expressions, body attitudes, movements, cries, exclamations, laughs, and smiles, and noted each of his impressions.

Each reaction, whether imitated, spoken, or acted, was immediately noted in writing and related back to the exact part of the sequence which had given rise to it.

So far as time allowed, each emotional reaction was described in two different ways in terms of two different and complementary points of view:

1. The synthetic, rapid commonsense view—the ‘label’ which the daily routine of social life teaches us to place right away, without thinking, on a collection of complex reactions—*e.g.*, “burst out laughing”, “chuckle”, “smile”, “fright”, “terror”, and so on. To this qualitative label a rough appreciation of the intensity of the reaction was attached.
2. The analytical view of the psychology of emotion which doubts the existence of permanent structures in the external manifestation of various categories of emotion. We no longer interpreted the reaction, but merely made as detailed an analysis of it as possible. We tried to fill out the synthetic appreciation, the commonsense label just attached to the reaction, by an objective description of certain essential motor components of this reaction (*e.g.*, rocking backward and forward or jumping in his seat while he “burst out laughing”, bending double in a great outburst of laughing, movements of self-defence, protection or biting of fingers when the label “fright” was attached, and so on).

Once the experiment was complete, this two-stage appreciation, made from two different and complementary points of view, enabled us to check the accuracy of the necessarily rough ‘labels’ and to attempt a genetic and differential study (including sex and

age) of the gestures, attitudes, and motor manifestations linked to the different qualities of emotion shown.

The experimental sample consisted of 222 subjects taken as follows from throughout the 4 to 14 age group:

<i>Years of Age</i>	<i>Boys</i>	<i>Totals</i>	<i>Girls</i>	<i>Totals</i>	<i>Grand Total</i>
4	15		15		
5	15		15		
6	15		15		
7	15		15		
8	15		15		
	—	75	—	75	150
9	9		9		
10	9		9		
	—	18	—	18	36
11	5		5		
12	4		4		
13	4		4		
14	5		5		
	—	18	—	18	36

Using these data, we opened up some new lines of research on three different points.

1. The ability of film stimuli to provide laughter or fear in relation to the age and sex of the children (analysis of the 'labels', the data collected by synthetic, commonsense evaluation).
2. The structure of reactions (gestures, attitudes, vocal noises linked to the emotions); analysis of data relating to the motor manifestations of the body and limbs that accompanied a surge of emotion and constitute the essential components of the externalized reaction—the analytical view of the psychologist.
3. The collective character of the emotion—the inter-individual relations shown by children looking together at the same emotionally stimulating film.

An important methodological observation must be stated here. Fear, anxiety, terror, sadness, and pity are complex emotions reflected in expressions, postures, and gestures which are difficult to observe and are often contradictory (*cf.*, Wallon: "ictus" fear and "raptus" fear). In view of this difficulty, often referred to by psychologists, we purposely limited ourselves in this study to two very rough categories when making our analysis of the commonsense 'labels': agreeable emotions (amusement), disagreeable emotions (anxiety, fear). Recent psychological work (*e.g.*, Schlosberg) on the validity of judgments made on the basis of manifest emotions seems to indicate that there is, to say the

least, a considerable differentiation between the two emotional poles of agreeable and disagreeable, between 'joy and amusement' and 'sadness and fear'. In our study, 'fear' covers real fear and various shades of 'disagreeable' emotion such as anguish, anxiety, sadness, and so on.

FIRST SET OF RESULTS

Our first set of results relates to the effectiveness of the stimuli.

1. We found that there was nothing which was comic or laughter-provoking in itself, but things were found to be comic according to the child's age. The sense of the comic and the child's laughter became progressively more sophisticated with age.

Fig. 20 shows that the older the children were the more often they laughed.

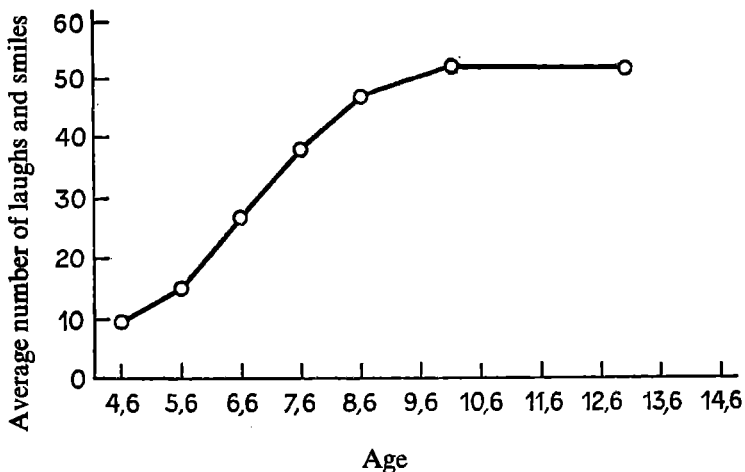

FIG. 20. EXPECTED RESPONSES: INCREASE IN LAUGHTER AND SMILES WITH AGE

Age is shown along the abscissa (between 4 and 14 years), and along the ordinate the average number of amusement reactions (laughter of all intensities, smiles) observed during the twenty minutes of the film projection. Each point along the curve accordingly indicates the average number of laughs and smiles for each age group, and the curve as a whole shows the rate of increase of amusement reactions (laughs and smiles) with the increase in age.

It is clear from the graph that some comic sequences affected children at a much earlier age than others. The older the children were, the more were the comic sequences which 'worked' and

the more effectively did the 'gags', working as the director intended, make the audience laugh or smile.

2. We noted a clear difference in the number of amusement responses of boys and girls respectively. The small girls were much slower in developing the comic sense than the small boys.

Fig. 21 plainly illustrates this difference. As in the preceding graph, the different age levels are given along the abscissa and the average number of laughs and smiles observed during the projection along the ordinate. The unbroken line shows the increase in the number of amusement reactions (laughs and smiles) in the boys, the broken line that of the girls.

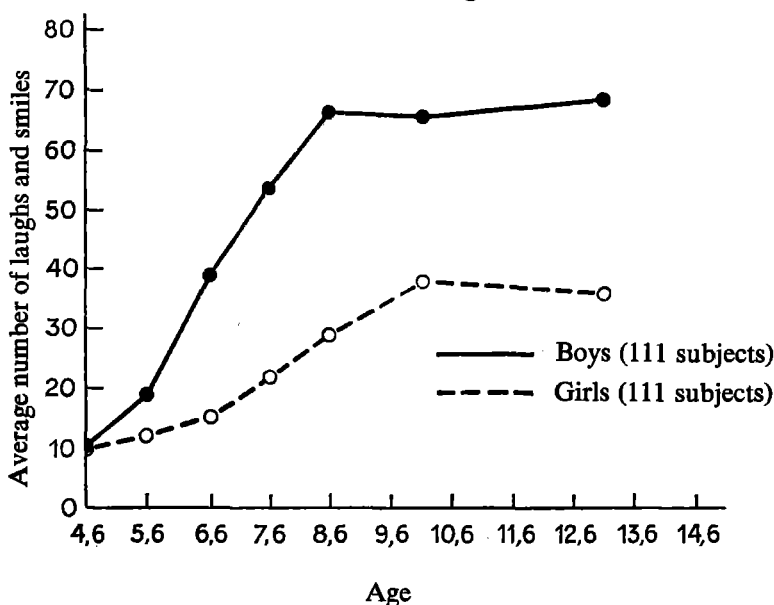

FIG. 21. EXPECTED RESPONSES: INCREASE IN LAUGHTER AND SMILES WITH AGE. (DIFFERENCES BY SEX)

Generally speaking, the boys laughed or smiled twice as often as girls of the same age. There is a gap of at least two years in the rate of approach to maturity. Broadly speaking, at each age level the girls' behaviour so far as laughter was concerned was that of boys two years younger.

3. The quality of joyful emotional reactions, the way in which laughter varied, also depended upon the sex of the subjects.

Not only did the girls at all ages laugh less often than the boys, they also laughed with less intensity. They were less exuberant and more discreet in their reactions of merriment. This was reflected principally in the abundance of smiles (intensity 1) and quiet laughs (intensity 2).

For the same number of reactions of merriment and amusement, the highest intensity levels were principally amongst the boys. The bursts of laughter (intensity 3) and the great fits of laughing (intensity 4) were, *mutatis mutandis*, more numerous amongst the boys than amongst the girls.

Hence qualitative differences were joined to the quantitative, and reinforced them. An interesting fact for the psychologist concerned with the influence of the social environment on the expression of emotions is that these qualitative differences between the sexes exist at a very early age, at 4 and 5 years, even when boys and girls go to the same school (our infant schools are mixed), pass their days together, and have the same school environment.

4. A statistical analysis in which the influence of age and sex was eliminated enabled us to evaluate the relative weight of the intelligence and socio-economic level factors in inducing laughter at the sight of the stimuli used.

The analysis showed slight but significant variations in the frequency of laughter in relation to the intelligence level of the subjects (the less intelligent children laughed less than the others; those who laughed loudest were mainly those of average intelligence), and also in relation to the social background (those from

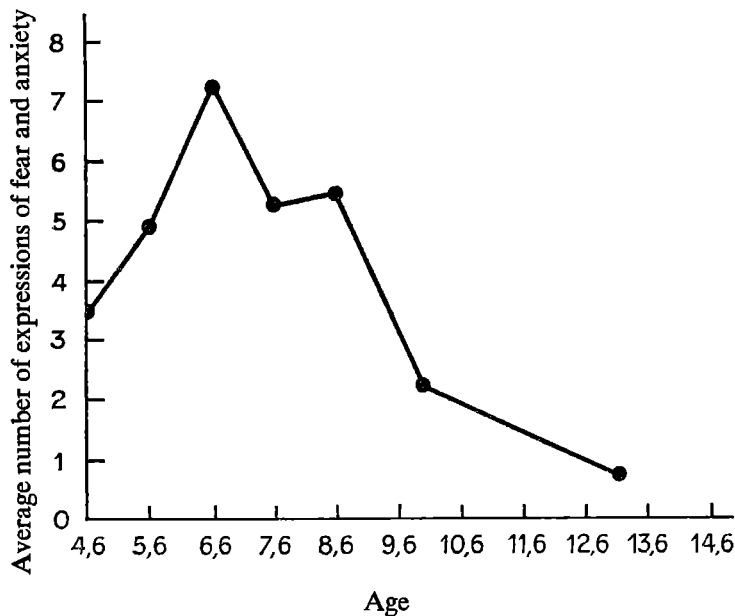

FIG. 22. UNEXPECTED RESPONSES: STRONG FEARS AND ANXIETIES—DEVELOPMENT WITH AGE

the rural suburbs laughed less often; those from the poor, crowded districts tended to be extreme in their behaviour, laughing either very little or, at the other extreme, enormously).

5. The very young spectators were extremely vulnerable to fear. The test film was unequivocally comic, but caused reactions of *fright and anxiety and sometimes even of terror and anguish* in children from 4 to 8 years old. Fig. 22 illustrates the development of these specifically childish fears. As previously in the case of laughter, each point on the curve corresponds to the average number of disagreeable reactions (fear, terror, anxiety, sadness, anguish, and so on) observed in a subject within the age group in question.

It was found that, towards the end of the age group (9 to 15 years), these reactions of fear and anxiety had practically disappeared, and they thus truly reflect a specifically childish attitude.

These are experimental data which should serve as a serious warning for those who work in the cinema and television. The fact is that, during a show, very young children are overcome by entirely childish fears which adults are wholly incapable of foreseeing.

6. Girls are much more vulnerable to fear than boys of the same age. The regression of childish fears and anxiety was much slower in girls than in boys. Fig. 23 shows clearly the extent to which the two sexes differ in the frequency of appearance of reactions of fear during a showing. The unbroken curve indicates the average number of times fear and anxiety were observed in boys relative to age; the dotted curve gives the same information for girls.

The graph shows how different the girls and boys were in regard to reactions of fear.

In general, the girls were frightened twice as often as the boys. As in the case of laughter, the development in regard to fear shows a gap of two years as between girls and boys respectively; at each age level the girls behaved like boys two years younger.

Other statistical analyses of these fear reactions showed that qualitative differences accompanied the quantitative differences just mentioned. The girls were frightened not only more often than the boys but more violently. For the same frequency of appearance and the same age, the reactions of fear and anxiety were always much more intense in the girls than in the boys.

7. The same sequence which caused outbursts of laughter in the older children (9 to 14 years) might cause very violent reactions of fear in younger children (5 to 8 years).

Showing the same comic scene first to very young children, then to progressively older groups, it is often found through the age levels that there is a curious phase during which the affectivity is completely reversed: as they grow, the children pass from fear to the opposite pole of laughter and amusement.

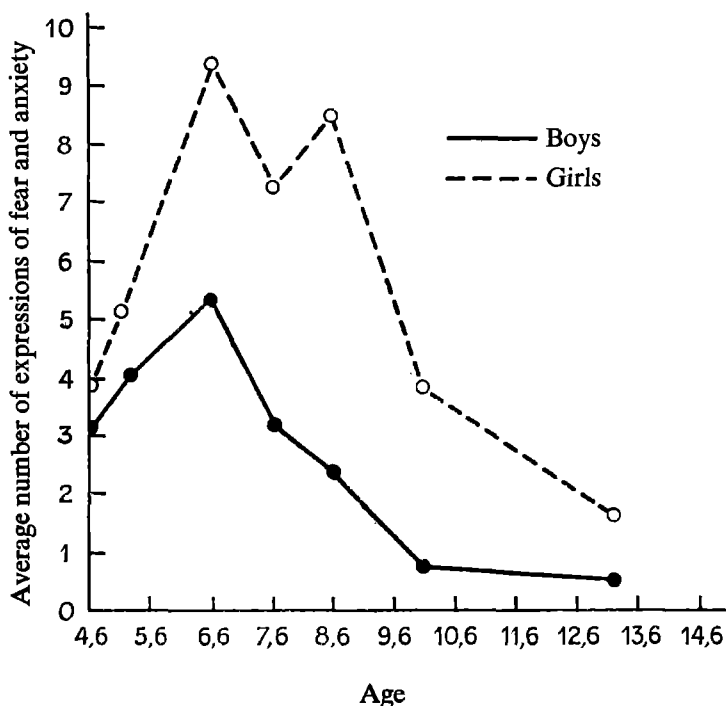

FIG. 23. UNEXPECTED RESPONSES: STRONG FEARS AND ANXIETIES—DIFFERENCES BY SEX

Thus fear often precedes laughter chronologically in the emotional behaviour of child spectators. At a certain level of maturity the two criss-cross.

8. In the middle of this change of emotional tone, precisely when the change-over occurs, we observed a rather unusual type of emotional behaviour, typically childish and very picturesque which, as it has not as yet its own label in the repertory of psychological terms, we shall refer to simply as 'ambivalent reactions'.

In these reactions laughter and fear are closely intertwined. The child seems divided between two opposing affective tonalities, between anxiety and laughter, between depression and joking.

These reactions we divide into three categories, according to the way in which the laughter and fear were mingled: (1) hesitant, (2) oscillating, (3) contradictory. We hope soon to make a more thorough investigation of these mitigated reactions. With films we hope to make with the help of infra-red light, it will be possible to analyse at leisure the interference processes and the hesitations between laughter and fear.

For the moment it would appear that these ambivalent reactions, although relatively rare, are not individual anomalies but part of a normal growing-up stage through which most people pass. Statistical analysis of the data observed during the present experiments shows clearly that these reactions represent passing and transitory behaviour, corresponding to a level of maturity higher than fear behaviour, but lower than that of laughter or the open smile. In short, ambivalent reactions can be considered as intermediate threshold reactions. Under our research conditions they occurred most frequently in boys between 6 and 7 years of age and in girls between 8 and 9.

From the specific example given in Fig. 24, the process of transformation of fear into laughter and the appearance of ambivalent reactions can be studied.

It will be seen how the child, in growing up, progressively acquires the faculty of laughing at a mishap which he took seriously when he was a few years younger.

Fig. 24 does not refer to the whole test film, but to an extremely short scene, lasting about three seconds, in which the big ugly brute with the beard appears behind a curtain, just beside the sweet young girl to whom he wants to pay court.

At this point the behaviour of the children was of four different kinds:

- (1) Impassivity (real or apparent): there was no external or visible reaction that the observer could see; behaviour represented by the letter O.
- (2) Fear (or disquiet, anxiety, terror, sadness, and so on) represented by the letter P.
- (3) Ambivalent reactions where fear and laughter mingle represented by the letter A.
- (4) Laughter and smiles represented by the letter R.

The four diagrams shown in Fig. 24 each have four columns corresponding to one of these four types of behaviour. The first on the left represents impassivity, the second fear, the third ambivalent reactions, and the fourth open and nervous laughter. The number of spectators concerned is indicated above each column.

Each diagram accordingly shows the relative extent of each of the four types of behaviour in question.

With a view to making a genetic study, we distinguished four age groups and made four different diagrams: the first (upper left) for 4 years, the second (upper right) 5 and 6 years, the third (lower left) 7 and 8 years, the fourth (lower right) 9 to 14 years.

The successive changes with increasing age reflected in the four diagrams show clearly that a film sequence which is unquestionably funny to children over nine years of age can give rise to various types of fear reactions in children some years younger; the habit of laughter is only gradually acquired.

Fig. 25 is a second example, obtained from another very short sequence, of this criss-crossing of fear and laughter.

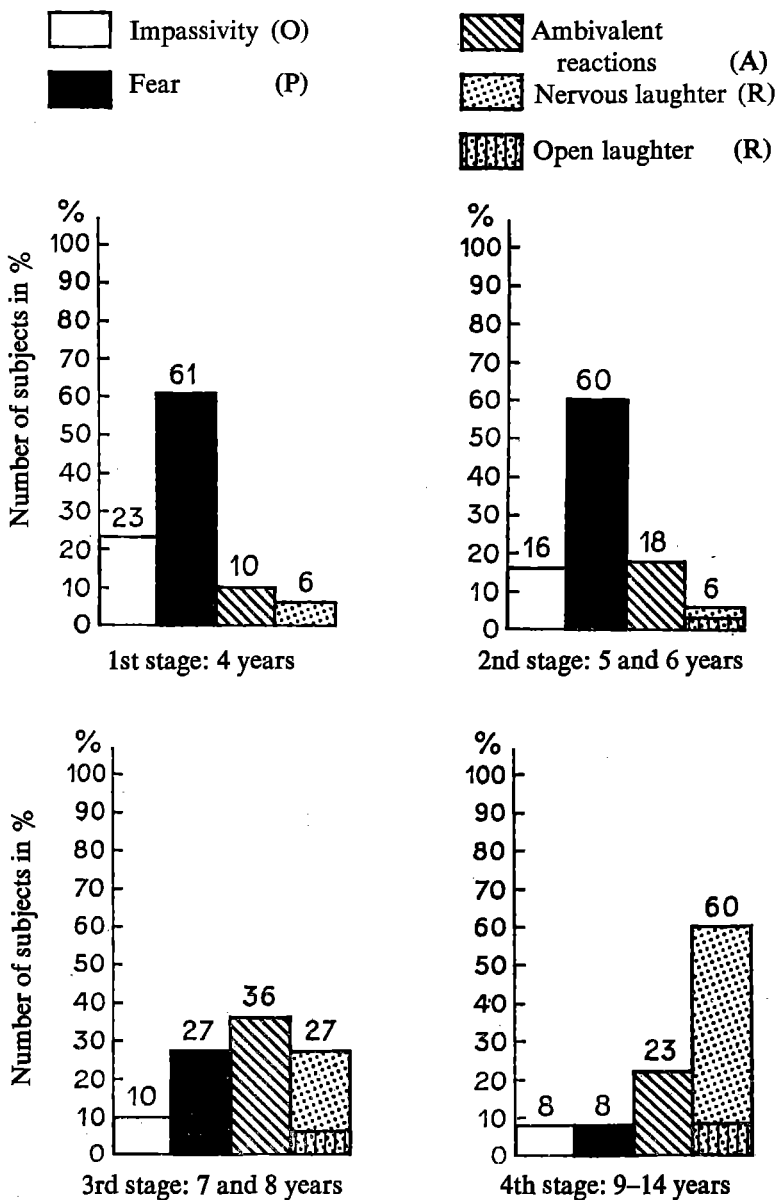

FIG. 24. THE TRANSFORMATION OF FEAR INTO LAUGHTER

First example: sequence No. 24. Appearance of the big brute.

The sequence is of Chaplin spinning like a top round the swimming-pool. Sent spinning by the swing doors of the hotel, he continues to spin round indefinitely like a top; still spinning, he goes up the stairs, arrives at the hotel swimming-pool, and falls in. The section used shows him arriving at the swimming-pool.

Here again it was found that the older the child, the less was fright or anxiety caused him or her by the scene.

This particular investigation of sequences which the older children found comic and which frightened the smallest (sequences involving a well-defined criss-crossing of fear and laughter) tends to indicate that laughter gets the upper hand as the child matures and that, genetically, this represents successive slidings, progressive shifts of the emotional dominants.

As he grows up, the child goes (a) from impassivity (indifference or affective neutrality), characteristic of the insufficiently developed individual, to fear and disquiet; (b) from fear and disquiet to mitigated reactions and nervous laughter; (c) from mitigated reactions and nervous laughter to open laughter, characteristic of the well-developed individual.

We have shown that the mitigated reactions reach maximum frequency at the cross-over point between fear and laughter (when laughs begin to exceed frights). This consequently is a threshold phenomenon.

Further experiment is, however, necessary; variation of the nature of the film stimuli will help to show how far it is possible to generalize this first descriptive outline, which is in the nature of a genetic demonstration of Max Eastman's thesis in which laughter is considered as a shock absorber.

SECOND SET OF RESULTS

A study of the reports on our experiments led us to take up a second problem—the structure of the child's emotional reactions. Since it is a purely psychological problem, well outside the problems teachers are really interested in, we shall merely mention it in passing.

Preliminary sampling led us to think that there might be changes in the way of expressing various emotions according to age and sex, changes as between infant and child, and between boy and girl.

During the experiment proper, accordingly, we tried a differential study, by age and sex, of some motor manifestations of the body and limbs, of certain gestures and attitudes accompanying the onset of emotions.

As we consider this differential study particularly interesting, we intend to go more thoroughly and carefully into it when we have the infra-red film technique available; by this means we shall be able to analyse more conveniently than by direct clinical observation functional behaviour patterns in young spectators.

As our research has clearly shown, it is in fact possible to

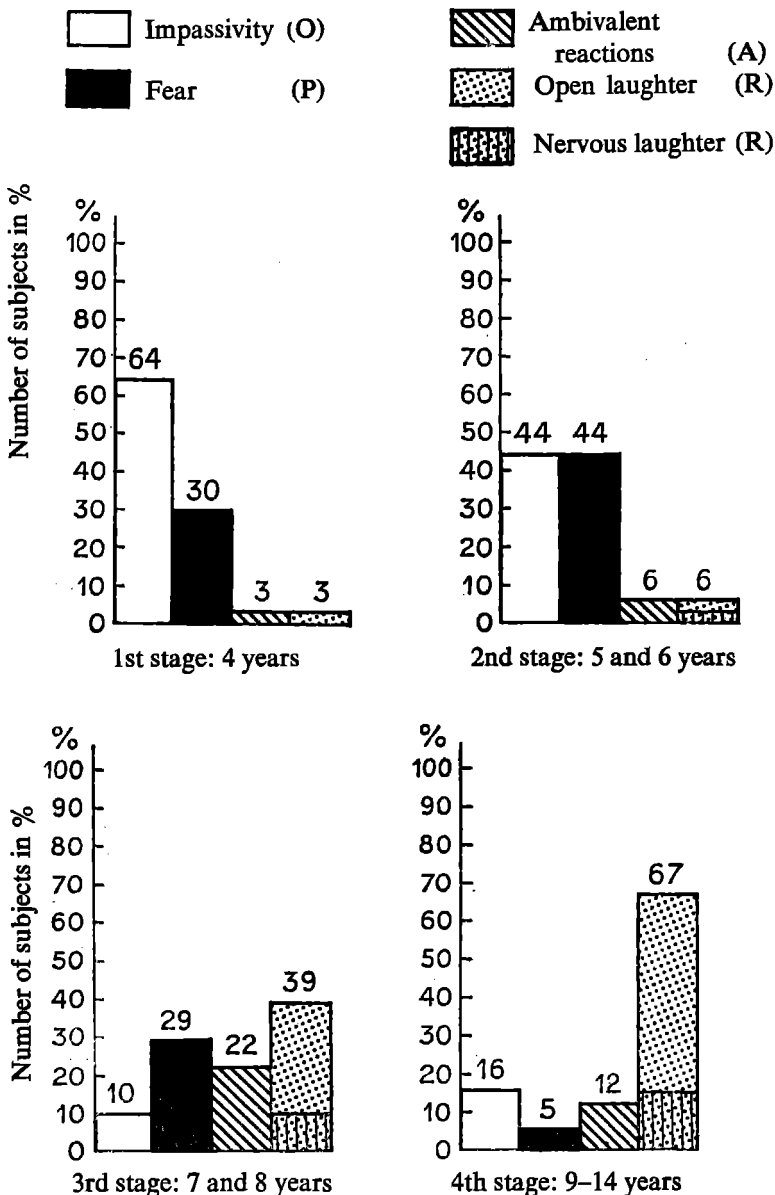

FIG. 25. THE TRANSFORMATION OF FEAR INTO LAUGHTER

Third example: sequence No. 73. Charlie, still spinning, falls into the pool.

introduce statistics into the genetic study of various motor expressions that accompany the onset of emotions.

During this pilot experiment we have already succeeded in obtaining age curves which tend to show that certain gestures and certain attitudes appear preferentially in children who are younger or in children who are older.

From the same point of view, we have demonstrated important differences between boys and girls. Some motor expressions are preferentially masculine, others preferentially feminine (e.g., masculine motor expressions: series of bounds, unco-ordinated gesticulations, rhythmical rocking of the body forward and backward, slapping themselves or their neighbours; feminine motor expressions: covering up the mouth when laughing, muscular contractions of the body, cries, protective movements).

Analysing the preferred masculine motor manifestations and comparing them with one another, and doing similarly for the preferred feminine manifestations, we were led to formulate the following hypothesis to serve in the investigations following. In boys, raising of the tension underlying the emotion will express itself rather in the form of motor agitation and by movements which affect the sense of balance, whereas in girls, this tension will display itself rather in the form of spasms and motor rigidity, and be accompanied by nociceptive (hurting oneself) movements, movements implying a retreat into oneself and a return to peripheral sensitivity (cf., Wallon).

Fig. 26 gives four age-group examples: (a) unco-ordinated movements of arms or legs; (b) small consecutive jumps or bounces on the seat; (c) noise accompaniments such as "bang", "wham", and so on; (d) rocking backward and forward with laughter.

The age range is given along the abscissa and the average number of displays of the motor phenomena along the ordinate. The unbroken curve represents the boys, the broken curve the girls. It will be seen that the motor manifestations are preferentially masculine.

Fig. 27 gives four examples of age curves for preferred feminine motor manifestations: (a) biting the nails; (b) covering the eyes; (c) hiding the mouth with the hands; (d) shrinking movements.

This very revealing study on the psychology of emotional expression in children is being continued.

THIRD SET OF RESULTS

A third series of results is centred on group activities displayed in a cinema full of young children.

At the cinema the child is not alone: he is a member of the audience, sitting next to more or less immediate neighbours. He is not always exclusively concerned with the moving figures on the screen. From time to time he will detach himself from the film and resume contact with his comrades, ask questions, make them

Unco-ordinated movements, etc.

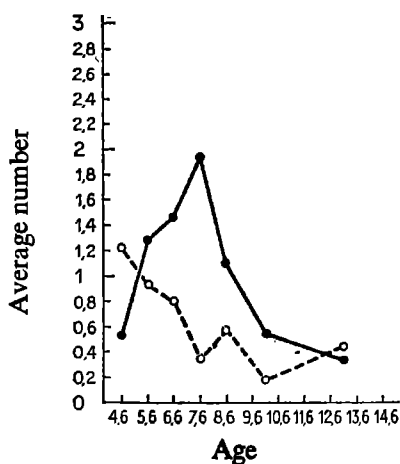

Little jumps

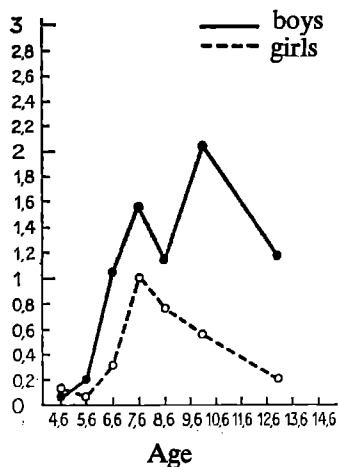

Noise accompaniments such as "bang", "wham"

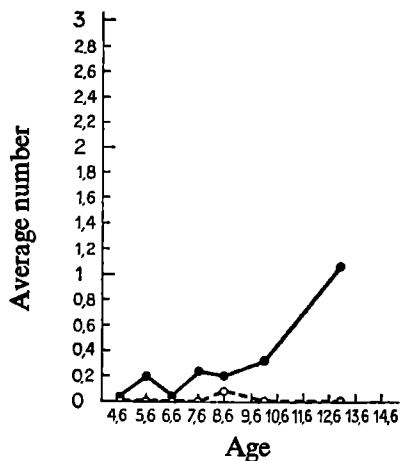

Rocking backward and forward with laughter

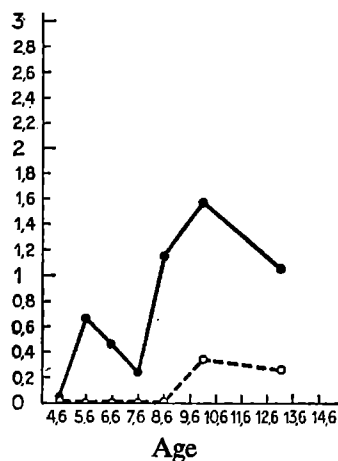
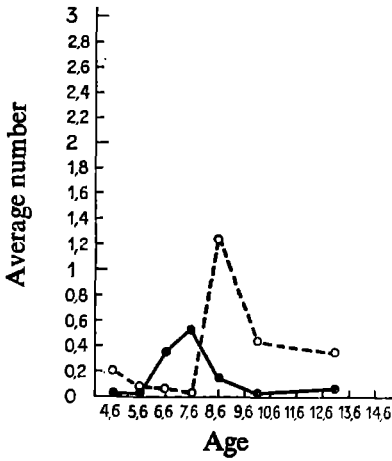
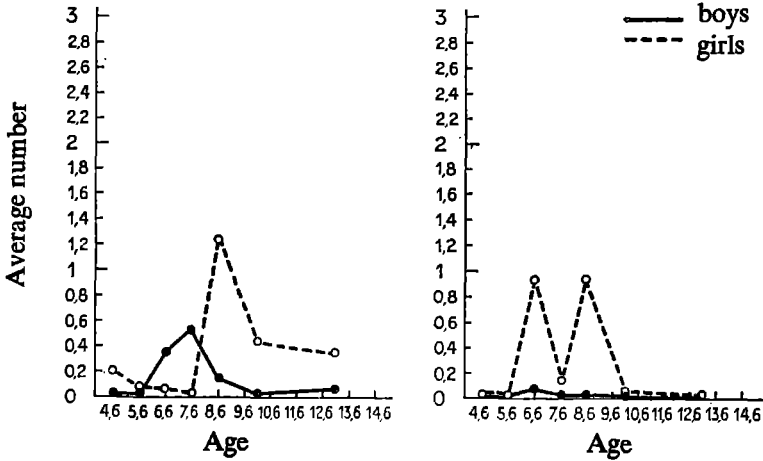

FIG. 26. MASCULINE MOTOR MANIFESTATIONS

Biting the nails



Covering the eyes



Hiding the mouth with the hands (laughter) touching the lips

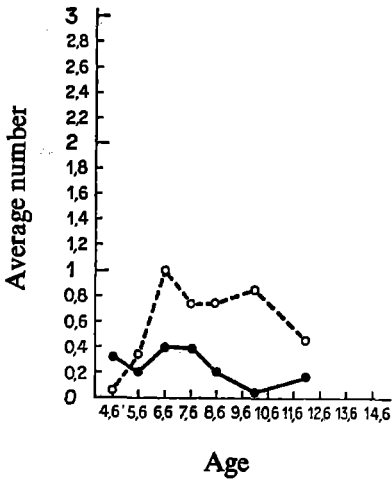

Shrinking movements

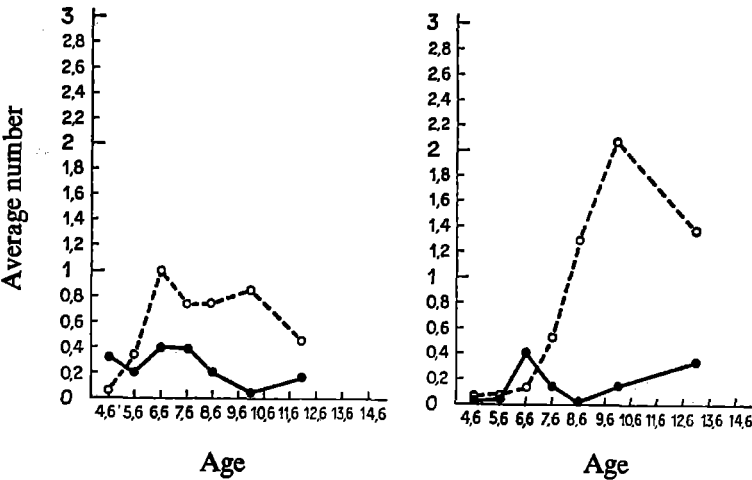

FIG. 27. FEMININE MOTOR MANIFESTATIONS

laugh, ask for confirmation, request explanations, try to reassure himself, or share his own emotion with them.

Statistical analysis of the data relating to such contacts observed during our experiment yields the following results:

1. Contacts between the children were relatively rare; the very young child at the cinema remains an apparently isolated individual, concentrating on the screen. From time to time, however, and particularly when he laughs or is frightened, he resumes contact with those around him.

2. Such contacts during outbreaks of emotion become more numerous as the children become older (doubling between 4 and 11 years of age).

3. Very clear qualitative modifications also appear with the increase in age.

(a) First, the mode of expression utilized in order to enter into contact with someone else tends to change (Fig. 28). We distinguished three modes—speech, look, and gesture—and calculated their relative importance. Three age groups were studied: 4 and 5, 6 and 7, 8 to 14 years. It will be seen that the change with increasing age is from a look to speech.

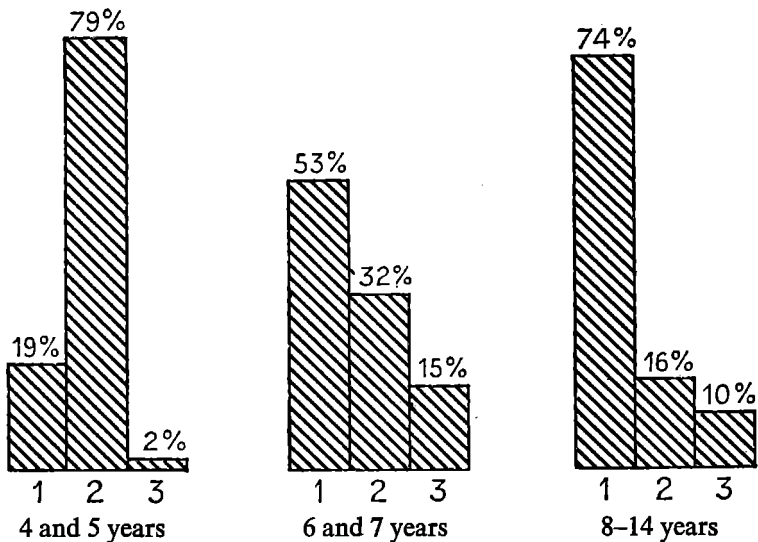

FIG. 28. CONTACTS BETWEEN CHILD SPECTATORS

Mode of expression for entering into contact (variations with age).

1. Speech; 2. Look; 3. Gesture.

(b) We were interested, secondly, in the person with whom contact was made—the immediate neighbour, the teacher, or the audience in general. Fig. 29 shows that in growing up the child addresses himself more and more to his immediate neighbour, less and less to the teacher and the audience as a whole.

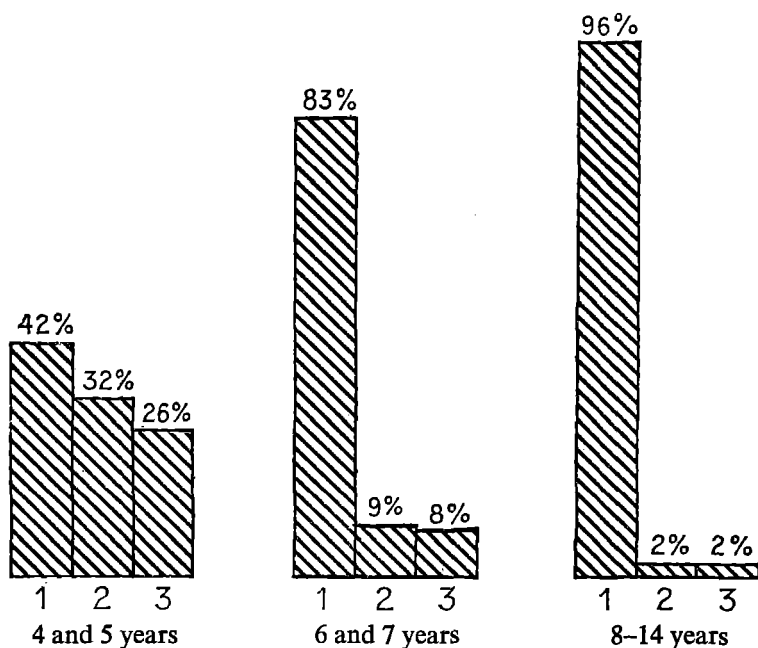

FIG. 29. CONTACT BETWEEN CHILD SPECTATORS

Persons with whom the spectator enters into contact (variations with age).

1. Neighbour; 2. Audience; 3. Teacher.

(c) We also studied the underlying tension when contact with someone else is sought. The analysis of the data observed revealed four main types of tension: stimulation (wanting someone else to react with the same intensity of emotion); union (feeling the same emotion as someone else at the same level of intensity, being moved with someone else at the same time, sharing the emotion); acquiescence (allowing oneself to be stimulated by another, placing oneself on the same emotional level as another); disagreement (rejecting the other person's emotion, belittling it, refusing to share it, or being surprised at it). Fig. 30 shows how the attitudes

change with age: as the child grows older he moves from passive acquiescence to active stimulation.

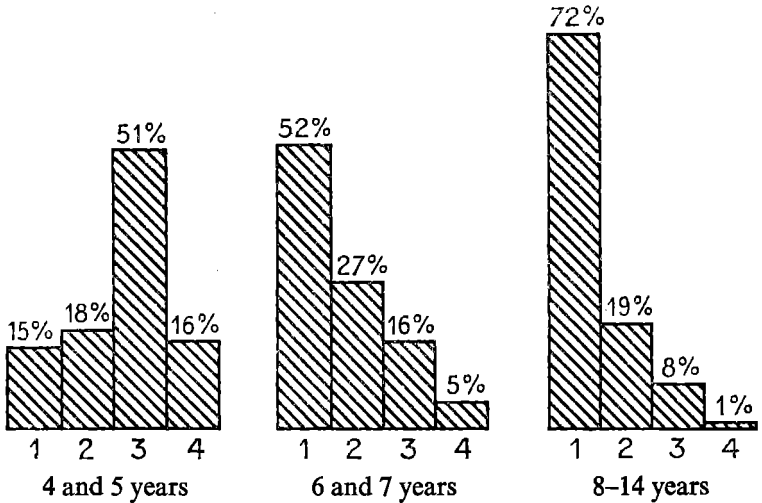

FIG. 30. CONTACTS BETWEEN CHILD SPECTATORS

Attitude of spectator seeking the contact (variations with age).

1. Stimulation; 2. Union; 3. Acquiescence—imitation; 4. Disagreement.

Curiously enough from the social psychological point of view, we found no appreciable difference between the groups of boys and the groups of girls.

Studies of this kind can be helpful to teachers and those responsible for arranging shows for children, allowing them to take account of important emotional differences that are related to the age and sex of the children. We have seen that there is not 'a' child audience, as people are too inclined to believe, but child audiences having very different reactions, since, as we have observed, an age interval of two or three years can bring about great changes and even a complete reversal of affective attitudes involved.

In order that we may understand these problems better, we should ensure that there is nothing that will cause defence and anxiety reactions, piercing cries of fear, and the anxious stamping too often seen in audiences composed of very young children who may even be watching a film meant to amuse them: similarly, with children a little older, belittling or contemptuous comment on the film should be avoided.

We must learn—and this is important, because, to children, laughter is a need—how to make comic films that are really

acceptable to children of school and pre-school age. It is not, as is usually done, through producing allegedly comic films that are inferior intellectually and aesthetically, or using poor gags from the most stupid, and often even the most coarse, films for adults that children can be most surely made to laugh. The child's laughter is usually other than that of the adult, but it is not necessarily something inferior.

Children will laugh with free, open, and healthy laughter at television and at films when producers succeed in producing films measuring up to the special humour of children, films that take account of their inexperience and, above all, of their affective vulnerability.

In the work of Mme A. Leroy-Boussion we touch upon all the research that has been done on the behaviour of children during the projection of films. Another, and a model, example to quote is the international competition for recreational films, organized on the technical side by R. Zazzo.

THE EXPERIMENTAL DESIGN

During the international competition for films for children steps were taken to secure an explanation of children's voting and an analysis of their reactions to films, and after each showing, they were asked about their preferences.

The investigation was made in the following stages:

- (a) Before projection each film was divided into sections, and each section was timed. This provided reference points. A Morse key and electric contact marked on a tape, on which the children's reactions were recorded, the corresponding reference point on the film.
- (b) During projection the children's reactions were automatically recorded or described by observers who used various machines and techniques—decibel metre, press buttons which allowed three observers to note the children's reactions in accordance with a pre-prepared code, written comments by specially trained observers, recording of the comments and verbal reactions of the children, and ultra-violet photography.
- (c) Immediately after projection the children voted, children selected at random were individually interviewed, and there was a vote and evaluation by the adults (the teachers who accompanied the children to the film shows).

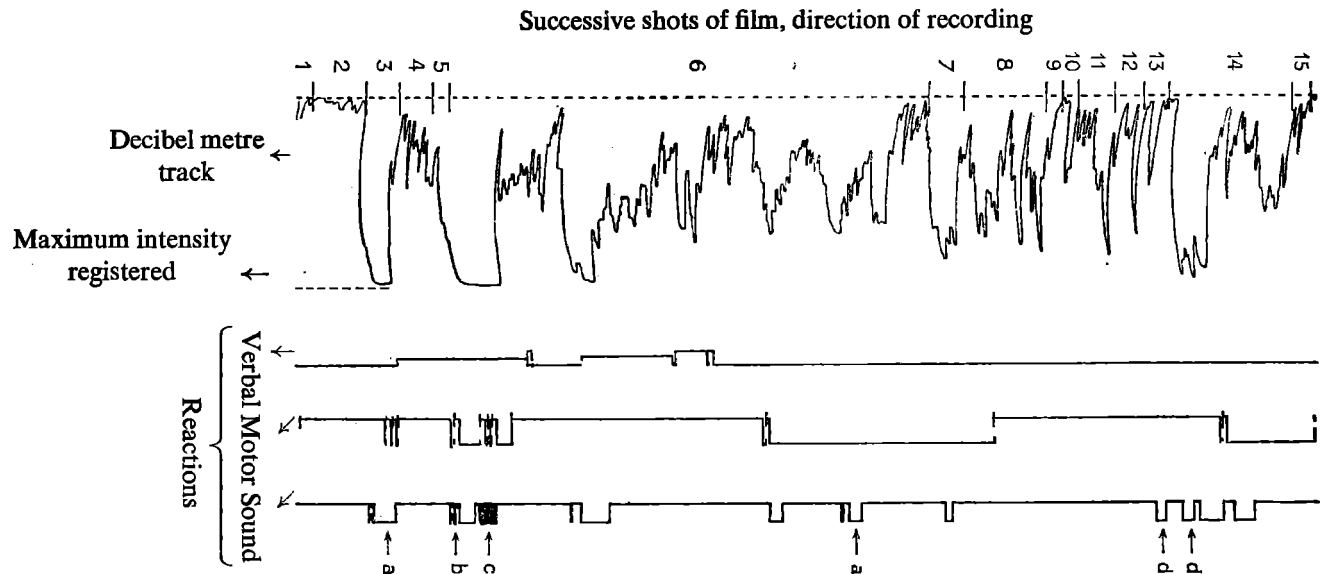

Successive shots of film. 1. End of distant shot of Folco mounted on Crin Blanc. 2. Folco strokes Crin Blanc and catches sight of the rabbit (closer shot). 3. Close-up of rabbit. 4. Folco gallops on Crin Blanc. 5. The rabbit runs. 6. Distant shot of Folco on Crin Blanc pursuing the rabbit. 7. Close-up shot of the rabbit between Crin Blanc's hooves. 8. The rabbit (seen from afar) rejoined by Folco and Crin Blanc. 9. Folco gallops on Crin Blanc. 10. The rabbit runs. 11. Distant shot of Folco, Crin Blanc, and the rabbit. Folco turns around the rabbit. 12. Closer shot: Folco on Crin Blanc looks at the rabbit and turns round. 13. Close-up of the rabbit between the hooves of Crin Blanc. 14. The rabbit starts off, Folco following, then stops. 15. Close-up of the rabbit.

Sound reaction code track. a. General laughter. b. Generalized cries. c. Laughter and cries. d. Scattered laughter.

(Extract from the *Courrier du Centre International de l'Enfance* (*Courrier*, Nos. 4-5, 1954, pp. 247-255))

FIG. 31. FACSIMILE OF A RECORDING SHEET

First Age Group (7 to 9 years)

Girls

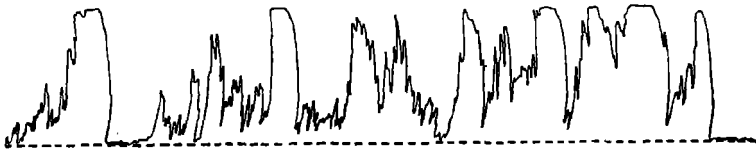

Boys

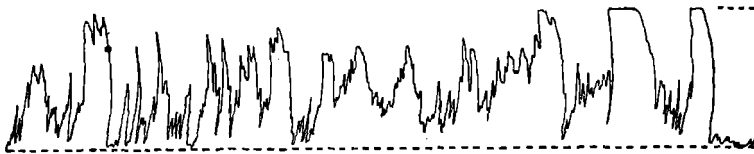

Second Age Group (10 to 12 years)

Girls

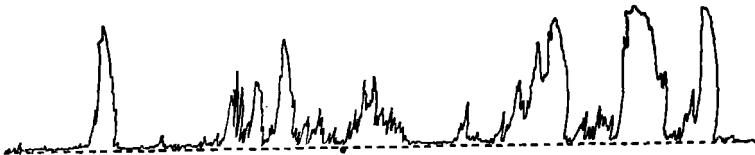

Boys

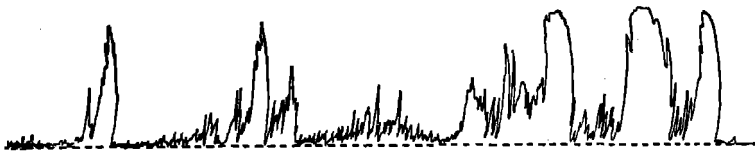

FIG. 32. DECIBEL COMPARISON OF REACTIONS OF FOUR GROUPS OF CHILDREN AT THE SAME SEQUENCE OF "CRIN BLANC"

Beginning of the pursuit sequence, given shot by shot in Fig. 31. The four recordings are exactly co-ordinated. It will be noted that the reactions in each of the four groups of children start simultaneously; here age differences count for much more than differences of sex.

- (d) Delayed reactions were investigated by means of a vote taken in the classroom a week after the projection, and, at the teacher's choice, in one of the following three ways—vote proper, vote and retelling of the story, vote by drawing (. . . “draw what you would like to see again”). Sampling questionnaires relating to the films as a whole were also used.

The amount of information so obtained can easily be imagined. We shall give a brief summary here of the general results (a fuller analysis is in preparation).

1. Technical cutting and the children's vote: “Other things being equal, cutting in the films the girls liked best was slower than in those preferred by the boys, and this irrespective of age.” The speed of cutting is measured by the average duration of the shots. The figures for the ten first films shown to each of the four groups of children were:

	<i>Elementary Classes</i>	<i>Intermediate Classes</i>
Girls . . .	7.2 seconds	8.2 seconds
Boys . . .	6.6 seconds	6.9 seconds

This value is obviously not definitive, and the authors rightly point out that it is not only the average duration of the shots which matters; account has also to be taken of montage, the more or less greater mobility of the camera, the speed of the story-telling, the affective tonality, etc.

2. For the first age group (7 to 9 years) the teacher's choice of films best suited to the appropriate scholastic programme more or less coincides with the choice of the children themselves, girls and boys. This is not true for the second age group (9 to 11 years), except for absolutely first-class films. This can be shown in tabular form (see Table 8).

TABLE 8. NUMBER OF AGREEMENTS AND DISAGREEMENTS BETWEEN TEACHERS AND PUPILS

	BOYS		GIRLS	
	<i>Agreement</i>	<i>Disagreement</i>	<i>Agreement</i>	<i>Disagreement</i>
First age group	9	2	10	1
Second age group	7	6+ 1 doubtful	8	5+ 1 doubtful

From a detailed study of the choices made from amongst the different films, the authors conclude: "This comparison reveals that, on the whole, children chose what their teachers would have selected for them but that the analysis more accurately indicated the differences of choice by sex and age than the teachers could have done on their own."

3. Reactions during the projection and the votes. A first analysis, relating to the youngest children, of the results graphically recorded during the projection indicates that the children's vote could be predicted with only a very small margin of error from their reactions during the showing. The three observers were supplied with equipment for measuring reactions under three headings—sound, motor, and verbal behaviour. Table 9 below summarizes the results.

TABLE 9

<i>Indices</i>	<i>Motor</i>	<i>Verbal</i>	<i>Sound</i>
a ¹	audience agitation	conversation chatting	
b ¹	agitation; partial participation in sympathy with the film; scattered applause	conversations relating to the screen; comments, isolated interjections	scattered laughter, scattered cries
d ²	agitation; general audience participa- tion; general applause	generalized comment; generalized interjections	generalized laughter; generalized cries; generalized laughter and cries
c ²	immobility	complete silence	

From the estimated relative extent of these different types of behaviour profiles of the reactions observed were constructed. They are given in Fig. 33 for the two films shown in the same programme—*Tchouk et Guek, Seul au Monde*.

¹ Not majority reactions.

² Majority reactions.

Film: *Seul au monde*

Girls (intermediate). Same audience for both films

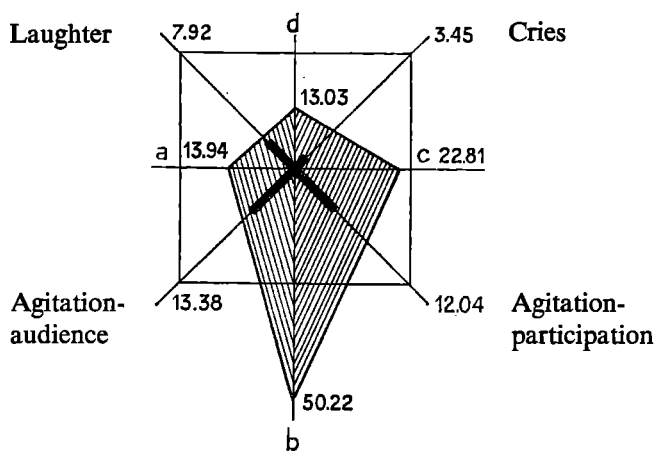

Boys (intermediate). Same audience for both films

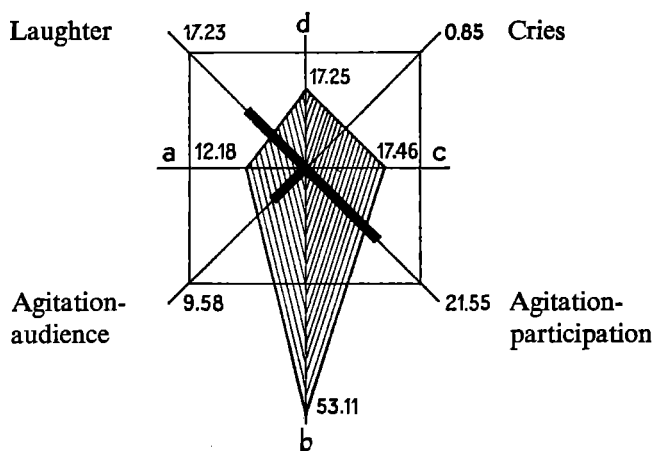

Films: *Tchouk et Guek*

Girls (intermediate). Same audience for both films

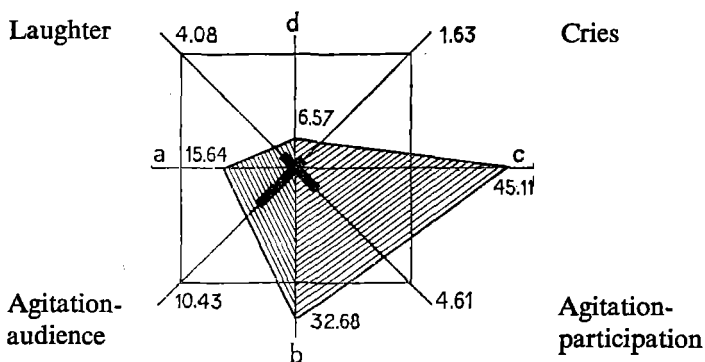

Boys (intermediate). Same audience for both films

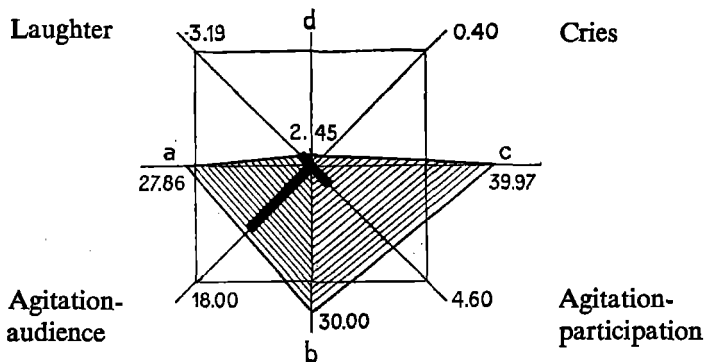

FIG. 33. REACTION DIAGRAMS FOR TWO FILMS ON THE SAME PROGRAMME

(For both sexes the preferred film was *Tchouk et Guek*.) The form of the diagram depends more on the film itself than on the nature of the public (girls or boys). There was more c (silence-immobility) during the preferred film than during the other, and more with the girls (who gave it first prize) than with the boys.

The main axes carry the four indices a, b, c, and d. A quadrilateral figure is obtained by joining the four extremities. Some of the more particularly interesting items of behaviour are indicated along the diagonal lines (also as a percentage of the total time)—laughter (scattered and generalized), cries (scattered and generalized), agitation-participation (scattered or generalized), agitation in the audience (audience hostility).

Despite the empirical nature of these evaluations, referred to by the authors of this remarkable investigation, they note a close relationship, at least amongst the elementary school children, between the reactions and the vote—*i.e.*, an inverse relation between index a (chatting, agitation in the audience) and the vote; a direct relationship between index c (silence, immobility) and the vote. Moreover, by combining these two indices, subtracting index a from index c, a new index (c-a) is obtained which, as will be seen from the table below, is still more closely related to the vote.

TABLE 10

	-a	c	c-a
Elementary class	12/17	11/17	15/17
Intermediate class	14/22	13/22	15/22

The denominators 17 and 22 give the number of pairs of films in respect of which the comparison was established.

Much could be said from the point of view of differential psychology about these results, but, as space is lacking, we must keep to general conclusions which directly concern our own study.

1. Duration. Films which are too long or too short do not suit children; reactions weaken after a time, and films which are too short disappoint them. The commercial film formula (about 80 to 100 minutes) implies a story presentation which does not suit a child public: the introduction to the action is usually too complicated, and the main line of action is inclined to get lost in the secondary actions. About 40 minutes would appear to be the optimum duration.
2. Laughter may represent either sympathy or, on the contrary, hostility. It may be the response to very different stimuli and represent very different feelings in the

- spectator: a reaction to the comic aspect of situations and of people, or the expression of satisfaction, good humour, or hyper-excitement.
3. Other things being equal, children will prefer not the films which excite them most but those which most imperatively command their attention or their emotions.
 4. Concerning films which introduce fairy-tales, marvels, and dreams the authors say that children find it hard to comprehend, on the screen, the transfer from reality to dream.

II. COMPREHENSION

Our usual habits of thought and conventional teaching traditions would suggest that the study of comprehension should have a vital place in a book on the educational psychology of audio-visual aids in the primary school. So thoroughly do we share this view that we feel a book could be devoted to the subject, to the research already undertaken, and to various psychological and educational conclusions which have a direct bearing on school practice. To keep within the limits of this study, and remembering the remarks made at the beginning of this chapter, we shall cite certain research and try to draw conclusions sufficiently general to facilitate further experiment.

THE UNDERSTANDING OF STATIONARY IMAGES

We shall not deal here with studies done on the perception and comprehension of images by psychologists who use them in intelligence tests (Binet-Simon at the beginning of the century), but take up the subject from the angle of the comprehension of a filmstrip used in certain methods for learning foreign languages.

With a view to evaluating the psychological content imparted by filmstrips which tell a story, the following experiment was made (159 and 160). Three filmstrips having stories which would interest children and had psychological unity were selected from the CREDIF audio-visual method for learning French. Their stories can be summarized as follows:

Film 1. *The Story of the Ball*. (11 frames; two characters: the park attendant and a child.) An attendant scolds a child he finds on a lawn where he should not be. The child explains that a ball rolled

on to the grass, and he wanted to get it back. The attendant tells him not to walk on the grass again.

Film 2. *The Story of the Boat*. (8 frames; 3 characters: the attendant and two children.) Two children are playing with a boat beside a pond. The boat gets too far away, and the children try to get it back with a stick. An attendant arrives. He is afraid the children will fall into the water, takes the stick, and gets back the boat. The children thank him.

Film 3. *The Blow with a Spade*. (8 frames; 3 characters: the park attendant and two children.) An attendant comforts a child who is crying and who says another child has hit him with a spade. The second child denies this and accuses the first of having started the row. The attendant reflects and settles the dispute.

The experiment involved 212 children, of both sexes, in French primary schools (first and second year elementary, first and second year intermediate—*i.e.*, from 7 to 11 years). The articles indicated in the bibliography (157–161) provide full details of the sampling and the planning of the experiment.

The children were twice shown the visual strip alone. They related what they saw. Then they were shown the strip again, commenting this time on the frames one by one. The replies were recorded fully, and carefully scrutinized so that a detailed analysis could be made of their reactions.

A brief study of the information collected during the two first showings is interesting from the angle of genetic development and of the material used. Here 'information' is being used to mean the number of different ideas expressed in their retelling; the following table shows the average obtained:

TABLE 11

	<i>Elementary</i>		<i>Intermediate</i>		<i>Average</i>
	1	2	1	2	
Film 1	5.2	4.9	5.2	5.8	5.27
Film 2	5.3	6	6.8	5.8	5.9
Film 3	3.6	3.9	5.2	7	4.9
Average	4.7	4.9	5.4	6.5	5.3

It will be seen immediately that the reaction to the same material obviously becomes more elaborate with age, but the material

itself introduces a source of variation which must not be overlooked. The length of the description increases with age, but not uniformly. Film 3, the film least understood in the 7 to 8 age group, became the best understood at 10 to 11 years. The sudden advance at the age of 10 seems to signify a period of rapid development.

In order to obtain a better idea of the psychological forms of their comprehension, this summary quantitative analysis was supplemented by a qualitative study of the types of the children's versions.

Taking Binet's three classical categories, we sorted the versions into enumerations, descriptions, and interpretations. The results are interesting for the educational conclusions that can be drawn from them. The following table was obtained by expressing the results in terms of percentages of the total number of replies recorded:

TABLE 12

Type	<i>Elementary</i>		<i>Intermediate</i>	
	1 7-8 years	2 8-9 years	1 9-10 years	2 10-11 years
1. Enumeration	25.3	4.5	2.56	0.5
2. Description	23.5	31.1	25.4	15.6
3. Interpretation	51.1	64.1	71.9	83.7

This can easily be represented graphically as shown in Fig. 34.

These results are close to those obtained by Osterrieth in his test involving the copying of a complicated figure (169). From the age of 7 at least 50 per cent of the children 'interpret' the filmstrips and, after the peak of 'description' at about 8 years of age, 'description' and 'enumeration' diminish regularly. However, the percentage of 'interpretations' has not reached as much as 75 at the age of 9, and this raises important problems as far as the educational utilization of the results is concerned.

The results must also be carefully considered in relation to the filmstrips themselves. The difficulties introduced by the material used are too often overlooked. As Table 13 shows, account must be taken of this factor; if not, the bald statements may be contradicted by the facts.

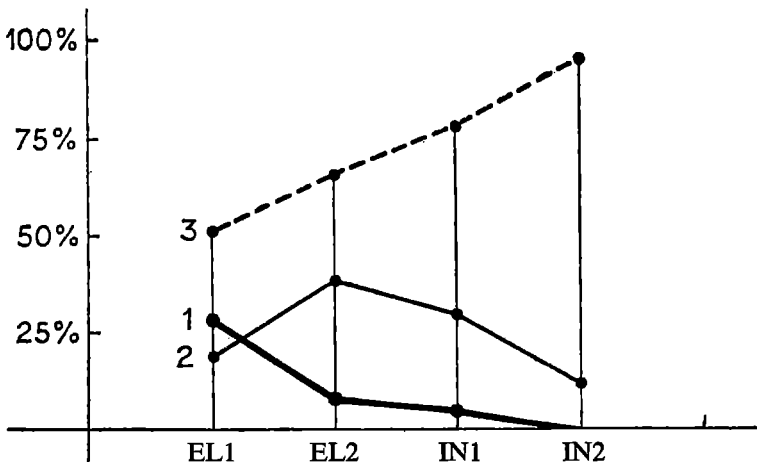

FIG. 34. GRAPH OF TABLE 12

1. Enumeration 2. Description 3. Interpretation

These results really require a great deal of comment, but we shall merely point out that the psychological reaction would seem to be clearly related to the structure of the visual document; when the intrinsic difficulty of understanding them is the same, films may be made more easy or more difficult to understand by their style and form. Before any film is used for teaching purposes its relative 'difficulty' should be determined so that the best teaching methods for making use of it can be employed.

Hitherto we have spoken of 'interpretation' only as a category. Does this interpretation correspond to what the maker of the film intended? To put it bluntly, so far as the intention of the adult is concerned, has the child correctly understood the story told visually? It is difficult to give a clear-cut answer because several cases must be considered, and four types of response distinguished:

- (a) Correct synthesis: the child has got the essential points of the story.
- (b) Incomplete synthesis: he has understood only part of the story.
- (c) False synthesis: his description is coherent but not what the maker of the film intended.

(d) No synthesis: he relates what he has remembered without establishing any logical connection between the various parts.

TABLE 13

TYPE	CLASS	FILM 1	FILM 2	FILM 3	AVERAGE
Enumeration	EL 1	25.6	13.3	37	25.3
	EL 2	2.15	4.4	7.2	4.5
	IN 1	0	1.7	6	2.56
	IN 2	0	0	1.5	0.5
	Average	6.9	4.8	12.9	
Description	EL 1	24.3	24	22.2	23.5
	EL 2	27.9	25.5	40	31.1
	IN 1	25	22.4	29	25.4
	IN 2	12.5	17.3	17.2	15.6
	Average	22.4	22.3	27.1	
Interpretation	EL 1	50	62.6	40.7	51.1
	EL 2	69.8	70	52.7	64.1
	IN 1	75	75.8	65	71.9
	IN 2	87.5	82.6	81.2	83.7
	Average	70.5	72.7	59.9	

IN 1 = Intermediate 1 (9-10 years); IN 2 = Intermediate 2 (10-11 years)

EL 1 = Elementary 1 (7-8 years); EL 2 = Elementary 2 (8-9 years)

We shall consider only the following main points from the authors' general table.

TABLE 14

SYNTHESIS	EL 1 7-8 years	EL 2 8-9 years	IN 1 9-10 years	IN 2 10-11 years
Correct	4.4	13.1	25.8	54.8
Incomplete	24.7	40	32.8	29.4
False	20.7	18.7	20.7	15.5
None	49.9	27.9	20.4	0

(As before, the results are expressed in percentages.)

It will be noted that full comprehension (*i.e.*, a correct interpretation) was obtained in only 54 per cent of cases in the 10 to 11 age group. The visual documents were filmstrips—*i.e.*, documents devoid of movement and life. Moreover, only the visual strip was available, and the results would certainly have been very different if there had also been a sound track.

This experiment enabled the authors to study another problem that is akin to the problem raised by cartoon strips in the newspapers. To represent certain aspects of a situation, 'balloons' were used to represent a person or object corresponding to the dialogue or the thoughts of one of the characters concerned. We shall see later how it is possible to study the rôle played by style in films; here we are concerned solely with the graphic style of the drawing. In the results given below we have considered the child's understanding of the 'balloon' satisfactory when in a certain frame he was able to identify the character represented in the 'balloon' with that in the frame (despite differences in colour) and when his response showed that he understood that two different actions in time were involved. The percentage of correct results clearly varies with age and very appreciably increases from 8 years onward.

TABLE 15

	EL 1	EL 2	IN 1	IN 2
	7-8 years	8-9 years	9-10 years	10-11 years
Average per cent	39.6	66.7	77.2	95.9

It can confidently be said that, from the age of 9 to 10 years, certain graphic conventions are perfectly well understood by children.

Examining the educational aspects, it will be especially noted that a filmstrip is not automatically a help for a child unless he has reached a certain level of psychological maturity. Audio-visual techniques are not an educational panacea for all problems; they can often help, but in other cases encounter the difficulties common to any teaching situation.

Before finishing with this point we should also point out that the successive presentation of images involves a special difficulty which the investigator must study. A situation which is complicated but has a unity of its own is divided up, and the child is then required to

readjust the sections—the technique itself creates a problem which does not exist in real life. This question has been studied in works not yet published. Here, for instance, are some results obtained by C. Malandain in this field. Instead of presenting the frames of a film successively, he projected them in three groups, corresponding to different moments of the action. Initially eleven successive images were shown, and then the frames were grouped into three sections as follows:

1	2
3	4

5	9	6
7	8	

10	11

An analysis similar to the one described earlier gave the following table, which, so far as the increase in the rate of comprehension is concerned, needs no comment. (Results are given for two classes only.)

TABLE 16

SYNTHESIS	IN 1 9-10 years		IN 2 10-11 years	
	filmstrip per cent	grouped images per cent	filmstrip per cent	grouped images per cent
Correct	21	40	27.2	41.5
Incomplete	57.8	26.6	45.4	41.5
False	10.5	20	27.2	17
None	10.5	13		

Hence the whole question of determining, as objectively as possible, the best way of utilizing audio-visual material remains wide open to educational experiment; and without fear of contradiction it can be said that research is scanty in this field.

THE COMPREHENSION OF FILMS

Before taking up the important question of the comprehension of the animated film, we shall deal with a problem of form—*i.e.*, cinematographic language.

The child's understanding of cinematographic language

The above results for filmstrips indicate that certain difficulties not only depend on content, but are also affected by the manner of its representation. Many of the otherwise valuable investigations carried out were made with existing films which could not be

changed either in content or in structure. We therefore completely designed and made three films for the special purpose of varying one or other of the factors which we believed influenced the intelligibility of the film for the child (161).

As our educational objectives were very well-defined and essentially practical, we concentrated on intelligibility criteria in planning this first phase of a long investigation. We are naturally not neglecting the rôle of affectivity in the teaching film—on the contrary—but we are deferring it to another investigation.

Presentation of three films

Our aim in writing the scenarios and in the still more difficult and important question of cutting was to make three films of the same length (6½–7 minutes) on the same subject, but by three completely different techniques—*i.e.*, to tell the same story in three different cinematographic ‘languages’. The first difficulty was to choose the subject.

Although we wanted a teaching film, it did not seem necessary to choose a school subject since, in this first experiment, it was form which was most important. We wanted a subject that could be treated in three different ways without this seeming too artificial—possible with a purely fictional film, but not so easy with a teaching film.

We chose a simple action that could easily be told in a few sentences; it had logical continuity, a certain dramatic progression, and a happy ending.

We also wanted something that would please children, and, having experiments previous to ours in mind, thought we would best succeed by putting a child in the film.

The following is a synopsis of the three films:

Night. Full moon. A little girl, sleeping, alone in her room, awakes, gets up, and goes to get a candle she has hidden in her box of toys. She lights the candle, goes through the sleeping house, mounts to the attic, finds, in a trunk, a ballet dress and shoes. She puts them on and begins to dance. Her mother hears and comes up. While dancing the child knocks over a large vase from a sideboard. The mother intervenes, puts her ordinary clothes on again, brings her back to her room, and puts her to bed. The little girl falls asleep, pressing to her heart the rose she had worn on the ballet dress.

The three films had a common first part and an identical ending:

<i>Part common to the three films</i>	<i>Experimental part</i>	<i>Part common to the three films</i>
Beginning	Film A Film B Film C	End

The child has to enter into the atmosphere of the film and be allowed a few moments to adapt. The importance of emotive phenomena, especially in young children, is such that the phenomena of comprehension can get completely confused in this short preliminary period during which the children are not yet concentrating. Roughly speaking, it will be agreed that, irrespective of the form of presentation, the children had all had the same conditioning when they came to the specifically experimental part of the film.

Again, the first and last sequences are so important for fixation that we decided to give all three films an absolutely identical ending. All the children accordingly became non-spectators again under the same conditions, since the last scenes introduce the same factor in the structure of the tale as a whole.

The tale had three different cuttings. The shots were worked out as follows:

- (a) In the first film all the shots were general. All the characters concerned are constantly in sight and unequivocally located in relation to the various parts of the scene. Their action is continuously followed by the camera; there is no ellipsis, no cutting into shots, no attempt to impose a rhythm. The 'cinema time' coincides exactly and at all times with the time the action would really take. This version, technically the simplest, has only 18 shots each of an average duration of 17 seconds in its experimental part.
- (b) The main new features of the second version were: changes of scale (general shot, close-up, and extra close-up), field/reverse field, simple parallel montage, and a rhythm much more varied than in the first version, where all the shots lasted about the same length.

The second version also twice uses symbolism or allusion. The child is shown dressing up by the play of

shadows on the wall; when she takes off the ballet dress she is out of range of the camera, and the spectator only sees the skirt and shoes falling on the pieces of the vase she has broken.

In its experimental part this version had twice as many shots (36) as the first, their average duration being about 8 seconds.

- (c) In the third version any cinematographic language device which seemed necessary was used. Time was not rigidly chronological; twice the classical time device of the lap-dissolve shot was employed. We made plenty of use of the subjective camera technique and broke up the film space in which the characters appeared as much as possible. This time the experimental part of the film had 51 shots, of an average duration of 5 seconds.

An extract from the shooting scripts of the three films will give a better idea of these differences.

The girl, after finding the ballet skirt in the trunk, finds the little satin shoes, and dresses up as a dancer.

Film A

1. (Medium shot.) At the end of this shot the girl, seen three-quarter face, takes the dancing shoes out of the trunk. She makes them do a little dance of their own, and then puts them back, gets up and passes behind the raised lid of the trunk in order to change.

2. (Distant shot.) The camera takes in the open trunk, the stool on which the candle is placed, and the back of the garret. The girl, first hidden by the lid of the trunk, gets up. She has taken off the coat of her pyjamas. She puts on the ballet skirt (only the upper part of her body is visible), then disappears again completely behind the lid. While dressing, only a little of the skirt is seen from time to time behind the lid. When she straightens up she is fully dressed in the ballet clothes and comes to the foreground to put on the shoes.

Film B

1. (Medium shot.) The girl finds the shoes in the trunk. She makes them dance.

2. Close-up of the dance of the shoes.

3. (Extra close-up.) End of the dance of the shoes; she puts them back in the trunk and gets up.

4. (Medium shot.) She straightens up and moves out of range to the right. Only her shadow on the wall is visible. She takes off

the pyjamas, stretches out her arm, which comes into range, and takes the ballet skirt. She then disappears completely out of range again, and is seen dressing in shadow play.

5. (Medium shot.) Fully dressed, she comes into range and puts one foot on the edge of the trunk in order to put on the shoes.

Film C

1. (Medium shot.) The girl (three-quarter face), looking into the trunk.

2. (Extra close-up.) What she sees in the trunk: the satin shoes and a rose made of some material which shines softly.

3. (Revert to 1.) She takes the shoes from the trunk and makes them dance.

4. (Extra close-up.) The shoes dancing (her hands are not visible).

5. (Medium shot.) End of the dance of the shoes. She puts them down, takes the ballet skirt, and tries whether it will fit.

6. (Distant shot.) She holds the ballet skirt in front of her to see whether it suits. She stands on tiptoe as if listening to music.

7. Dissolve into the same format as 6, showing her in the same action (stepping lightly from one foot to the other), but, as if by magic, dressed differently: dance shoes and ballet dress, hair now loose on her shoulders.

We see clearly how the same action can be presented in three different forms. The first is more 'realistic'. The second is the most unusual and requires an effort of interpretation. The trick used in the third gives the dressing up something of the appearance of magic.

The ideal experimental design would have been the Latin Square if it had been possible to have three films each presented in three different forms, but it was impossible for financial reasons to go that far. We shall deal rapidly with the material arrangements for the experiment, but will go into some detail about the questioning which followed the projection.

After a good deal of trial and error, a model questionnaire was prepared so that the actual form of the questions would be as uniform as possible. To obtain a spontaneous account of what the child had seen, the first question was: "This evening you will tell your mother about what you have just seen; what will you say to her?" The order of sentences in the reply was noted for analysis later. Then more precise questions were asked. As children can be embarrassed by the poverty of their vocabulary, it is not possible to rely on oral responses only. We therefore mixed some stills from the film with other similar photos, and the child was asked

whether the object or view shown him was also in the film. Again, the same sequence was represented by several photographs, and the child (this is a well-known technique) had to arrange the pictures in the same order as in the film. We constructed a model of the attic in which the little girl danced so as to study the difficulties the child had in locating the objects in relation to each other.

All these checks were necessary to avoid the obvious criticisms that could be made had the examination been verbal only; there is also the question of being able to compare the responses for the purposes of statistical interpretation. We now give a general summary of the results.

It can be said, first of all, that there is no necessary relationship between the technical difficulties and the psychological. At first sight it might be thought that a lap-dissolve, a change of scale, or a reverse field shot would, by its very technical complexity, introduce something children would find difficult to understand. The results seem to show that in certain cases, on the contrary, a close-up makes the action more explicit and facilitates the understanding of what is happening. We were able to verify this precisely in the sequence when the girl arrives in the attic and puts the candle down on the stool. We would even be tempted to suggest (this is to be checked later) that a very variegated film is more comprehensible to children if a good deal of use is made of juxtaposition. This is not a question of accelerating the rhythm. If the general idea is not sufficiently 'interpreted' by the child, the close-ups and medium shots will provide additional aids to a proper comprehension.

Here we reach one of the fundamental points our analysis was concerned with—the reconstruction of the action by the child. As the psychologists have very clearly shown, a child's understanding of an action is a reconstruction on the basis of a few scattered elements. The deliberate cinematographic ellipsis allows an analysis to be made of the child's reaction and the distortions (by addition or subtraction) he makes of the real thing; these results would appear particularly important in determining, when a teaching film is being planned, the most favourable framework, the one that will ensure that understanding is as good as it can be. The parallel forms provided by the second and third films made it possible to show that the younger children were incapable of deducing where the girl was dancing from what they were shown at the

end (the mother going up the stairs), but the intermediate group did.

Another difficulty became clearly apparent during the various analyses: the children all found it practically impossible to locate the various parts of the scene in relation to one another. We were unable to get a correct description of the places in which the action took place from the photographs, models, or (in the case of the older children) sketches provided. Did the subject of the action engage all their attention? Is there any good technical means of creating some element of ambience? In making instructional films these two questions are of vital importance.

A child will give full rein to his imagination in the invention of objects, actions, colours, and feelings. We tried to find out how the meeting between the mother and girl was felt affectively. The poverty of children in projecting feelings is common knowledge; it was only with the older children that the relations between the two characters were better and more comprehensively understood.

These findings on a specific experiment can serve as a guide to us in similar experiments. Before proceeding farther, however, we should like to show, by an example, how cinema style can be used subtly to modify the quality of comprehension and add a particular colouring to it. Let us take a case which can easily be transferred to the screen: a car brakes suddenly to avoid a child on the road. The sound situation is reproduced as faithfully as possible, but the emphasis can be placed on the cry of the child, or that of the driver, on the noise of brakes or on other noises. The film-maker will choose his images according to the affective colouring he wants to impart to the stopping of the car. The following are possibilities which are not mutually exclusive, but call the spectator's attention to some specific aspect of the situation: close-up from the car of the terrified face of the child who is in danger of being run down; close-up showing the emotion on the driver's face; close-up of the foot on the brake if the object is to emphasize the tremendous muscular effort the driver is making; close-up of the mechanical side (tyres, for example) if the interest is to be directed there.

It can be agreed that, as from a certain age (see following paragraph), all spectators will understand what is happening; they will understand that the car is stopping. But there is understanding and understanding. It is the little extras, the additional shades of understanding, which lead to full artistic comprehension in the cinema.

Cinematic comprehension and general intellectual level

Several writers have considered cinematic comprehension in relation to intellectual development with a view to making a better analysis of the way in which intellectual activity operates during a film showing. Heuyer (106) indicates that his investigations enabled him to establish, with accuracy, the relations between intellectual level and film understanding. Below the seven-year mental level the child sees images, understands short sequences, but cannot follow them in logical order; below the 9–10 level he can follow the sequences, but does not grasp their significance. These results agree with Zazzo's (229). A single sequence of four shots is understood at the age of seven, but the child cannot follow the 20 or 30 shots which form a full-scale film. Zazzo goes on to say it is probable that, even when he becomes deeply involved in the film, the child does not follow the line of the story it tells. It is only from 9 to 10 onward that he can follow the order of the shots. Between a mental age of 10 and 12 he can follow the continuity in the sequences, but cannot grasp its significance. It is from a mental age of 12 that, in general, he can understand the film as a whole and becomes capable of grasping its central idea.

These results are not surprising, being similar to all those found in genetic psychology, but it is still necessary that psychologists should determine, for each type of film, the age at which it can be correctly apprehended by the intelligence. And here it must be added that, as Zazzo says, "we have to recognize that this demand for logic is a luxury; the cinema has plenty of other satisfactions, and the child does not worry about not understanding".

It is not difficult to imagine that, reversing the perspective of the present investigations, it will be possible one day to use the film to make a diagnosis of intelligence; why should what has been done for the affective life (see below) not also be possible for the logical component of our psyche?

Qualitative aspect of comprehension: organization of the child's retelling of the story

With the encouragement of a school inspector, a group of teachers produced some very up-to-date conclusions from experiments made in infant schools, and their specific findings provide a basis for Zazzo's remarkable interpretations. The following is quoted from their report:

What results did we obtain? Obviously they varied with age and with the particular films. . . . From the point of view of general comprehension we think certain well-defined cases can be distinguished—namely: the child, using parts of the film, makes up a complete story; he remembers images but has not grasped the point; he names characters or retails facts correctly, but apparently without making any link between them. His retelling constitutes an enumeration or juxtaposition, not a coherent whole; finally, at the most advanced stage, he produces a version which is more or less picturesque but always accurate.

The film has been understood in broad outline. Various details may not be remembered, at least spontaneously, and he does not think it necessary to recall them.

The problem must also be regarded the other way round—*i.e.*, what prevents the child from understanding. This will give, in negative form, so to speak, other aspects of the mental activity involved.

The report continues:

However, causes of another kind intervene to hinder or prevent the comprehension of a series of images which constitute a logical whole. We have found non-recognition or imperfect recognition of the image. Certain parts, moreover, are wholly strange and consequently cannot be identified. Sometimes elements recognized in a general shot are no longer recognized when they appear in close-up and vice versa. Perspective effects and the play of light and shadow hinder and sometimes prevent exact perception. Hence the ignorance and inexperience of the children, coupled with the very character of the projected image, are themselves the causes of many gross errors and prevent the understanding of the story as a whole or certain of its parts, so making its reconstitution impossible.

The gaps may be few or many. Attention cannot be uniformly maintained all during the projection; certain images may suggest others to the child who lets himself be carried away by his imagination, forgetting the film for the moment and reverting to it only when it is too late to grasp the sequence of events.

Even when the story is accurately reproduced, the facts are retold without their relations of cause or time being established. Sometimes a series of statements is made without any apparent causal link; poverty of vocabulary, no doubt, but above all mental incapacity to distinguish, and hence to express, what is cause and what is effect. It would seem that the projection of filmstrips even more than the showing of films encourages and maintains this form of thinking which is characteristic of childhood. (At this point the reader should recall the results indicated earlier about the comprehension of filmstrips.) Sometimes there is a vague, ill-defined link which expresses the succession of

events rather than relations. (*e.g.*, he called his wife, then he called the little boy, then the girl, then the cat.)

A minority of the young children did appear able, however, to establish a causal link. The means employed are certainly poor, but this does not matter. An important stage has been passed: the child can discern what is cause and what is consequence, and the verbal forms seem to describe this essential relationship explicitly. Sometimes there is even an attempt at fairly complicated reasoning, requiring several propositions for its expression. It is seldom that children think out their reasoning completely, and most often the adult has to re-create some of the missing links. It must be emphasized, however, that these advanced forms appear in only a few children aged 5 to 6. In many, if not in most, cases the facts are enumerated in logical order, but not located in time. It would appear that the filmstrip or film scarcely helps the children at all in making this location in time, which is already difficult enough, but is made even more so by cinematographic technique. Some children, however, seem to be conscious of duration and make touching efforts to reproduce it. For some the time link is vague, and duration never becomes specific, but there is still a very clear idea of succession in time. The same terms recur: "first", "and then", "after".

In the most advanced children there is marked effort to render time and to estimate its duration. This effort seems to be frustrated by the implacable opposition between real time and film time, and by the very few reference points which their short past life affords. It can be noted that children try to measure time either by relating it to a reference point (usually that provided by the film), to a series of actions (the more the completed actions the longer is the time), or by a combination of both. But most often the idea of time remains vague, and is always less in duration than the actual time involved.

Size relationships are perceived by only some children who express them more or less skilfully. Piaget informs us, moreover, that the idea of relationship is late in developing in children (10 to 12 years), and we come back by a roundabout way to the Geneva findings.

Often a false interpretation or at least one which does not fit the story brings the explanation and hence the comprehension down to the level of the child's experience.

Apparently certain situations which deeply move children in

daily life or greatly interest them are matters of complete indifference when suggested by an image—*e.g.*, children of 6 to 7 who had watched over the hatching of the school tortoises with affectionate attention were not at all affected in the same way by a similar situation in the film—the devotion of a swan for her cygnets. The power of generalization and identification of similar situations prevents full comprehension.

All of this is summed up in the following passage from a talk given by Zazzo (230) on the relationship between comprehension and the structure of the child's version.

The way in which the child retells the story as a whole has its own intrinsic difficulties. There must be a minimum comprehension of the details before he can make a fairly correct recital of the whole, but, on the other hand, it is quite easy to see that the comprehension might be correct and the recital incoherent. In fact, however, there seems to be a fairly close relationship in our results between the capacity to understand and the capacity to describe. There is no doubt a gap, long since known, between the appearance of comprehension in the child (comprehension of vocabulary, for example) and the ability to express it. But here it is a gap in the same function at two somewhat different levels. To understand someone else's telling, the child must to some extent be able to tell the tale himself. To him who hears, as to him who tells, the recital follows the same basic pattern irrespective of the degree of intellectual and verbal organization required.

In the case of a cinema show there may be an additional difficulty for the child which arises from an initial misunderstanding; the situation does not follow an explicit story pattern, and he is completely confused when asked later to tell the story in his own words. Even when he is told in advance that the film is going to tell a story, the impression of reality given by the moving pictures soon eliminates the impression of fiction. Telling implies a verbal form and the intervention of a speaker. In previous experiments Mme Zazzo noted that retellings of films even in children ten years old rarely took narrative form. The description is made more dynamic by the cinema, but the actual story is broken up for a long time by the picture form; the visual data impede a logical, verbal organization.

To summarize the various investigations made into the child's understanding of the cinema, we shall quote this passage from Zazzo:

I should like, however, to draw this contradictory and paradoxical conclusion that, compared with other means of expression, the film seems to be at once easier and more difficult to

understand. This, in brief, is because comprehension (or, more exactly, the impression of comprehending) is situated at two very different psychological levels.

From the age of seven, the child is capable of a general synthetic comprehension which, when the film does not last for longer than ten minutes, allows him, approximately at least, to grasp the general lines of the action.

But he has to be much older before the film is really intelligible and he can understand the logical unfolding of the action. This form of comprehension hardly appears at all before the age of twelve.

Retroactive effects of comprehension

The purpose here is to indicate how audio-visual techniques enable us to analyse and understand certain psychological processes. The phenomena of the gradual development of retroactive inhibition will be dealt with later. In reality, these phenomena can be observed in ordinary situations, but they are more difficult to study experimentally.

A happening, negligible in itself, perhaps, may suddenly help us to understand something that had remained inexplicable in the past, or may upset all our ideas, and the same applies in the cinema where the hypotheses that one is led, implicitly or explicitly, to make are constantly being revised as a result of information received during the projection. It would take a very long interlude here to explain how the various psychological theories deal with these phenomena. Thorpe and Schmuller (206) indicate that recourse can be had to hypotheses of association, to hypotheses deriving from conditioning, to those which derive from Gestalt, or to those which might be grouped together as functional. It will, moreover, be seen that these different psychological theories never completely explain all the phenomena; there are some aspects which one will clarify and others which will refuse to fit in. This is because the human psyche is particularly complex and does not operate in one key only. Depending upon age, the moment, circumstances, influences received, and the personality of the subject—itself dependent in turn on the factors mentioned—psychological functioning will follow one mode rather than another, will fit into one mould rather than another. There is no question here of rejecting the various theories; each of them presents facts systematically, and their various interpretations allow us to see how much has really been explained and what still remains to be investigated.

To come back to the retroactive effects of comprehension we shall see that, regardless of the theory adopted, audio-visual techniques will enable us to study them experimentally. From a series of groups of subjects it is possible to see what each new element brings to the understanding of what has gone before. This can be seen by stopping the film at a crucial moment and questioning the spectators; by working on several groups it is possible to follow the development of the intellectual process and see how new information is integrated with the old or transforms the comprehension of it.

Experimental work has been done on this point by Cohen-Seat on the basis of small changes in an actual film. Let us take an example from a very short film in his thematic film test series. A young man is taking the breakfast that has been prepared and just served to him by an older woman. While he is eating the buttered bread she sits down on a chair and watches him; for a moment their looks cross. Experience shows that there are a whole series of possible interpretations of the relationships between these two characters. Some will be eliminated if the duration of the look exchanged is prolonged by a few frames. The whole scene then takes on a new affective colouring as a result of this look, even though this occurs at the end of the scene. Through the use of techniques similar to that of this small film, variations in the partial interpretations in relation to the whole can be studied and a true experimental investigation made of the development of comprehension.

Comprehension and film structure

The two preceding paragraphs have shown the difficulties the child has in attaining cinematographic comprehension and the complicated dynamics of the mental process. However, we did not take into account another fundamental factor—the structure of the film itself. It is always open to question whether the child's incomprehension derives from his particular mental organization or from the poor structure of the projected document. (During the investigation into the comprehension of filmstrips referred to above we succeeded in demonstrating that some of the frames were themselves the cause of partial or total non-comprehension.)

On a purely logical basis, films could be classified into series in terms of their logical coherence, from the film composed of totally independent shots to that in which the link-up is perfect. Experience

has shown that adults automatically look for the story in a film and invent one which will link any very disconnected sequences together. Here it is not comprehension which is involved but inventive possibilities which lead to enormous misunderstandings. When a film is incoherent the spectator is obliged to recall the various successive sequences, and his reconstruction will not be faithful because factors of personal interpretation have taken precedence. We already know that, in a normal coherent situation, the witness is never absolutely objective. Wallon makes a remarkable analysis in his *Principles of Applied Psychology* (212)

The evidence of a simple spectator, although knowledge is apparently its only mainspring, is also a personal reaction, that of a participant like the others, and results from and contributes to his inclinations, his experience, his life. The supposed neutrality of a witness is an impossibility. His first surprise once over, he takes sides, if only by his effort to understand and explain what has happened. He assimilates details and circumstances to cases, ideas, principles, or theories which are rarely devoid of some affective value for him or fail to induce preferences or aversions. Even his intellectual interest is influenced. To fix something in the memory is already a way of telling it to oneself, often of actually telling it and experiencing it vicariously. From the very outset, evidence is the product of an operation which continues more or less actively, aggravating the initial distortions.

Accordingly, when a child or adult sees a film whose action seems obscure and whose sequences do not seem to follow a logical order, a very personal interpretation is brought into existence and is sometimes very remote from the original. It is reconstruction or invention, not the sort of ordering referred to in the investigations mentioned previously. It might then be asked at what moment will the general interpretations of the spectators tally with the maker's intentions? Two thresholds are certainly involved, one relating to the cinematographic work, the other to the psychological capabilities of the spectators. Psychologically, there is thus justification for having films prepared especially for specific age groups taking into account the various factors referred to above. This important question will be dealt with in the last part of this study.

Comprehension and film content

It is essential that we provide additional information about the question of the message referred to in the first part of this study. We have just been speaking of film content with reference only to

the relation between consecutive shots and their general coherence. We must go farther and inquire into the relationship between the subject's experience and the content of the film (content here being used in an even narrower sense).

Cohen-Seat distinguishes five different cases, each corresponding to specific psychological problems. In the first the situation is familiar to the spectator who, if he is a child, need make no effort to recognize the scene, the characters, and the action. The processes of comprehension are a matter of logic, and the story can be put together without having recourse to other psychological functions.

Sometimes the situation is so familiar to the child or other spectator that it evokes intimate problems and personal preoccupations, and the whole affective make-up of the subject feels the shock. Show a child repulsed by its mother the film *Poil de Carotte*, and you will see the extent to which his interpretation is troubled. Certain passages will be glossed over or, on the contrary, certain details will take on gigantic proportions and the general comprehension will be unbalanced. It is in this sense that the film has a projective value in the psychoanalytic sense of the term and can be an excellent instrument for investigating personality (*cf.*, in particular, the Fulchignoni test on canaries, and the Cohen-Seat thematic film tests). Here we come again upon a point made in the first part of this study in connection with the personalization of processes even when only simple perception is involved.

At the opposite extreme from these two more or less fringe cases, we find other categories of film and different situations: 'exotic' films, whose scene of action is strange to the child, and where, one might say, the action itself is outside his normal terms of reference. In the extreme case he sees a world which may be real but is completely strange to him. Comprehension is no longer at the levels at which it was previously situated. He no longer enters wholeheartedly into the action. He has to recognize or even discover the reality and significance of objects. All the gestures have to be interpreted and related back to an infrastructure of knowledge he does not always possess (because he lacks the necessary sociological or historical background, for example). It can be said without hesitation that the understanding is at two levels, since it is difficult to separate in time operations which must be carried out rapidly, if the contact with the story is not to be lost; the elements of the situation must be identified and the action linked up so as to yield a story that will lead to understanding. Misunderstandings can

obviously occur—*e.g.*, a perfectly logical ordering of the story can be reconstructed from parts of it which have been incorrectly interpreted; a total lack of comprehension can derive from the inadequate experience of the child.

We are also remote from reality in the world of the fairy-tale, fantasy, or, more simply, the cartoon. At what level does logic now operate? Is there anything significant in the way in which the story is ordered? Affective factors are reintroduced, but otherwise than in films which touch the spectator's emotions. The witch in *Snow White* frightens children. The emotions induced by the film disturb the intellectual act, whereas, in the cases previously mentioned, it was the internal conflicts which were responsible for partial or mistaken understanding. In other words, the lack of comprehension can vary qualitatively from case to case.

On this basis we can understand certain collective phenomena. We are slightly outside our subject here, but it will help to clarify certain reactions in children. People often wonder why some films are unanimously appreciated while others, at least their equal in artistic value, lead to heated discussions and divided opinions amongst spectators in general; some are enthusiastic admirers, others ferociously critical. The explanation can be found in the relations between the spectator and the screen situation. We do not feel particularly involved in an exotic film or fairy-tale; we really are spectators, and our judgment on the film involves logical factors only, discussion being a matter of explanation and objective argument. In the case of films which deal with familiar situations or touch us personally, on the other hand, the discussion cannot be purely logical, since the spectator feels involved. He has not, as previously, simply been an observer, but has participated, and a purely neutral attitude is therefore almost out of the question. The discussion will no longer turn on logical arguments, but involve each of the participants directly, and the arguments will be correspondingly more heated.

Reverting to our original subject, we find that an important educational question now arises: how can films or audio-visual documents in general ensure the child's participation, and what are the limits which should not be exceeded? The participation must be such that it arouses interest and facilitates understanding without, however, affecting too deep a level of the personality and thereby probably disturbing the process of comprehension. There is plenty of room for experiment here.

Contribution of a film on mathematics (156)

Comprehension does not always consist in grasping the narrative thread of a definite, live story. The subject may be abstract and geometrical, and we then become involved in mathematical comprehension.

In order to obtain an accurate evaluation of the contribution made by a film as compared with that made by a lesson, we carried out an experiment with two halves of the same class. The first group had a lesson on the area of a parallelogram; the same lesson was given to the second group, and a short film on the area of a parallelogram (Br  rault) was shown.

Brief analysis of the film. The investigator studied the film very closely so that he would know all about the contents before preparing his check questionnaire.

It was in three parts:

1. The parallelogram was defined visually by two pairs of parallel straight lines which cut one another. Vocabulary introduced: *the base*.

2. Equivalence of the surface of the parallelogram and of a rectangle having the base of the parallelogram as its length and the height as its width:

(a) Triangle formed by a perpendicular line at the two bases.

(b) Movement (animated cartoon of the triangle moving in order to form the equivalent rectangle). The small triangle was moved about in order to familiarize the spectator with the idea that the surface remained the same. Formula for calculating the area of the parallelogram.

3. Study of two changes in the parallelogram:

(a) Change in a rectangle having as its sides the sides of the parallelogram, with a consequent increase of the surface.

(b) Parallelogram having the same base and of constant height.

The commentary on the film was simple and unadorned, and seemed suitable for the children concerned (9-10 years).

Experimental plan and general results. To find out what its additional contribution was the film was projected to half the class, following a conventional lesson on the area of a parallelogram given to the full class. The results were evaluated by a questionnaire. We need not analyse them in full and shall simply refer to a

fact which might at first appear insignificant, but which seems of considerable importance for an analysis of the psychology of comprehension.

In the film the equivalence of the respective surfaces of the parallelogram and rectangle were shown by an animated cartoon in which a small triangle, like a small character in the film, detached itself from one side of the parallelogram and moved to the other in order to constitute a rectangle. The children laughed a lot and were obviously amused by this little abstract comedy of drawings. It could be thought that the distraction might be a hindrance to understanding. The questionnaire naturally included a question on the transformation of the parallelogram into a rectangle, particularly as they had actually made it themselves with paper and scissors. The answers of the group which did not see the film were 37.5 per cent accurate, as compared with 72.2 per cent in the other group. An analysis of the other replies on the same subject supported these results. It can, therefore, reasonably be concluded that the film leads to a better understanding, thanks to its more dynamic representation of certain geometric data, and that the child's own physical activity, while helpful, is not in all cases sufficient to produce maximum comprehension.

The same could be said of all films on mathematics. They introduce a dynamic element which, unfortunately, the geometry teacher has at his disposal only in the rare cases when he has special equipment. This particular experiment recalls all the various analyses which have demonstrated both the complexity of psychological phenomena and the impossibility of completely separating the purely intellectual from the other aspects of our comprehension. To the extent to which a film provides a general view, in geometry or elsewhere, it is enriching and facilitates a more accurate comprehension than a purely verbal presentation. Moreover, a film presents the data dynamically, and thereby introduces new possibilities of comprehension. This particular form of comprehension has still to be closely analysed, but that is a matter for the psychologists.

Cinema and conceptualization

Comprehension, even when it consists of following the story correctly, is not the only aspect of the intellectual processes which the cinema brings into play in the spectator. It has been said repeatedly that the film transmits, not concepts, but images only.

This need not prevent us from examining the rôle these images play in promoting intellectual activity or in comparing the image and the word, content and symbol. The problems involved, vital for the teacher and perhaps also for the future of thought, are far from having been clarified or even stated sufficiently explicitly to allow valid experimental research. Here a simple outline of them must suffice.

Human evolution might be summed up—admittedly in a very rough and over-simplified fashion—by the title of one of Wallon's books, *De l'acte à la pensée (From Action to Thought)*. Language is developing more and more, and what Pavlov refers to as its second system of signals gives us increasing mastery over the universe. Language reflects one of the vital aspects of thought, and the enrichment of the vocabulary and of syntactical forms (itself reflecting the ever-growing hold action is gaining on reality), finally, by a leap the animal cannot take, leads to the power of conceptual thought. This gradual but sure development of the relationship between basic information and conceptualization has been rudely shaken by the extraordinary development of mass communication media, the uninterrupted flow of images that is continually flooding mankind. Without going into the philosophical dispute as to whether there are pure or *a priori* concepts or only *a posteriori* or empirical concepts, we can say that this question is vital, and, without putting forward any particular hypothesis about the formation of the concept in the child, can consider how the question appears under present circumstances. (*cf.*, the following fundamental works: Wallon: *Les origines de la pensée chez l'enfant (The Origins of Thought in the Child)*, *De l'acte à la pensée (From Action to Thought)*; Piaget: *La formation du symbole chez l'enfant (The Development of Symbols in the Child)*).

It is interesting first of all to know whether the spectator clearly distinguishes between the cinematographic image and reality. It can be stated that a certain level of development has to be reached before a child can experience the cinematographic situation as an artificial one in which he participates only as a spectator and in no way affects it. In the same way as young children become so involved that they try to warn Punch of the policeman's arrival, children and even adults become so absorbed that, in their confusion, they act as they would in real life (covering the eyes, crying out, grasping the arms of the seat). As Michotte has pointed out (see above), the conditions of the projection facilitate this

forgetting of reality and impart such intensity to what is happening on the screen that, in the passages in which the emotions are most strongly aroused, the normal adult spectator can pass very easily from reality to the fictitious events on the screen.

What may be only temporary and, in fact, uncommon in the adult can happen frequently to the child or the adult who goes to the cinema rarely or not at all. It may be recalled that, soon after the end of the last war, a radio broadcast by Orson Welles about the landing of men from Mars caused a general panic among those who heard it. The story is told of a grandmother who, going with her grandson for the first time to the cinema to see a film about the foundation of independence in the United States, said to the teacher that she was very glad to have been there because she had often seen pictures of George Washington but had never heard him speak. These examples illustrate that the dissociation between reality and the cinema show is not a question of a simple determinism and is difficult to pin down and investigate.

It is obvious that where the child's perception is only syncretic and where he cannot distinguish cinema images from those of real life, it is irrelevant to speak of the cinema's relation to conceptualization. As Wallon points out, it is important to analyse and understand "the conflict of words and things" in the young (216); at the level with which we are dealing, how does this conflict of words and images appear, or, to put the question in a more general way, how does the cinema pose the problem of the relations between the extension and comprehension of a concept, the images and the sign?

We have said previously that the film does not transmit concepts, but we consider that it can play an important rôle in the development of certain ideas, in the passage from something specific to something more abstract and formal. In all these studies we are bordering on the great problems of psychology and philosophy, and, to prevent this study from taking on excessive dimensions, we shall start with concrete examples.

Thanks to the possibilities of montage and trick photography, the cinema can be a wonderful instrument for bringing data together and facilitating comparisons and analyses. The spectator can be taken from Vesuvius to the volcanoes of Japan, from Japan to Martinique, from there to the French Alps. The image can bring the geographical structures together and show their similarities. Then, on the actual picture, a drawing can be superimposed; a

typical volcanic topography can be used to demonstrate clearly the volcanic outline of one actually being studied, and then of volcanoes in general or of any particular volcano. The flexibility of presentation, the rapidity with which examples can be brought together, and the evidence afforded by the drawings quickly impart the idea of volcanoes to the child. Nor should we neglect the importance of the opportunity the cinema offers of going back from the image to the drawing, a technique that can be used to the maximum, the image being enriched by the abstract line which stresses the important elements in it, while the drawing keeps closely in touch with reality and is no longer dry and abstract.

This passing from picture to drawing has an enhanced value when, in bringing together objects, landscapes, or machines very different in outward aspect but having a similar structure or operating in accordance with the same laws, the cinema can utilize superimposed drawings. It would be easy but superfluous to illustrate: from the lever to the theory of machine tools, from elementary biological processes to the most complicated phenomena of life, from the simplest picture of a tiny stream to the spectacular canyons of the chalk lands.

However, it is not only in connection with the concrete and physical that the cinema can help the child to accede to representation. The great concepts of our civilization can be illustrated by great films or musical works which create a new awareness, an inducement to embark on new discussions or activities, thereby opening the way for general ideas (the idea of justice in the films of Cayatte, for example). It must be stressed that the film will not in itself suffice to convey the concept as such to the child or adult, but it can rightly be said that it prepares the way, facilitates the transitions, enriches the ideas, and clarifies the outlines. The educator can then step in to continue and complete what the film has started.

This genetic aspect apart, cinematographic illustration can be used to analyse the relations between an ordinary word and various aspects of the concept it expresses—*i.e.*, to use the language of philosophy, its extension and comprehension. In the mind of the spectator, child or adult, three main situations may occur: signifying and signified coexist; signifying only exists; neither signifying nor signified exists. The first situation can itself give rise to two different attitudes. For example: my idea of a canal lock can be correctly illustrated by some well-chosen pictures or the picture I

am given may not exactly coincide with my experience and hence with the meaning I give to the term. In the first case I will admire the quality of the film which confirms my beliefs and ideas and consider it good because it is true. In the second case the film will either enrich the concept I already had by showing me various types of canal lock which I had not thought of and did not recognize, so that I learn something and make progress; or else I disagree with what is shown as not being in accordance with what I already knew. Depending upon the personality of the spectator, the idea of the original will remain unchanged and the film will be considered bad, or the idea will be transformed and the film will contribute to his psychological progress.

We next come to the case in which a person knows a word or formula but is not capable of giving content to it—*e.g.*, someone, during a conversation, uses the expression 'boomerang effect', and the expression is found to be as arresting as the word 'presby-tère' was to Colette, the word which she found 'mysterious', its hoarse, embroidered initial outline culminating in a long and dream-like syllable. Despite the dictionary explanation that the boomerang is an object of a certain shape which, when thrown, comes back of its own accord to the point of departure, it is still difficult to form an idea of what exactly is meant by 'boomerang effect', so lightly dropped in conversation. The film can clarify the point by illustrating a boomerang, showing how it works, and then indicating how a man can use it for fighting or hunting. The spectator can then see exactly what this extraordinary boomerang effect is, and the formula will take on a very precise meaning for him.

In the third case the film introduces an idea the spectator does not yet possess and illustrates both the signified and the signifying. This leads to a new problem which will now be dealt with.

III. CREATION OF MOTIVATION

As we have just seen, certain problems or ideas may be entirely new to the spectator. These being neither signified nor signifying, he is suddenly faced with something which is new to him, and we must ask ourselves how, psychologically, we can try to lead him to a higher level, teach him a technique or some particular line of conduct, give him the feeling of the problem. Making someone

aware of a problem is a help towards enabling him to deal with it.

In this light, let us see what rôle the cinema can play. To make the point clearer let us take the example of the teacher who wants to induce children or adults to go for vaccination. It might be thought that a film would suffice to show the necessity, and that proper arguments would overcome any possible reluctance. That view takes no account of the complexity of the psyche and the reciprocal operation of intelligence, affectivity, and conduct. If the ground is not sufficiently prepared, the result may be traumata or implacable opposition, and the reverse of what had been expected. In brief, spectators must be given a powerful motive for wanting vaccination, and this has to be done in stages. What will be said here about health education can be applied, *mutatis mutandis*, to other forms of learning; hence we shall simply indicate what certain types of learning require, and in particular the learning of certain gestures.

The first stage might be taken to correspond to an imaginary zero in a scale of development of motivation: the spectator sees the film, but it does not succeed in radically changing his ideas.

At a slightly higher level, the film may fulfil a special function. Thanks to its potentialities and the psychic phenomena to which it may give rise (see above), the cinema, while explicitly setting out the component elements of a problem, can create a kind of intellectual uneasiness, and the spectators will understand in a still rather confused and general way that a problem does exist. Such films do not, as in the first case, leave the spectator entirely unmoved with no questions to ask, but do not intellectually satisfy him either—in short, a well-made film troubles and makes the spectator want to find out more. Let us, for example, take the case of a film showing a family in which a child has died. From the way the film is made it seems that the tragedy could have been avoided, although its cause or the means of preventing it are not shown. This certain degree of uneasiness, necessary to bring about a change of conduct, should not go beyond certain limits as otherwise traumata which inhibit action may be provoked.

In the third stage the need created by films of the preceding type might be met, the spectator being helped to make explicit the problem which has been posed indirectly and which has created his difficulty. The explanation now alleviates the psychological condition. It has long been a dictum in teaching that a lesson should

always be a reply to a question the child himself asks. The same applies here. The film explains the elements of the previous situation, relates the facts, and links cause and effect; we are at the stage of understanding and of scientific explanation when the spectator will learn why the child died, what mistakes were made, and how a microbe or virus provoked the disaster, but he is still left with a question. If the film has been well made, a need has been created; the situation has been clearly explained and he will normally ask himself how the disaster could have been avoided.

A last type of film provides the theoretical and practical solution to the problem. On the theoretical side, by explaining what vaccination is, the way to avoid the disease is indicated; but what any spectator must do in order to have himself vaccinated is also specified.

These hypothetical stages can be brought together in a single film. There is nothing very new in all this; it is simply the old teacher's maxim: get the child interested, explain, and then make him act. In the case of the film, behaviour has been greatly influenced by the fact that the motives for it have been given and explained. The behaviour proposed is all the easier to accept because all the spectator's psychological forces combine to induce him to undertake an action which is the logical consequence of the situations he has been watching. He is not given the impression—and this is especially important with adults—that he has been forced to adopt a given line of conduct; on the contrary, he believes he has himself discovered his reasons for acting—and this is true in part—and is convinced that he is going on his own initiative to have himself vaccinated.

We cannot leave this ideal view of things and go on to more definite problems without a few comments. As previously indicated, the foregoing can be applied to what is now by common consent called apprenticeship and, in a more general way, to the determination of behaviour, whether it be teaching safety rules to a child or workman, learning how to handle an instrument or tool, using some particular form of teaching, making citizens vote, or teaching girls child-care. The logical sequence is the same, and what has been said above applies with very little need for modification.

The effects on individual conduct—and this is one of the teaching problems dealt with in the last part of this study—can be

manipulated—*i.e.*, placed at the service of any code of ethics, any ideology, any policy. Accordingly, it is easy to foresee the possible dangers that these audio-visual techniques may involve.

SOME REMARKS ON APPRENTICESHIP

When a gesture or series of movements has to be learned very precisely (as is the case not only in vocational education but in a great variety of school subjects, from writing to physical culture, taking in manual work on the way), the above remarks hold good, since the apprenticeship must have its reasons and the learner must be made to feel he has a problem that can be overcome only by methodical training. However, a gesture can be more easily learned than a line of conduct, and the educational psychological processes involved can be examined a little more closely.

In the first section of this third part we discussed empathy phenomena and recalled the rôle that Wallon assigns to the tonic function in imitation processes. We are not reverting to this important question, but merely recalling the importance of being able to observe movement properly. It is possible by trick photography to give a general view of a movement at normal speed, to slow it down in order to analyse points of difficulty, and to come back to normal speed again. We are not concerned here with breaking down the movement or adopting the view of the atomistic pedagogue, but with the technical possibilities offered by the ability to change the speed at which the photographs are taken. Incidentally, the slow or fast thresholds must be respected, or the movement will be qualitatively distorted.

How should the movement to be copied be presented so that the learner will recognize it and want to reproduce it? It has rightly been said that the spectator must be able to identify himself with the actor who carries out the movement. But it is not always advisable, for example, to have a physical education movement demonstrated by a champion athlete—who is too obviously skilful, to the discouragement of the learner—or by a fat, awkward child—the learner then being annoyed at the implied comparison with such a puppet. The same could be said about the movement itself. If the muscular movement is too simple, imitating it will teach nothing; if it is too stylish, it will be beyond the child's powers, and no communication is established; asking a boy to lace his shoes with the grace of a ballet-dancer is to ask the impossible and to invite almost certain failure. It can be seen, therefore, that all

sorts of precautions must be taken if the indispensable motivations to the apprenticeship are to be brought into existence.

In the second part of this study we discussed the tonic conditions of perception and of the phenomena of empathy, and we can therefore understand the effectiveness of the cinematographic example. We must add to this that, thanks to small individual screens—or even one large one—the learner can see before him the movement carried out as he himself should do it. The hands of the demonstrator on the screen are in the same position as his own, the situation he sees is similar to that in which he finds himself. To complete the apprenticeship and allow repetitions, the film can be projected again and again—that is, if it is not already made in such a way that the movement can be shown many times without interruption. The film thus leads him on, leads him to copy the movement and, in doing so, trains him. The two aspects are obviously linked, and, to some extent, parallel the tonic and the clonic activity in muscular movement.

All that has just been said about the apprenticeship of a limited action (learning to use a tool, for example) applies to a whole series of apprenticeships which go well outside the motor aspect of behaviour. This can be used to explain certain fashions and snobberies which the appearance of a new film or a great star can produce, and, in this respect, the cinema has a definite cultural influence.

CHAPTER 4

CONCLUSIONS

This study is not purely pedagogical in purpose and will accordingly not deal with the methodological problems involved in the utilization of audio-visual techniques in the school. However, the educational and psychological perspective brings us automatically back to practice, if only to draw the immediate consequences of the scientific analyses of the preceding pages. In these concluding pages, therefore, the reader will not be told how he should use a tape recorder in class, for example, but will find some general considerations which may help to clarify present teaching practice and a reference to some new problems which are outside the scope of this study.

The main points of our introduction are clearly set out in one of the working documents distributed to participants at the seminar (224); it, incidentally, also outlines certain important current problems.

The introduction of technical facilities in schools raises certain problems in teaching techniques. One is the teacher's relation to these technical facilities. In our opinion the teaching and education of young people cannot be reduced to the mechanical transmission of knowledge, habits, and standards and mechanisms of behaviour. The teacher must have the main rôle in the complicated and variegated educational process. All technical facilities are mere auxiliaries for the teacher, multiplying the ways in which he can work on the child; in themselves their possibilities are limited.

This is why we think there is no point in raising the question of replacing the living teacher by a television or electronic robot.

This is the point of departure for all our research on the utilization of technical facilities in teaching.

Its object, in the last analysis, is to elaborate the method best suited to the teacher and determine the most effective ways of using this equipment in teaching.

Secondly, and not less important, is the problem of the relation between the pupil or student and the teaching technique used; this is much more complicated than the 'teacher-pupil' problem, and has unfortunately not yet been satisfactorily solved by contemporary educational research.

A third series of major problems has still to be considered: those relating to teaching in the framework of an evolving society and those involved in equipping to the best advantage a school which has highly qualified teachers.

Here a multitude of problems has to be faced: more active teaching methods; selective instruction for each pupil; relative proportions of work done in class and outside; creative work by pupils; utilization of technical means in general, their correlations, and successive utilization; the teacher and the employment of technical aids; the division of lesson-time into the teacher's work and his supplementary use of technical aids; the conditions under which it becomes necessary to use technical aids in order to attain a given objective; the teacher as organizer and director of the teaching process with the aid of technical aids; definition of what the teacher achieves by using technical aids; what the teacher can do and technical aids cannot, and vice versa; rôle and place of technical aids in teaching; what is necessary to achieve greater efficiency in work done in class, in the pupils' personal work, and in their extra-mural activities.

The introduction of various technical aids in teaching prepares the way for the creation of a new branch of knowledge—educational cybernetics—which will be concerned with directing the cognitive activities of pupils by trying to ensure that the operation of the teaching processes will render the pupils' own activities as fruitful as possible.

THE TEACHER'S COMMAND OF NEW TEACHING TECHNIQUES

We are all agreed that the new audio-visual techniques are and shall remain at the service of the teacher. If the result of using them is to be educational in the proper sense of the word, they must be at the teacher's entire disposal, and this presupposes two conditions: that they are easy to handle and that the teacher really knows how to use them. The material conditions necessary to ensure that audio-visual techniques can easily be used can be left aside as being of purely methodological interest, but we must analyse what we mean by his command of them. As with any other teaching facility, knowing how to use audio-visual techniques means first being familiar with all of their possibilities; being able to find new,

original, and fruitful ways of using them for purposes which at first sight seem out of the question; and, possibly, being able to perfect them or suggest improvements to the makers.

All this presupposes ample and accurate background information, technical, educational, and psychological. For the moment, the questions involved in the practical utilization of audio-visual techniques in class can be left aside in favour of the psychological requirements. For its proper utilization any human technique must be considered in terms of the psychological phenomena it brings about. Using an educational technique properly means arousing the largest possible number of positive reactions in the pupil and eliminating the negative or traumatic reactions. An educational technique cannot be correctly used unless the difficulties caused in the pupils with whom it is used are analysed, and it can be improved only if all these aspects are taken into consideration. It is in this way that the previous sections of this study will, we hope, be useful to the teacher, giving him a better understanding of the psychological processes induced by the employment of audio-visual aids, and hence more control over them. It must be repeated here that all the preceding analyses are valid only in relation to certain educational situations, and a subtle dialectic transforms the methods and the psychological reactions of the pupils. The teacher must be constantly aware of this development and adapt his working rules to situations which are all the time changing.

THE TEACHER'S CHANGING RÔLE

We can therefore go beyond the practical question of the teacher's use of audio-visual techniques and consider the more general educational aspects. For several decades the rôle of the teacher has been changing radically, a process considerably speeded up by audio-visual techniques. It was long possible to consider the teacher as the main, if not the only, source of knowledge. Before more or less regular visits to the cinema and television in the home became common, the child learned and increased his store of knowledge mainly through the school. To be more exact, we can say that the gap between all the child learned in class and all he learned outside was large, and in certain social classes very large. During the last thirty years this gap has tended to diminish, at least at a certain level and in certain respects. This whole question requires analysis and clarification: the laws of pedagogics are not simple. In certain specialized ways the school still has the preponderant share

(intellectual disciplines, for example, learning to read and to count), but elsewhere environment is clearly more influential (artistic training, travel, life in general). It cannot be denied that some television programmes fascinate children and make no small cultural contribution (e.g., in France, *La vie des animaux*, *La caméra explore le temps*, *Le magazine des explorateurs*). Hence the teacher could at one time be considered in practice as the main source of culture, and what he said was unquestioned, but this is no longer so. Whatever he may think about audio-visual techniques, the teacher has to come to terms with them for two main reasons. If he wishes to arouse and maintain the interest of the children and get them really to work, it is well, at certain points, to bring school and ordinary life together and to use in class means which can hold the children's attention. The picture does not have to rely on rhetoric; it is sufficient to watch children leaving school and passing a cinema where stills from the films of the week are on view. The use of films in a class establishes a new relationship and helps to make the pupils more attached to their school. From this first viewpoint, therefore, recourse to audio-visual techniques reflects a desire to motivate school activities and to profit from the psychological dynamism thus created in the child.

From a less directly practical point of view, the teacher who wants his work to be fruitful will decide to change his teaching standpoint for other reasons. Teachers everywhere complain of overloaded programmes and insufficient time; the order of subjects to be taught is rigorously maintained, and there is a more or less compulsory list of various types of knowledge to be acquired. Could use not be made of the ever-growing number of opportunities outside the school? If there is a good historical film in the local cinema, why not take advantage of the occasion and ask the children to produce an account of it, and discuss with them its historical accuracy? A film on a foreign country could furnish the material for a talk or a discussion on the way in which people live elsewhere, and thus provide a useful geography lesson. The Press, the radio, a contemporary exhibition, documents on a voyage, an important visit or visitor—all offer material for fruitful discussion, accurate reporting, and the formation of a critical spirit.

The teacher thus has a new rôle to play. He can no longer consider himself as the only source of knowledge—exact knowledge, that is. He knows that what the children learn outside school is not always very exact. This factor he must not neglect, nor despise

the inaccuracies which, too often, are what the child will retain. He must come back to it, rectify it, add to it, and, above all, awaken the child's critical spirit so that he too will take care, be sceptical, and exercise his judgment. That cannot be done simply by showing that the teacher is right and the film or other outside information wrong; he must go back to the facts or argument, clarify them, fill in the gaps, or put them in their proper context and demonstrate where the mistake has been voluntarily or involuntarily introduced. If he keeps the psychological problems discussed in the beginning of this study in view, he will correct the interpretations in relation to the child's age and lack of understanding of certain parts of the document concerned, and will know why the child reacts in a given way to a presentation or to propaganda.

Audio-visual techniques and all that constitutes modern information and publicity can be ignored by the teacher only at the risk of a further widening and deepening of the gap between school and everyday life.

EDUCATION AND PREPARATION FOR TOMORROW'S WORLD

Coming back to this vital question of the relationship between school and everyday life, another question immediately arises. If the rôle of education is to prepare the students of today to be the men of tomorrow, and this preparation is both adaptation and emulation, where do the relations between school and audio-visual techniques stand?

In the preceding chapter we examined the difficulties children have in understanding an audio-visual document and the complicated processes this particular situation brings into operation. If we accept the reasonable view that audio-visual techniques are characteristic of our times we should, even in the school, teach the child how to use and take advantage of them. The teacher's comments help the child to understand what he reads and to derive a richer and a deeper emotion from a given text; similarly, comments on a photographic or film document, on a recorded text or a record of classical music, should teach the child how to make contact with these new information media. The habit of analysing, explaining, and criticizing leads the child to go beyond the more or less passive first stage and to examine audio-visual messages with the critical eye of an educated person. Pupils should get used to reacting to the false image as to a lie, to protesting against a film which takes too many liberties with the truth as one should before a falsification of

the facts. To produce this attitude, which is only one element in man's control of technology, children must not only be provided with the means of recognizing error and knowing how a misleading document can be fabricated, but also be given the means of appreciating the techniques which underlie the construction of a work of art and, without killing aesthetic emotion, be helped to understand the forms that were used by its creator. We too often complain of the evil hold modern technology has taken on our contemporary life without utilizing all the resources of education to equip the spectator for something more than a merely passive rôle.

THE PUPIL'S ACTIVITIES

This brings us to the question of the pupil's activities. In conventional teaching a definite point of departure was always necessary, and official texts emphasized that activity should precede reflection and thought; quotations to this effect can easily be found in any country in the world. This activity on the part of the child is still more necessary when it comes to the use of audio-visual techniques. We can best explain what we mean by referring back to what was said above.

In discussing perception we showed that a message had to be interpreted before it could give rise to perception, and explained that the complexity of the psychological process depended upon the person concerned. If he has not had a wide and varied practical experience he will be unable to receive the full audio-visual message, and much of it will go unused. If the pupil is to understand audio-visual documents fully and derive maximum benefit from them he must not be confined to an artificial world of sound and image; these will take on their full significance only if he can relate them to situations he has experienced and if he has a background sufficiently varied to allow him to understand correctly what is shown to him.

During a film show the child is carried along by the rhythm of the film, and the time-order of his perceptions is imposed on him by the film itself. What a temptation to passivity, and how dangerous an education that relied only on the audio-visual! A child who had no antidote in the form of real and intense activity would soon develop into a person who could be carried away by any form of temptation or propaganda, his psyche becoming progressively impoverished, all initiative disappearing. We are not trying to belittle audio-visual education gratuitously—this whole

study will show that our intentions are very different. But faith should not be slavish or enthusiasm blind. The more a teacher uses audio-visual techniques the more necessary will it be to organize parallel activities that will induce the child to work on his own, show initiative, and develop his own drive. Imagine the notion of temporal continuity of a child who knew the world only through cinematographic discontinuity, where every scene is suddenly replaced by another, where persons suddenly appear or disappear, where distant times or distant places succeed each other without a break. The teacher should never forget that audio-visual techniques do not represent absolute perfection. Side by side with the extraordinary contribution they make to present-day education, they introduce dangers which must be clearly understood.

There is another reason why children should have additional activities when audio-visual techniques are constantly used in class. Taking into consideration the analysis of the phenomena of empathy made earlier, the power of certain images, and the skill of the film editor and director, films may too easily give the child the impression of understanding simply by skipping the difficulties that are involved in a proper exercise of the intelligence. When education is a matter between teacher and pupil, the teacher takes the pupil's reactions into account, adapts himself to the resistances, and exploits the facilities offered by the child's personality. If properly carried out, this teaching process will end with the child attaining the object proposed, and the cycle will be complete. By its very construction the film or sound document cannot adapt itself to the pupil; even the tape recorder, which can be stopped at will and reversed, still cannot transform the melodic line and the speed of the recorded phrase. Something additional is therefore necessary if the child's understanding is to be complete, if it is to be more than just a general or approximate comprehension and if it is to become as nearly perfect as possible. Man's intellectual activity leads to concepts and thought; mental representation does not automatically follow from the perception or the particular items of practical knowledge acquired during a film show. Modern techniques are excellent for the purpose of developing intelligence and thought, but they do not provide a panacea; they have their part to play at a precise moment in mental activity, but they never replace it. Conscious of all these problems, and in view of the importance nowadays of messages received by the senses, the

teacher must rethink certain pedagogical problems. The establishment of a triangular relationship between the rational activity of assimilation and comprehension, the information received, and the development of all the creative possibilities is certainly one of the major tasks of contemporary education, and it is one of the merits of audio-visual aids that they help to make us aware of this problem.

EDUCATION AND CREATION

We must go farther and place the child's activity on a different level in order to get at the essence of a really new education. It has been repeatedly said that real knowledge implies the ability to recreate, and that to teach expression is to teach the best form of true education. The essence of activity methods in teaching is that expression is used as a means of education, and the child is encouraged to create in order to ensure that he has understood and assimilated properly. The dynamogenic power of drawing, of bodily expression, and modelling is well known; composition is important when a child is trying to master his mother tongue; it might be claimed that really to understand a play it should be played, really to understand a musical work it must be interpreted. Many examples could be given; we might quote, with the philosopher, the formula which is a whole programme in itself: "In making, make thyself."

It can therefore be asked whether, in preparing him for a civilization where the audio-visual plays an important rôle, the child should not also be initiated in the techniques of expression by means of practical work and trained through the medium of pictures, photographs, or films. We ask pupils to talk about a given situation, to describe something they have seen while out walking, or to tell something that has happened to them. The custom of making graphic illustrations has fortunately become widespread, and there does not seem to be any good reason why an excellent description by means of photographs or a film should not be as profitable to the pupil as written homework.

The objections are obvious. The price of cameras excludes such methods on a large scale. But why not think about these possibilities now and, as soon as possible, use graphic productions made by children? With an amateur cameraman and some teamwork the shots proposed by the pupils could be taken; montage exercises would be the equivalent of planning. Certain films now made

from pictures prepared by adults could be usefully replaced by sequences made from the children's productions. There is no doubt but that the children would absorb the message better and derive more profit from it; here we can refer to ideas expressed a very long time ago by Piaget; he stated confidently from his observations that a child often understood explanations given by one of his comrades better than those given by an adult.

All this does not mean that the era of the ballpoint pen is past and gone, but we must recognize that the day of the camera or tape recorder as a means of expressing and translating thoughts and feelings is not far distant. It can easily be seen what an extraordinary enrichment such teaching aids would give to education, and what shock effects would be felt in other disciplines. All sorts of possible uses suggest themselves: the observation of a plant or animal, the choosing of a representative geographical view, the historical document found and pictorially reproduced, the analysis of a psychological situation photographed from well-chosen angles and then skilfully edited—all these give us an idea of new perspectives in teaching, of what some school activities may be like tomorrow. There is nothing revolutionary in this—it fits naturally into the current approach which, following the well-known formula of Decroly, wants school to use life as a preparation for life. If the children of today are to be able to stand up to tomorrow's audio-visual assault, the techniques involved must cease to be mysterious and esoteric. This can best be done by accustoming children to handle these techniques themselves. The child will feel that his own views have been enlarged; he will have a proper appreciation of the exceptional qualities of these new machines and, having become familiar with them, will understand them better and cease to hold them in awe. Let us therefore have the courage to think out the problems properly and not be content with a superficial consideration of the pedagogics of audio-visual techniques.

'CLOSED' OR 'OPEN' EDUCATION

In order to give them their proper place, we have, throughout this study, purposely spoken freely of audio-visual techniques or methods as excellent aids for the teacher. Like the language in Aesop, they can be the best of things or the worst, used either for the purposes of authoritarian or dogmatic education, or for an education that is liberal and progressive. Let us examine these two possibilities.

We know how effective the cinema can be, and the preceding analyses have demonstrated the power of suggestion of cinema images. Audio-visual techniques can become the instrument of undesirable intellectual and moral conditioning, all the more dangerous because powerful and because the individual is henceforth disarmed. We stressed above the danger of purely passive instruction which may develop blind obedience and submission in the child and smother the initiative which is necessary to his intellectual development. This is the real core of the problem; are audio-visual techniques merely to be teaching aids or, on the contrary, can they be harmoniously integrated into a valid educative process?

Experience has shown that the facilities provided by modern techniques (tape recorders, records, films) in the acquisition of basic knowledge, in apprenticeship in the most exact sense of the word, are important; this is confirmed by the results of using various equipment for teaching purposes, and the writings of Skinner (194) are eloquent in this regard. It is even conceivable that, in the not too distant future, the building up of automatisms and all purely mechanical acquisitions of knowledge will be looked after by machines. But it is inconceivable that education in the broadest and best sense of the word can be simply a matter for machinery. This is not a contradiction of the preceding sentence; it is a recognition of the limitations of mechanical instruction. Audio-visual techniques can be dangerous if man is not the measure of their pedagogical objectives, and the brave new world of Aldous Huxley is an eloquent warning of what a world of robots would be like.

This in itself, however, is no reason for excluding audio-visual aids when they can contribute to a more broad-minded and liberal education. The use of the machine in teaching is valid to the extent to which it enables the teacher to devote more time to his real function of educating. The tape-recorder is a particularly effective self-corrector and has wonderful possibilities for active teaching such as group discussions before or after a specific study.

Seen in that light, audio-visual aids are one of the great modern educational advances, a link between school and ordinary life.

THE FREEDOM OF THE TEACHER

The general educational considerations would not be complete without mention of a problem which is often the subject of very

lively discussion in educational circles—the freedom of the teacher. The utilization of audio-visual techniques, it is alleged, turns the teacher into a robot whose only function is to serve as the link between the producer of the aids and the child; the real teacher is the originator of the audio-visual message, and in the class the teacher has simply to work the magic box which produces all that the children have to learn. What of such allegations? What reply have we?

It may first be pointed out that this censorious attitude is nothing new. In the history of teaching, every new technique has given rise to gloomy predictions of the most appalling catastrophes. Writing, which we now could not do without, was suspect in the Middle Ages. So was the book, as is shown by this quotation from Aries (10):

It is easy to imagine, in the Middle Ages, a lay culture, fed by public reading, recitation, music, with writing being unusual and more or less reserved for clerics. So, for this culture, before printing, and no doubt also because paper was so scarce, recourse was had much more often than today to memory: things had to be known by heart, and writing seemed a suspicious way of avoiding the effort. The theology student was not allowed to have a Bible during his first year, and the master was forbidden the use of notes during his lectures—an additional assurance that he knew his subject by heart, the only certain way to knowledge.

This quotation reflects an attitude rather similar to that which we are discussing in relation to audio-visual techniques. When books appeared and illustrations began to liven up textbooks, when illustrations became commonplace, censorious voices regularly spoke out to condemn *a priori* this intrusion of technology in education.

The same thing happened when audio-visual aids appeared and a new whipping boy was found: the teacher had lost his freedom. The same objection had been made when printing improved and school textbooks began to circulate. Do teachers lose their freedom by drawing upon and using school textbooks? Their complete responsibility remains, and the lesson, can and should retain the personal stamp of the teacher. The same applies to the audio-visual aid. It is at the teacher's disposal: it is he who will decide how, when, and for what purpose it is to be used.

It can be objected that the book is more flexible in that its use can be easily limited or diversified, something that does not apply

202 *Conclusions*

to the film. This is to ignore the fact that a projector can be stopped, that the film is flexible and can be shown in parts; it is to refuse, unreasonably, to admit that a filmstrip is as easy to handle as a photograph album.

Documents are being standardized, for economic reasons, of course, but also because of considerations of technical quality. The teacher is always free to use in his own way and for his own teaching purposes the document offered to him. The preparation for a radio or television broadcast and the use made of it will vary from class to class, and one loses nothing by accepting the line it follows since, at any moment, one can depart from it. The double operation involved in preparing the audio-visual document (by the producer) and using it (by the teacher) is exactly the same as in the case of a book. The real point at issue is the training the teacher must have if he is to know how to utilize what is offered to him.

TRAINING OF TEACHERS

In this matter the training of the teacher must not in any circumstances be limited to an introduction to the handling of audio-visual techniques. As was repeatedly stated above, these techniques, to be fully valid, must be integrated into a more general educational system, and they cannot be properly used until the teacher has had a general training in psychology and teaching theory. One way of training would be to use these techniques during the actual teacher training, and this leads us to take a quick glance at the specific contribution of these techniques to psychology and teaching theory.

A. The teaching of psychology

(1) *Illustration of a course.* In psychology even the most brilliant lecture cannot fully describe a process: the analysis imposed by the lecturer more or less distorts the total picture to be presented even in the case of relatively simple motor behaviour. A lecture on a child's first attempts to walk is transformed as soon as advantage can be taken of the films of Gesell which analyse the different stages through which the child passes between 5 and 6 months and between 14 and 15 months. In this case it might be objected that direct observation is often possible: a visit to a nursery is more illuminating than the film. The objection is valid, but the real gain is often offset by a waste of valuable time, and, all in all, the balance is in favour of the film.

Neither must it be forgotten that the illustration of the lecture can be given on the spot (it suffices to have arranged to have the film available), whereas direct observation cannot be arranged at will. Certain emotive reactions which embody a general idea cannot always be obtained with children; the film will always provide, when asked, what is wanted of it.

(2) *Better observation.* In the preceding case it may have been necessary to put forward certain arguments to tilt the balance in favour of the film, but this will not be necessary here. The film or tape recorder not only permits but undoubtedly improves students' observation of a psychological phenomenon which is to be explained to them.

The simple possibility of reproduction is of major interest in psychology. In the most favourable circumstances the reaction of a child can be demonstrated, but it is almost always impossible to reproduce it at will—Heraclitus has had the last word: "We never bathe twice in the same stream." Students do not see, the first time, what is to be shown to them, for the simple reason that many of the exact observations required can be made only by experienced psychologists; our rôle is to help train the student in this. There are, for example, many things to be noted in a very simple piece of behaviour, and it has to be seen several times before these observations can be exhaustively made. With the help of his students, Gesell succeeded in describing, week by week, the appearance or disappearance of extremely fine shades of behaviour which pass unnoticed during a first observation.

Here it is easy to imagine what the pedagogical technique will be. Let us take, for example, the utilization of the film *Études de comportement (La Boîte de Decroly)*, "Behaviour Studies (Decroly's Box)". A case can be shown to students, and the projection then stopped. Each notes what he has seen. During a second projection the first observations can be clarified and any inaccuracies eliminated. This serves two purposes simultaneously: it provides psychological knowledge and it trains observation. The professor who is completely familiar with the film also has the advantage that he can get to know his students by observing their reactions during the film—the rapidity, reliability, and accuracy of the observations they make.

The comparison of different types of behaviour thus enriches simple observation, and it is, amongst other reasons, because the psychologist has a great deal of experience that he can judge better.

Those who know the film referred to above can easily see that the simple juxtaposition of cases was done in such a way as to make the main features of each stand out more clearly; it is in relation to the excited state that inhibition becomes fully apparent; the ordered behaviour of the child cannot really be apprehended except in relation to typical trial-and-error behaviour. In a minimum of time and with maximum efficiency, therefore, the film can illustrate different cases—because they are known beforehand—much better than could be done by having a simple succession of actual cases.

Reference should also be made to a last element which only modern recording techniques can provide—the ability to slow down or speed up behaviour. Prudhommeau's films on drawing offer an excellent example of the advantages provided by a slow-motion examination of a gesture through which both the general movement and the complexity of it can be simultaneously studied. The slow-motion film of Matisse painting his grandson shows us the number of micro-movements involved, and through this we can graphically translate what the painter himself felt during the creative act. Such exercises in observation accustom the teacher not to be satisfied with too general a view of a gesture, an attitude, or a type of behaviour, but to go deeper into the analysis with a view to obtaining a better interpretation.

(3) *Time condensation.* It is sometimes impossible to observe a phenomenon if it lasts too long, and here the film or tape recorder is indispensable. How can we make a precise study of the transformations which take place in a child's language without recording on tape entire periods during which the child tries out the language? Once during the holidays I recorded the way in which one of my daughters, then a year old, asked for something to drink. It was fascinating to listen to various recordings of periods of a few seconds each and find oneself able to follow with extraordinary precision the development of articulation, the progressive adjustment of the syllables until the child got some word completely right. Parents normally forget; this can be overcome by a recording, which alone permits such analyses to be made.

Psychological determinism is such that any hypothesis of linear evolution must be rejected. Phenomena appear and then disappear, to turn up once again in a new structure. Without introducing any more or less metaphysical idea of finality, it can be said that present behaviour cannot really be understood without reference to the place it will have in the future psychological structure. The

film allows psychologists under training to take advantage of the experience of practitioners who can show on film aspects of conduct which do not appear clearly to the inexperienced observer. Here the film deforms in order to illustrate better. It is scarcely necessary to say that this systematic deformation should not go beyond certain limits.

Taking it from another point of view, the comparison can relate to the successive reactions of the same child to similar periodically recurring situations.¹ The same gesture of a child smelling a rose, filmed every month over a fairly long period; the attitudes of a child before a mirror, filmed day by day; the daily recording of a child's language at the same time and in the same situation, provide ways of showing students both the child's general development and the particular development of his body, behaviour, or attitudes.

Thanks to this condensation of time, the film can provide opportunities for studying the complete development of personality better than a file, which must necessarily always be somewhat static. In the Canadian film *Aggression* (115), for example, it is made very clear how the successive events in the life of a child (loss of father, exclusive attachment to the mother, the mother's remarriage, the birth of a baby brother, arrangements about schooling, and so on) operate in the formation and deformation of the personality of a girl who, despite the appearance of having been successful in life, had not achieved the personal happiness to which she seemed entitled.

Students' comments on such films provide an excellent introduction to lectures which will demonstrate the necessity of having a great deal of data in the psychological file. Apart from the specific techniques used (test, projection tests, and so on), a type of intuition is developed in the future psychologist that is based on a comprehensive sympathy which can bring the widely scattered elements of a dossier together.

(4) *Where observation is impossible.* Sometimes the film offers the only possibility of introducing students to experiments or cases which are interesting from the psychological point of view. Firstly, psycho-pathological cases often cannot be observed by non-medical students. This difficulty can be overcome by a film like that of

¹ Information about Decroly's use of film techniques can be found in J. E. Segers' book *La psychologie de l'enfant normal et anormal d'après le Dr O. Decroly* (Delachaux et Niestlé, 1948), pp. 7-11.

Lebovici. Secondly, there is animal psychology, where demonstrations often have to be prepared a long time beforehand; the psychology professor who has not specialized in this matter cannot provide his students with interesting typical experiments—*e.g.*, on learning to run a maze, or certain types of social behaviour. Thirdly, there is the unusual experiment—*e.g.*, that carried out by the Kellogs, who reared a young monkey with their own son, in precisely similar conditions. The films made by the parents were not technically perfect, but are of the greatest psychological interest and offer a remarkable illustration at all points “of animal intelligence in relation to child intelligence and the relations between animal and man”.

There is also the possibility of making recordings unknown to the subject. Certain types of behaviour never occur in the presence of a psychologist, but do if the subject thinks he is alone and is not being observed. Behind a wall from which he could see without being seen Gesell was able to film the reactions of children who put on an act when their parents or teachers were present, but revealed their true selves when they thought they were alone. The producers of a comic programme recently filmed (without being seen) passers-by who found in their path a ten-franc note which had previously been stuck to the ground in a very busy street. The film is both curious and interesting, sometimes showing the conflict between the desire to take the money and the fear of being seen by others; in some of the passers-by, these hesitations resulted in a curious ballet performed backward and forward around the discovery.

Films in the training of psychologists. The utilization of films for training observers was referred to above. The film can, however, go much farther in regard to psychological training. Observation is not just a simple photographing of reality. Budding psychologists have to be shown and to accept the fact that it is impossible to eliminate personal interpretation entirely. In no case can the witness be entirely neutral; his perceptive, intellectual reaction is one with his personality. Objectivity consists in taking due account of this element of interpretation, this personal equation which inevitably distorts psychological reality. This acquisition of awareness is as useful to the practising psychologists as it is to the teacher, since the distortion also operates in some degree in the relations between student and professor.

Films presenting ambiguous subjects, the observation of which will vary according to the general hypothesis held by the observer, are very effective in the training of future psychologists and future educators. In our courses we have used the excellent experimental films of Cohen-Seat, designed to allow the detailed study of perceptual and projective phenomena. The discussion during which each student defended his own interpretation marked a turning-point in their attitude to psychological phenomena; it seemed very clear that their clinical sense had suddenly progressed and that at least some of them had understood what the search for explanatory hypotheses in psychology really involved.

We have not spoken of the contribution of the filmstrip and film in the student's initiation to psychological techniques. Some years ago we made a filmstrip on the Grace Arthur test, and so were able to show the different stages in the application of the test to a large group. The audio-visual technique made no specific contribution of its own—it might even be held that its very ease of use could be dangerous for the psychologist in that it too easily replaced the necessary contact with his students. Compared with the necessity for creating a favourable attitude for the test, the actions to be learned are of comparatively minor importance. Here the use of films may give rise to illusions about the level of training attained.

Despite the limitations we have been obliged to point out concerning the use of audio-visual aids in the teaching of psychology, we can, nevertheless, conclude in a general way that their contribution is positive. It may not be possible to teach all about psychology by means of films, and the training involved requires contacts other than those provided by the screen, but recourse to recording and reproduction techniques in teacher-training colleges and in the psychological departments of all advanced training schools is something that is only to be encouraged.

B. The teaching of educational theory and methods

To the extent to which training in education requires a minimum of psychological training if the teacher is to know, understand, and help pupils, the utilization of audio-visual techniques in psychology and education brings certain common problems. There are, however, certain basic differences which almost make it necessary to deal with the two questions in separate chapters. The film allows

the student to play the rôle of psychologist-observer, and the way in which certain aspects of the training of these trainees could be directly carried out was indicated above. The teacher has an active rôle to play; he must work on real pupils in a definite scholastic situation. Audio-visual techniques can therefore be widely used in providing information, both theoretical and practical; but the practical training of future educators—*i.e.*, the transformation of a spontaneous attitude into a properly adapted and efficient pedagogical behaviour—cannot, for the most part, really be made except in the class, in a specific situation. From this it will be seen that there is a basic difference in the utilization of audio-visual techniques in the training of psychologists and in the training of teachers. The teacher's main function is to act on his pupils, to create a certain atmosphere, to guide their behaviour towards learning and growth; in other words, the attitudes of a spectator and those of a teacher are in opposition.

That is not to say, however, that the film has no rôle to play in training teachers.

1. *General motivation.* It is interesting to outline to future teachers the ideal training it would be desirable to give them, and thereby explain the reason for all the exercises they undertake whose point they may not immediately understand. The film makes it possible to provide valuable documentation about the virtues and defects of our own teacher training. It is always profitable to be able to make a comparison between what occurs in one's own country and what is done abroad. Here we have particularly in mind an American film we have often used to advantage. The point is not to make a value judgment on teacher training, but to take advantage of certain sequences which may explain to the newcomer some of the difficulties of the profession he is about to learn, the obstacles he may have to face, and the personal satisfaction he will know when his competence as a teacher and generosity as a person have found their true outlet. The general impression the film gives is extremely stimulating, and it underlines the major points of importance in teacher training.

2. *General educational information.* It is difficult to see what contribution the film can make to the philosophical problems raised by education; certain institutions can be depicted only with difficulty. A film can render the atmosphere and structure of a school system, but no-one will deny that it is limited in this respect.

Once we shift to general methods, the audio-visual contribution

becomes more important. The illustration by a film made at the *Hermitage School in Brussels (150)* of a course on the Decroly method is indispensable if students who will never go to Belgium are to have a clear and exact picture of this great Belgian pedagogical school. The same could be said about films on the Freinet method in France. In this regard audio-visual techniques have exactly the same rôle to play as they have in other disciplines.

3. *Special technical information.* We feel, on the other hand, that the well-designed film can make a vital contribution to teacher training. For obvious technical reasons it is usually impossible to make a juxtaposition of several demonstration experiments. With the film this difficulty can be overcome. Let us take the example of a mathematics lesson in a second-year class. A lesson given by a teacher can be filmed, but it is not very easy to see how this in any way improves upon the ordinary course of following the lesson in the actual class.

But now let us imagine the same lesson being given in a very different way to pupils. The main features of each of the methods used will appear clearly, and the educational effect is greater. Take, for example, the classic theorem about the sum of the angles of a triangle. The explanation could be given in at least five ways (no judgment value will be given here, nor is it implied that there are no other ways of presenting the matter).

1. The classical dogmatic method. The teacher gives a very precise demonstration of the theorem; the effect is to show clearly how even an excellent lesson can simply leave the pupils more passive than they were before.
2. The dogmatic method, but one which induces reflection and pupil co-operation. The plan followed has been prepared by the teacher, and the questions he asks (which give an appearance of activity to the class) provide a semblance of pupil participation.
3. Concrete verification as a motive for making the demonstration (see No. 5 below). The angles of a triangle are cut off and actually added together.
4. 'Statistical' verification of the properties. Each pupil, protractor in hands, calculates the sum of the angles. The average of the measurements obtained by the various pupils is very close to 180° .
5. The pupils have already been 'motivated' (see methods 3

and 4). How can we now prove this property which has often been noted? The search for such a proof here represents a really active method.

A film made to the above simplified scenario would give rise to very interesting discussions, and many problems on the teaching of mathematics would be touched upon. In the minimum time future teachers would be able to see many specific examples in a way which could never be done by a school visit, however well organized.

The teacher of psychology and education must himself adopt the behaviour he recommends to his students; his critical spirit always awake, he must remain alert to what life brings, to technical progress, to new methods and procedures. His objective examination of the contribution of audio-visual aids to psychological training and to the preparation of teachers for their work can only result in an encouraging and favourable report. Avoiding fashion with the same care as he avoids a slavish conformity to tradition, the teacher must decide what will lead to efficiency in widening his pupils' horizons in the minimum of time, in developing what they have assimilated, and in guiding the personal reactions which give each pupil's education its own particular stamp.

THE MAKING OF AUDIO-VISUAL MATERIALS

The reader will have no difficulty in understanding that the production of audio-visual aids for teaching purposes cannot be a purely technical or commercial matter. Effective equipment cannot be designed and made without taking account of the various educational and psychological points included in this study. Additionally, we must eliminate materials which might cause traumatic effects amongst pupils, and we must never forget the psychology of our spectators. These considerations have led experts to hope that audio-visual materials will be prepared by teams in which there will be close collaboration between cinema and sound technicians and educational psychologists.

This submission to the laws of psychology as known at present does not necessarily amount to stability; on psychological grounds new forms must be sought such as using productions made by the children themselves in order to ensure better comprehension.

In any case the experimental attitude should take precedence over commercial considerations. The utilization and production of

audio-visual aids is now inconceivable without an educational research laboratory, through which the quality of such aids can be constantly improved.

Having now come to the end of this effort to group our present knowledge and explain some of the problems which are of importance for the educational psychologist, we can see the extent and importance of the gaps we have left. There are many questions which it has not been possible to answer. Here and there we have selected problems which have appeared important—a process not without embarrassment to us, since, like the philosopher, we have found that to choose is to renounce. In order to remain within the limits set, we have had to eliminate, to summarize, and to shorten. We have tried neither to distort nor to misrepresent the thoughts of the authors to whom we have referred, but we have been conscious of the immensity and the enormous number of the problems raised by the introduction of audio-visual aids in schools. If we are not to be overcome by these problems we must master them, and if we are to master them we must know.

We have attempted to bring together data and reflections with a single object in view: that of helping teachers to do their work better, so that the children of tomorrow will be better than the children of today.

BIBLIOGRAPHY

1. *Actes du Congrès international sur la presse périodique, cinématographique et radio pour enfants, Milano, 19-23 mars 1952* (Milano, A. Giuffrè, 1953, 329 pp.).
2. ADCOCK, C. J., QUARTERMAIN, D., and ARVIDSON, G. L.: "How effective is subliminal stimulation?" (*Australian Journal of Psychology*, vol. 11, 1959, pp. 135-139).
3. ALBERTINI, L. and CARUSO, A. P.: "Percezione e interpretazione di immagini cinematografiche nei ragazzi" (*Bianco e nero, Roma*, vol. 10, 1949, pp. 9-27).
4. ALLEN, W. H.: "Audio-visual communication research" (*Journal of Educational Research*, vol. 49, 1946, pp. 321-330).
5. —: "Research on film use: class preparation" (*Audio-visual Communication Review*, vol. 3, 1955, pp. 183-196).
6. ALLISON, S. G. and ASH, P.: *Relationship of anxiety to learning from films* (Port Washington, N. Y., Office of Naval Research, Special Devices Center, 1951, 15 pp., Technical report No. SDC 269-7-24).
7. ALLPORT, F. D.: *Theories of perception and the concept of structure* (New York, Wiley, 1955, 709 pp.).
8. ALTAVILLA, E.: "Film di gangster e riflessi psicologici sui fanciulli" (*Bianco e nero, Roma*, vol. 10, 1949, pp. 45-49).
9. ANDERSON, N. S. and FITTS, P. M.: "Amount of information gained during brief exposures of numerals and colours" (*Journal of Experimental Psychology*, vol. 56, 1958, pp. 362-369).
10. ARIES, P.: *L'enfant et la vie familiale sous l'ancien régime* (Paris, Plon, 1960, 502 pp.).
11. ARNSIGER, V. C.: *Measuring the effectiveness of sound pictures as teaching aids* (New York, Columbia University, Teachers College, 1933, 156 pp.).
12. ASH, P.: *The relative effectiveness of massed versus spaced film presentation* (Port Washington, N. Y., Office of Naval Research, Special Devices Center, 1949, 19 pp., Pennsylvania State College, Instructional Film Research Program, Technical report No. SDC 269-7-3).
13. — and CARLTON, B. J.: *The value of note-taking during film learning* (Port Washington, N. Y., Office of Naval Research, Special Devices Center, 1951, 10 pp., Technical report, No. SDC 269-7-21).

14. — and JASPEN, N.: *Optimum physical viewing conditions for a rear projection daylight screen* (Port Washington, N. Y., Office of Naval Research, Special Devices Center, 1953, 17 pp., Pennsylvania State College, Instructional Film Research Program, Technical report No. SDC 269-7-37).
15. ATTNEAVE, F.: "Some informational aspects of visual perception" (*Psychological Review*, vol. 61, 1954, pp. 183-193).
16. —: *Applications of information theory to psychology* (New York, Holt-Dryden, 1959).
17. BAILYN, L.: *Mass media and children: a study of exposure habits and cognitive effects* (Cambridge, Mass., Centre for International Studies, Massachusetts Institute of Technology, 1958, 41 pp., Multigraph).
18. BARTLEY, S. H.: *Principles of perception* (New York, Harper, 1958, 482 pp.).
19. — and DEHARDT, D. C.: "A further factor in determining nearness as a function of lateral orientation in pictures" (*Journal of Psychology*, vol. 50, 1960, pp. 53-57).
20. BATTRO, A. M. and FRAISSE, P.: "Y a-t-il une relation entre la capacité d'appréhension visuelle et le mouvement des yeux?" (*Année psychologique*, vol. 61, No. 2, 1961, pp. 313-324).
21. BEHRINGER, G.: "Welche Rolle spielt der Film tatsächlich im Leben unserer Jugend? 16,000 Wiener Jugendliche geben Antwort" (*Oesterreichischer Jugend-Informationsdienst*, 1954, No. 7, 9/10, pp. 4-6).
22. BELLINGROTH, F.: *Triebwirkung des Films auf Jugendliche. Einführung in die analytische Filmpsychologie auf Grund experimenteller Analysen kollektiver Triebprozesse im Filmleben* (Bern, H. Huber, 1958, 154 pp.).
23. BJERSTEDT, A.: "'Routine-blockade', experiments in perception, pro-expectational distortion and more general cognitive characteristics" (*Scandinavian Journal of Psychology*, vol. 1, 1960, pp. 19-26).
24. BLACKWELL, H. R.: "Comments on 'subliminal projection'" (*Journal of Communication*, vol. 8, 1958, pp. 68-76).
25. BLAIN, B. B.: *Effects of film narration type and of listen-ability level on learning of factual information* (Doctoral thesis, Bloomington, Indiana University, 1956, 297 pp.).
26. BLUMER, H.: *Movies and conduct* (New York, Macmillan, 1953, 257 pp., Payne Fund studies No. 205).
27. BORING, E. G.: *Sensation and perception in the history of experimental psychology* (New York, Appleton, 1942, 644 pp.).
28. BOURJADE, J.: *L'intelligence et la pensée de l'enfant* (Paris, Presses Universitaires de France, 1942, 161 pp.).
29. BRANDT, H. F. Y.: *The psychology of seeing* (New York, Philosophical Library, 1945, 240 pp.).
30. BRANDT, H. P.: "The psychology of seeing motion pictures" (in Elliot, G. M.: *Film and education*, pp. 39-54, New York, Philosophical Library, 1948).

214 Bibliography

31. BRINKMANN, D.: "Zur Psychologie des Jugendfilms" (*Der Psychologe*, 1953, No. 5, pp. 89-93).
32. —: "Jugend und Film" (*Reformierte Schweiz, Pfäffikon, Zürich*, 1956, No. 11, pp. 400-403).
33. BROADBENT, D. E.: *Perception and communication* (New York, Pergamon Press, 1958, 338 pp.).
34. BROWN, H. S. and NESSERSMITH, L.: "An experiment in teaching tumbling with and without motion pictures" (*Research Quarterly*, vol. 19, 1948, pp. 304-307).
35. BRUNER, J. S.: "Neural mechanisms in perception" (*Psychological Review*, vol. 64, 1957, pp. 340-358).
36. —: "On perceptual readiness" (*Psychological Review*, vol. 64, 1957, pp. 123-152).
37. BRUNSWIK, E.: *Perception and the representative design of psychological experiments* (Los Angeles, University of California, 1956, 154 pp.).
38. BUSWELL, G. T.: *How people look at pictures* (Chicago, University of Chicago Press, 1935, 198 pp.).
39. CANESTRELLI, L.: "Psicologia e films—Problemi psicologici, etico-psicologici, psico-pedagogici" (*La difesa del ragazzo*, Roma, vol. 25, No. 5, 1956, pp. 219-238).
40. CANTRILL, H.: "Concerning the nature of perception" (*Proceedings of the American Philosophical Society*, vol. 104, 1960, pp. 467-473).
41. CARPENTER, C. R.: "Psychological concepts and audio-visual instruction" (*Audio-visual Communication Review*, vol. 5, 1957, pp. 361-369).
42. CARREL, A.: *L'homme, cet inconnu* (Paris, Plon, 1954, 416 pp.).
43. CARROLL, J. B.: *The study of language* (Cambridge, Mass., Harvard University Press, 1953, 289 pp.).
44. CENTRE DE RECHERCHE ET D'ÉTUDE POUR LA DIFFUSION DU FRANÇAIS, Paris: *Voix et image de France* (Paris, Didier, 1961).
45. CHARTERS, W. W.: *Motion pictures and youth: a summary* (New York, Macmillan, 1934, 66 pp., Payne Fund studies).
46. CHAUCHARD, P.: *Précis de biologie humaine. Les bases organiques du comportement et de la pensée* (Paris, Presses Universitaires de France, 1957, 403 pp.).
47. —: *Le cerveau et la conscience* (Paris, Éditions du Seuil, 1960).
48. CHRESTA, H.: *Moderne Formen der Jugendbildung: Literatur, Film, Radio, Fernsehen* (Zürich, Artemis-Verlag, 1958, 199 pp.).
49. CHURCH, J. G.: *A survey of literature bearing on perceptual aspects of the effectiveness of visual aids* (Washington, D. C., Bolling Air Force Base, Human Resources Research Laboratories, 1952, 20 pp., Memo report No. 16).
50. CLOSTERMANN, G. and PREUSS, K.: *Abhandlungen zur*

- Jugend-Filmpsychologie* (Münster, Aschendorfsche Verlagsbuchhandlung, 1952, 47 pp.).
51. COGSWELL, J. F.: *Effects of a stereoscopic sound motion picture on the learning of a perceptual-motor task* (Port Washington, N. Y., Office of Naval Research, Special Devices Center, 1952, 13 pp., Pennsylvania State College, Instructional Film Research Program, Technical report No. SDC 269-7-32).
 52. COHEN-SEAT, G.: "Filmologie et cinéma" (*Revue internationale de filmologie*, 1948, No. 3-4, pp. 237-247).
 53. — and FAURE, J.: "Retentissement du 'fait filmique' sur les rythmes bioélectriques du cerveau" (*Revue internationale de filmologie*, vol. 5, 1954, pp. 27-50).
 54. —, GASTAUT, H., and BERT, J.: "Modification de l'EEG pendant la projection cinématographique" (*Revue internationale de filmologie*, vol. 5, 1954, pp. 7-26).
 55. —, LELORD, G., JAMPOLSKY, R., and LAUZEL, J. P.: "Film, EEG, Rorschach, réactions psychophysiologiques et problèmes de personnalité" (*Revue internationale de filmologie*, vol. 10, 1960, pp. 32-33).
 56. DALE, E., *et al.*: "Research on audio-visual materials" (in National Society for the Study of Education, 48th Yearbook, part I, pp. 253-293, Chicago, University of Chicago Press, 1949).
 57. —, FINN, J. D., and HOBAN, C. F.: "Visual education" (in W. S. Monroe (ed.): *Encyclopedia of Educational Research*, pp. 84-97, revised edition, New York, Macmillan, 1960).
 58. DEININGER, R. L. and FITTS, P. M.: "Stimulus-response compatibility, information theory and perceptual-moto performance" (in Quastler, H.: *Information Theory in Psychology*, Glencoe, Illinois, Free Press, 1955, 435 pp.).
 59. DE KIEFFER, R. E.: *The status of teacher-training in audio-visual education in forty-eight states* (Doctoral thesis, Ames, Iowa State University, 1948).
 60. DIAZ-PLAJA, G.: *Cine y adolescencia en "El arte de quedarse solo y otros ensayos"* (Barcelona, Juventud, 1936).
 61. DREHER, J. J. and O'NEILL, J. J.: "Effects of ambient noise on speaker intelligibility for words and phrases" (*Journal of the Acoustical Society of America*, vol. 29, 1957, pp. 1320-1328).
 62. DWORKIN, S. and HOLDEN, A.: "An experimental evaluation of sound filmstrips vs. classroom lectures" (*Journal of the Society of Motion Picture Engineers*, vol. 68, 1959, pp. 383-385).
 63. EMERY, F. E.: "Psychological effects of the western film: a study in television viewing. I. The theoretical study: working hypotheses on the psychology of television" (*Human Relations, London*, vol. 12, 1959, pp. 195-213).
 64. ENOCH, J. M.: "Effects of the size of a complex display upon visual research" (*Journal of the Optical Society of America*, vol. 49, 1959, pp. 280).
 65. EPSTEIN, W. and ROCK, I.: "Perceptual set as an artefact of

- receiving" (*American Journal of Psychology*, vol. 73, 1960, pp. 214-228).
66. EVANS, R. M.: *Eye, film and camera in color photography* (New York, Wiley, 1959, 410 pp.).
 67. FEARING, F.: "Toward a psychological theory of human communication" (*Journal of Personality*, vol. 22, 1953, pp. 71-88).
 68. FIELD, M.: *Children and films. A study of boys and girls in the cinema* (Edinburgh, Carnegie United Kingdom Trust, 1954, 56 pp. + annexes).
 69. *Film i omladina* (Conférences et discussions tenues les 2, 4 et 5 décembre à Novi Sad. Beograd, Novi Dani, 1957, 229 pp.).
 70. FINN, J. D.: "Direction in audio-visual communication research" (*Audio-visual Communication Review*, vol. 2, 1954, pp. 83-102).
 71. —: "A look at the future of A. V. communication" (*Audio-visual Communication Review*, vol. 3, 1955, pp. 244-256).
 72. —: "Automation and education. Part I: General aspects" (*Audio-visual Communication Review*, vol. 5, 1957, pp. 343-360).
 73. —: "Automation and education. Part II: Automatizing the classroom. Background of the efforts" (*Audio-visual Communication Review*, vol. 5, 1957, pp. 451-467).
 74. FLIK, G.: "Untersuchungen über den Einfluss des Films auf kriminell gewordene Jugendliche" (*Psychologische Rundschau*, vol. 6, No. 1, 1954, pp. 1-21).
 75. FORD, A., WHITE, C. T., and LICHTENSTEIN, N.: "Analysis of eye movements during free search" (*Journal of the Optical Society of America*, vol. 49, 1959, pp. 287-292).
 76. FORD, R.: *Children in the cinema* (London, Allen and Unwin, 1939, 240 pp.).
 77. FRAISSE, P. and BATTRO, A.: "L'évolution de la capacité d'appréhension en fonction du temps d'exposition" (*L'année psychologique*, vol. 60, 1960, pp. 295-307).
 78. —, OLERON, G. and PAILLARD, J.: "Les effets dynamogéniques de la musique. Étude expérimentale" (*L'année psychologique*, vol. 53, 1953, pp. 1-33).
 79. FRANCE.: "Association nationale du cinéma pour l'enfance et la jeunesse" (*Le cinéma et les enfants*, Paris, 1950, 48 pp.).
 80. FREEMAN, J. and NEIDT, C. O.: "Effect of familiar background music upon film learning" (*Journal of Educational Research*, vol. 53, 1959, pp. 91-96).
 81. FRENCH, J. E.: "Children's preferences for pictures of varied complexity of pictorial pattern" (*Elementary School Journal*, vol. 53, 1952, pp. 90-95).
 82. FREOUR, P., SERISE, M., COUDRAY, P., and HUDSON, W.: "La possession par le film: préliminaire à une étude psychologique du cinéma" (*Hygiène mentale*, 1959, No. 48, pp. 289-302).
 83. FULCHIGNONI, E.: "Filmologie et psychologie infantile" (*Revue internationale du cinéma*, 1949, No. 4, pp. 38-41).

84. —: "Cinéma et psychologie" (*Revue de psychologie appliquée*, 1951, No. 1, pp. 61–68).
85. GARRIDO LESTACHE, J.: *La infancia y el cinematógrafo* (Madrid, Dirección General de Sanidad, 1940, 20 pp., Al servicio de España y del niño español, 34).
86. GASTAUT, H. and ROGER, A.: "Effets psychologiques somatiques et électroencéphalographiques du stimulus lumineux intermittent rythmique" (*Revue internationale de filmologie*, vol. 2, 1951, pp. 215–229).
87. GEL'MONT, A. M.: *Sudenie detskovo kinozriteja* (Moskva, Roskino, 1933, 64 pp.).
88. GEMELLIA, A.: "Cinema e psicologia" (*Vita e pensiero*, vol. 11, 1949, pp. 591–596).
89. GERHARTS-FRANCK, I.: *Über Geschehensgestaltungen in der Auffassung von Filmen durch Kinder* (Leipzig, J. A. Barth Verlag, 1955, 124 pp.).
90. GIBSON, J. J.: *The perception of the visual world* (New York, Houghton, 1950, 235 pp.).
91. —: "A theory of pictorial perception" (*Audio-visual Communication Review* vol. 2, 1954, pp. 3–23).
92. GIRAUD, J.: "La jeunesse et le cinéma" (*Bulletin de l'École pratique de psychologie*, 1954, Nov.–Dec., pp. 104–108).
93. —: *Il cinema e l'adolescenza* (Roma, Ed. Avio, 1958, 519 pp.).
94. GLASTRA VAN LOON, G. H.: "Speelt de film bij het verloop van psychosche stoornissen van het kind een rol?" (*Maandblad voor de geestelijke Volksgezondheid*, vol. 10, No. 2, 1955, pp. 62–72).
95. GONÇALVES, S.: "Considerações sobre a criança e o cinema" (*Briança, Rio de Janeiro*, vol. 2, 1943, pp. 137–146).
96. GOYER, R. S.: "Oral communication: studies in listening" (*Audio-visual Communication Review*, vol. 2, 1954, pp. 263–276).
97. GRAY, B.: "Enfants et adolescents devant les films" (*Revue internationale de filmologie*, vol. 3, 1952, pp. 193–210).
98. GREIMAS, A. J.: "Observation sur la méthode audio-visuelle de l'enseignement des langues vivantes" (*Études de linguistique appliquée*, No. 1, 1962, pp. 137–155).
99. HARRIS, C. W. and BUENGER, L. R.: "Relation between learning by lecture" (*Audio-visual Communication Review*, vol. 3, 1955, pp. 29–34).
100. HART, W. A.: "Een inleidend onderzoek tot het probleem film en jeugd" (*Nederlands Tijdschrift voor de Psychologie en haar grensgebieden*, vol. 2, 1953, pp. 163–200).
101. HAVE, T. T. TEN.: *Speelfilms in de belebingsvereld van jeugdigen* (Purmerend, Muusses, 1956, 246 pp.).
102. HEINRICH, K.: "Traumfabrik und Jugend-Träume. Eine Film-psychologische Studie" (*Film, Bild, Ton*, 1953, No. 6, pp. 221–227; No. 7, pp. 258–264).

218 *Bibliography*

103. —: *Bibliographie: Film und Jugend* (Frankfurt am Main, Hochschule für internationale pädagogische Forschung, 1959, 269 pp. Multigraph).
104. HELIER, D.: "Kind en bioscoop de juiste verhouding" (*Het Kind, Bruxelles*, 1952, No. 1, pp. 31-44).
105. HENRY, N. B. (ed.): *Mass media and education* (National Society for the Study of Education, 53rd Yearbook, part II, Chicago, University of Chicago Press, 1954, 290 pp.).
106. HEUYER, G.: "Influence immédiatement décelable du film à partir de 10 ans" (*Rencontre internationale d'experts sur les aspects psychologiques, techniques et sociaux des problèmes du cinéma et de la jeunesse, Luxembourg, 31 mai-4 juin 1955, Genève, Fraternité mondiale*, 1955, 12 pp.).
107. —: "Cinéma et affectivité" (*L'École des parents*, 1955-1956, No. 3, pp. 15-27).
108. —, COHEN-SEAT, G., LEOVICI, S., REBEILLARD, and DAVEAU: "Note sur l'électroencéphalographie pendant la projection cinématographique chez des adolescents inadaptés" (*Revue internationale de filmologie*, vol. 5, 1954, pp. 51-64).
109. — and LEOVICI, S.: "Troubles du caractère et cinéma" (*Psyché: Revue internationale des sciences de l'homme et de psychanalyse*, 1947, No. 11, pp. 1-106).
110. HILLS, J.: *Films and children: the positive approach* (London, British Film Institute, n.d., 59 pp.).
111. HOBAN, C. F.: *Movies that teach* (New York, The Dryden Press, 1946, 189 pp.).
112. —: "Determinants of audience reactions: status" (*Audio-visual Communication Review*, vol. 1, 1953, pp. 242-251).
113. —: "Determinants of audience reaction to a training film" (*Audio-visual Communication Review*, Vol. 1, 1953, pp. 30-37).
114. —: "Research and reality" (*Audio-visual Communication Review*, vol. 4, 1956, pp. 3-20).
115. *Hostilité, 1947-1950*. Film distributed by the Canadian Embassy. Length: 30 minutes. 16 mm. (Mental mechanisms series).
116. HYER, Anna L.: *A study of possible deterrents to use of motion pictures within a school system where films and facilities for use were provided* (Doctoral thesis, Bloomington, Indiana University, 1952).
117. IRGENS, H. R.: *Filmseende och mognad* (Göteborg, 1958, 89 pp.).
118. KANIZSA, G. and METELLI, F.: "Recherches expérimentales sur la perception visuelle d'attraction" (*Journal de psychologie*, 1961, No. 4, pp. 385-420).
119. KEILHACKER, M.: "Die Filmeinflüsse bei Kindern und Jugendlichen und die Problematik ihrer Feststellung" (in Feldmann, E. and Hagemann, W.: *Der Film als Beeinflussmittel...* Emsdetten, Verl. Lechte, 1955, 118 pp.).

120. —: "Le cinéma et les réactions des enfants et des adolescents" (*Cahiers de pédagogie de l'Université de Liège*, 1955, No. 15, pp. 67-75).
121. —: "Fragen der Filmerziehung" (*Zeitschrift für Pädagogik*, vol. 3, No. 4, 1957, pp. 253-270).
122. — and KEILHACKER, M.: *Kind und Film* (Stuttgart, E. Klett, 1955, 55 pp., *Bedrohte Jugend*, 39).
123. KEIR, G.: "Psychology and the film" (*Penguin film review*, London, 1949, No. 9, pp. 67-72).
124. KENDLER, T. S. et al.: *Implications of learning. Theory for the design of audio-visual aids* (Washington, D. C., Bolling Air Force Base, Human Resources Research Laboratories, 1951, 36 pp., Memo report No. 12 A).
125. —: "An investigation of the inter-acting effects of repetition and audience participation on learning from training films" (*American Psychologist*, vol. 8, 1953, pp. 378-379, Analytical summary).
126. KIRK, R. E.: "A major factor influencing preferences for high-fidelity reproducing systems" (*Journal of the Acoustical Society of America*, vol. 28, 1956, pp. 1113-1116).
127. KLAPPER, J. T.: "Studying effects of mass communication" (*Communication and the Communications Arts*, vol. 57, No. 2, 1955, pp. 95-103).
128. LANZ-STUPARICH, M.: *Les adolescents et le cinéma. Recherches préliminaires*. Baumgarten, F.: *La psychologie dans le monde moderne*, pp. 557-561. (Compte rendu du IX^e Congrès international de psychotechnique, Berne, 12-17 septembre 1949, Paris, Presses Universitaires de France, 1952).
129. LEANDRI, F.: "Vos enfants devant le film" (*L'école maternelle française*, 28^e année, 1951, No. 7, pp. 8-12).
130. LEBOUTET, L.: "Étude comparative de la perception du positif sur papier et de l'image fixe projetée sur écran" (*Revue internationale de filmologie*, vol. 4, No. 1-2, 1953, pp. 39-52).
131. —: *Perception d'images fixes dans différentes conditions* (Communication au Congrès international de filmologie, Paris, 1955).
132. LE MOAL, P. and FAUGÈRE, M. M.: "Le cinéma et l'enfant" (*La sauvegarde de l'enfance*, 1947, No. 15-16, pp. 66-77).
133. LEROY-BOUSSION, A.: "Étude du comportement émotionnel enfantin au cours de la projection d'un film comique" (*Revue internationale de filmologie*, vol. 4, 1954, pp. 103-123).
134. —: "Le jeune spectateur et son entourage. Étude des relations inter-individuelles observées chez 22 enfants de 4 à 14 ans au cours de la projection d'un film comique" (*Enfance*, vol. 4, No. 7, 1954, pp. 293-316).
135. —: "De l'inquiétude au rire" (*Enfance*, vol. 5, 1955, pp. 455-483).
136. LEVINE, S.: "The role of motivation in the effects of active

- review on learning from a factual film" (*American Psychologist*, vol. 8, 1953, pp. 388-389, Analytical summary).
137. LITT, TH.: *Leitfaden der Psychologie* (Leipzig, Engelmann, 1906, 324 pp.).
 138. LUNDERS, L.: "Comment évaluer l'influence du cinéma sur les enfants?" (*Revue internationale du cinéma*, vol. 4, No. 12, 1952, pp. 50-55).
 139. LUXENBURGER, H.: "Psychiatrische und Heilpädagogische Fragen des Films" (in Keilhacker, M. and Stuckrath, F.: *Film jugendpsychologisch betrachtet*, pp. 37-47, München, F. Ehrenwirth, n.d.).
 140. LYNESS, P. I.: "Patterns in the mass communications tastes of the young audience" (*Journal of Educational Psychology*, vol. 42, 1951, pp. 449-467).
 141. MACKWORTH, N. H. and MACKWORTH, J. F.: "Visual search for successive decisions" (*British Journal of Psychology*, vol. 49, 1958, pp. 210-221).
 142. MCCLUSKY, F. D.: *Audio-visual teaching techniques* (Dubuque, Iowa, C. Brown, 1949, 135 pp.).
 143. MACCOBY, E. E. and WILSON, W. C.: "Identification and observational learning from films" (*Journal of Abnormal and Social Psychology*, vol. 55, 1957, pp. 76-87).
 144. MACCOY, E. P.: *In application of research to training film production* (Port Washington, N. Y., Office of Naval Research, Special Devices Center, 1955, 29 pp., Technical report No. SDC 269-7-44).
 145. MARZI, A. and CANESTRARI, R.: "Recherches sur les problèmes du cinéma" (*Revue internationale de filmologie*, vol. 3, 1952, pp. 179-192).
 146. MAY, M. A.: "The psychology of learning from demonstration films" (*Educational Psychology*, vol. 37, 1949, pp. 1-12).
 147. — and LUMSDAINE, A. A.: *Learning from films* (New Haven, Conn., Yale University Press, 1958, 357 pp.).
 148. MEIERHENRY, W. C.: *Enriching the curriculum through motion pictures* (Lincoln, University of Nebraska, 1952, 255 pp.).
 149. MELLINGER, B. E.: *Children's interest in pictures* (New York, Columbia University, Teachers College, Bureau of Publications, 1932, 52 pp.).
 150. *Méthode Decroly* (Film réalisé par l'École Decroly à Bruxelles, Bruxelles, n.d., Non-commercial film).
 151. METZGER, W.: "Kind und Film" (*Psychologie und Praxis*, 1952, No. 11, pp. 18-52).
 152. MIALARET, G.: "Un langage nouveau dans un cadre particulier" (*L'école maternelle française*, 28^e année, No. 7, 1951, pp. 5-7).
 153. —: *Une étude de comportement: la boîte de Decroly* (Film distribué par l'IPN. Paris, Institut pédagogique national, 1954, 16 mm.).

154. —: "Le rendement d'une leçon à l'école primaire" (*Cahiers de pédagogie de l'Université de Liège*, vol. 15, No. 1, 1956, pp. 12-25).
155. —: "Perception and education" (*The Education Quarterly*, Dec. 1956, pp. 337-343).
156. —: *Recherches sur la psychopédagogie des mathématiques* (Unpublished doctoral thesis, Paris, 1957, 558 pp.).
157. —: "Les aspects psychologiques: l'enfant et les aides audiovisuelles" (*Cahier de pédagogie moderne sur les techniques audio-visuelles au service de l'enseignement*, pp. 42-50, Paris, Bourrelier, 1961).
158. — and MALANDAIN, C.: *Recherches sur la compréhension du film fixe. Rapport de recherches* (Saint-Cloud, CREDIF, 1960, 49 pp.).
159. — and —: "Étude de la reconstitution d'un récit chez l'enfant à partir d'un film fixe" (*Enfance*, vol. 12, 1962, pp. 169-190).
160. — and —: "La perception du film fixe chez l'enfant" (*Études de linguistique appliquée*, vol. 1, 1962, pp. 95-103).
161. — and MELIES, M. G.: "Expériences sur la compréhension du langage cinématographique par l'enfant" (*Revue internationale de filmologie*, vol. 5, No. 18-19, 1954, pp. 39-54).
162. MICHAEL, D. N.: *Some factors influencing the effects of audience participation on learning from a factual film* (Washington, D. C., Bolling Air Force Base, Human Resources Research Laboratories, 1951, 46 pp., Memo report No. 13 A).
163. MICHOTTE, A.: *Causalité, permanence et réalité phénoménale (Études de psychologie expérimentale)*, Louvain, B. Nauwelaerts, 1962, 609 pp.).
164. MIRA Y LÓPEZ, E.: "Influence du 'temps psychique' dans la vitesse de perception audio-visuelle" (*Revista de psicologia i pedagogia de la Generalitat de Catalunya*, February 1934).
165. NORBERG, Kenneth: "Perception research and audio-visual education" (*Audio-visual Communication Review*, vol. 1, 1953, pp. 18-29).
166. NOZET, H.: "L'influence du cinéma sur la jeunesse. Études expérimentales" (*Bianco e nero, Roma*, vol. 12, 1951, pp. 79-83).
167. —: *Recherches récentes concernant la production et l'utilisation du film didactique* (Saint-Cloud, Centre audio-visuel, 1955, 11 pp. mimeographed).
168. OLERON, G.: "Influence de la répétition sur la structuration temporelle des mouvements d'accompagnement de la musique" (*Année psychologique*, vol. 1, 1956, pp. 13-26).
169. OSTERRIETH, P. A.: "Le test de copie d'une figure complexe (contribution à l'étude de la perception et de la mémoire)" (*Archives de psychologie*, Neuchâtel, 1944, No. 119-120, 149 pp.).
170. PATEL, A. S.: "Attitudes of adolescent pupils towards cinema

222 *Bibliography*

- films" (*Journal of Education and Psychology, Baroda, Bombay*, 1952, pp. 225-230).
171. PHILIPPON, O.: "L'influence du cinéma sur l'enfance et l'adolescence: l'enquête nationale française" (*Nouvelle revue pédagogique*, 1952, No. 7, pp. 526-530).
172. PIAGET, J.: *La représentation du monde chez l'enfant* (Paris, Presses Universitaires de France, 1947, 425 pp.).
173. — and INHELDER, B.: *La représentation de l'espace chez l'enfant* (Paris, Presses Universitaires de France, 1948, 584 pp.).
174. —: *Les mécanismes perceptifs. (Modèles probabilistes, analyse génétique. Relations avec l'intelligence)* (Paris, Presses universitaires de France, 1961, 457 pp.).
175. PIÉRON, H.: "La connaissance sensorielle et les problèmes de la vision" (in Piéron, H.: *Physiologie des sensations*, vol. 1. Paris, Herman, 1936 et 1951, 92 pp.).
176. —: *Aux sources de la connaissance: Sensation, guide de vie* (Paris, Gallimard, 1945, 628 pp.).
177. —: "Le maniement de la perception" (*Traité de psychologie appliquée*, t. V. Paris, Presses Universitaires de France, 1956, pp. 959-1092).
178. POLLACK, I.: "The information of elementary auditory displays" (*Journal of the Acoustical Society of America*, vol. 24, 1953, pp. 745-749).
179. —: "The information of elementary displays" (*Journal of the Acoustical Society of America*, vol. 25, 1953, pp. 765-769).
180. PRAVERSA, C.: "Psychologie du cinéma" (*Stampa, cinema, radio per ragazzi, Roma*, 1952, pp. 69-75).
181. PRIEBE, R. E. and BURTON, W. H.: "The slow motion picture as a coaching device" (*School Review, Chicago*, vol. 47, 1939, pp. 192-198).
182. PROGER, W.: "Methoden der Jugendfilm-Forschung. Ein Überblick" (*Jugend, Film, Fernsehen*, vol. 3, No. 1, 1959, pp. 1-13).
183. *Psychological study of Film production for child audience (A)* (London, Petroleum Films Bureau, 1952, 36 pp.).
184. "Psychologische bijdragen tot de filmproblematiek" (*Nederlands Tijdschrift voor de Psychologie en haar grensgebieden*, vol. 8, No. 2, 1953, pp. 83-200).
185. REBEILLARD, M.: "Le cinéma et l'enfant" (*L'école des parents*, 1956-1957, No. 4, pp. 30-38).
186. REED, S.: *Film appreciation as a class-room subject* (London, British Film Institute, n.d., 11 pp., Multigraph).
187. REY, A.: "La perception d'un ensemble de déplacements. Données sur l'évolution de la perception cinématique" (*Revue internationale de filmologie*, vol. 5, 1954, pp. 75-92).
188. RONDI, G. L.: "Il cinema e i ragazzi" (*Ragazzi d'oggi, Roma*, vol. 2, No. 3, 1951, pp. 13-18).
189. SAETTLER, P.: "Historical overview of audio-visual com-

- munication" (*Audio-visual Communication Review*, vol. 2, 1954, pp. 109-117).
190. ŠAKAEV, JINKIN and PETRUŠKIN: *A propos de certaines recherches conduites en URSS sur l'utilisation des moyens techniques dans l'enseignement* (Séminaire international sur la psychopédagogie scientifique des aides audio-visuelles dans l'enseignement du premier degré; Caen, 1962, mimeographed. Working document).
191. SALVI, G.: "Ragazzi al cinema" (*Cinema, Roma*, 1953, No. 108, pp. 221-223).
192. SHIPTON, J. and GREY, W. W.: "Les relations entre les activités alpha, les modes de pensée et les affinités sociales" (*Neurophysiology*, suppl. No. 7, pp. 185-202).
193. SICKERT, A.: *Kind und Film. Der Einfluss des Filmes auf das Seelenleben des Kindes. Eine experimentelle Studie unter Verwendung des Pigem- und des Tuanimatestes* (Bern, H. Huber, 1956, 143 pp.).
194. SKINNER, B. F.: *Verbal behavior* (New York, Appleton Century Crofts, 1957, 478 pp.).
195. SLATTERY, M. J.: *An appraisal of the effectiveness of selected instructional sound motion pictures and silent filmstrips in elementary school instruction* (Washington, The Catholic University of America Press, 1953, 67 pp.).
196. SMITH, H. A.: "Intelligence as a factor in the learning which results from the use of educational sound motion pictures" (*Journal of Educational Research*, vol. 46, 1952, pp. 246-261).
197. ŠNEJDER, M.: *Hudožestvennoe kino v vospitatel'noj rabotr školy* (Moskva, Akademija Pedagogiceskih Nauk RSFSR, 1950, 32 pp.).
198. SPAULDING, S.: "Research on pictorial illustration" (*Audio-visual Communication Review*, vol. 3, 1955, pp. 34-35).
199. —: "Communication potential of pictorial illustration" (*Audio-visual Communication Review*, vol. 4, 1956, pp. 31-46).
200. STENIUS, A. C.: "Auditory and visual education" (*Review of Educational Research*, vol. 15, 1945, pp. 243-255).
201. STÜCKRATH, F.: "Das Filmspiel. Erster Bericht über eine neue Methode zur Untersuchung des Filmlebens in Kindheit und Jugend" (*Film, Bild, Ton*, vol. 6, No. 9, 1956, pp. 22-25, 44-47).
202. SUMMERFIELD, A. and LEGGE, D.: "Perception and information theory" (*Bulletin of the British Psychological Society*, vol. 42, 1960, pp. 23-28).
203. TARRONI, E.: "Il film per l'infanzia e il problema del livello di comprensione" (*Rivista del cinematografo, Roma*, 1952, No. 4).
204. —: "L'apporto dell'esperienza filmica alla vita psichica del fanciullo" (*Ragazzi d'oggi, Roma*, 1953, No. 1, pp. 17-20).

224 *Bibliography*

205. — and PADERNI, S.: "Film per ragazzi e pericoli del semplicismo" (*Cinema, Roma*, vol. 5, No. 57, 1951, pp. 99–101, New series).
206. THORPE, L. P. and SCHMULLER, A. M.: *Les théories contemporaines de l'apprentissage et leur application à la pédagogie et à la psychologie* (Paris, Presses Universitaires de France, 1956, 451 pp.).
207. TOMATIS, A.: *L'oreille et le langage* (Paris, Éditions du Seuil, 1963, 187 pp.).
208. VANDROMME, P.: *Le cinéma et l'enfance* (Paris, Éditions du Cerf, 1955, 120 pp.).
209. VERNON, M. D.: "The instruction of children by pictorial illustration" (*British Journal of Educational Psychology*, vol. 23, 1953, pp. 171–178).
210. WALL, W. D. and SIMSON, W. A.: "The effects of cinema attendance on the behaviour of adolescents as seen by their contemporaries" (*British Journal of Educational Psychology*, vol. 20, 1949, pp. 53–61).
211. — and SMITH, E. M.: "Les adolescents et le cinéma" (*Revue internationale de filmologie*, vol. 2, 1951, pp. 153–158).
212. WALLON, H.: *Principes de psychologie appliquée* (Paris, A. Colin, 1930, 224 pp.).
213. —: *L'évolution psychologique de l'enfant* (Paris, A. Colin, 1941, 225 pp.).
214. —: *De l'acte à la pensée* (Paris, Flammarion, 1942, 250 pp.).
215. —: "De quelques problèmes psychophysiologiques que pose le cinéma" (*Revue internationale de filmologie*, 1947, No. 1, pp. 15–18).
216. —: "L'acte perceptif et le cinéma" (*Revue internationale de filmologie*, vol. 4, 1953, pp. 97–110).
217. WASEM, E.: "L'utilisation du 'Wigle test' dans le choix des films pour la jeunesse" (*Jugend und Film, München*, Dec. 1955, pp. 9–12).
218. —: *Jugend und Filmerleben: Beiträge zur Psychologie und Pädagogik der Wirkung des Filmes auf Kinder und Jugendliche* (München, E. Reinhardt, 1957, 140 pp.).
219. WIESE, M. J. and COLE, S. G.: "A study of children's attitudes and the influence of a commercial motion picture" (*Journal of Psychology*, vol. 21, 1946, pp. 151–171).
220. WILNER, D.: *Attitude as a determinant of perception in the mass media of communication reaction to the motion picture "Home of the Brave"* (Doctoral thesis, Los Angeles, University of California, 1950).
221. WISSENSCHAFTLICHES INSTITUT FÜR JUGENDFILMFRAGEN: *Film—jugendpsychologisch betrachtet*, München, Ehrenwirth Verlag, n.d., 76 pp.).
222. WYETH, E. R.: "Children and the cinema. A summary of a survey" (*Visual Aids Review*, vol. 1, 1950, pp. 20–22).
223. Yale University Motion Picture Research Project: "Do moti-

- vation and participation questions increase learning?" (*Educational Screen*, vol. 26, 1947, pp. 256).
224. ZANKOV, L. V.: *Enseignement oral et enseignement visuel* (Séminaire international sur la psychopédagogie scientifique des aides audio-visuelles dans l'enseignement du premier degré; Caen, 1962. Working document).
225. ZAZZO, B.: "Analyse des difficultés d'une séquence cinématographique par la conduite du récit chez l'enfant" (*Revue internationale de filmologie*, vol. 3, 1952, pp. 25-36).
226. —: *Effets de la grosseur et de la mobilité des plans sur les réactions des spectateurs enfants* (Communication faite au II^e Congrès international de filmologie, Paris, 1955).
227. — and ZAZZO, R.: "Une expérience sur la compréhension du film" (*Revue internationale de filmologie*, vol. 2, 1951, pp. 159-170).
228. — and —: "La jeunesse et le cinéma; étude expérimentale du Centre international de l'enfance effectuée au Laboratoire de psychobiologie de l'enfant (École pratique des hautes études)" (*Courrier du Centre international de l'enfance*, vol. 8, 1958, pp. 185-197).
229. ZAZZO, R.: "Niveau mental et compréhension du cinéma" (*Revue internationale de filmologie*, vol. 2, 1951, pp. 29-36).
230. —: "Réactions psychologiques de l'enfant devant l'écran" (in Thomet, M. and Hebraud, Y.: *Le film au service de la première éducation*, pp. 26-34, Paris, Bourrelier, 1954).
231. —: "L'influence du cinéma sur le développement de la pensée de l'enfant" (*L'école des parents*, Jan. 1956, pp. 1-14).
232. — and ZAZZO, B.: "Le concours international du film récréatif pour enfants" (*Courrier du Centre international de l'enfance*, vol. 4. No. 5, 1954, pp. 235-258).
233. — et al.: *Manuel de psychologie de l'enfant* (Neuchâtel, Delachaux et Niestlé, 1960, 435 pp.).
234. ZUCKERMAN, J. W.: *Commentary variations: level of verbalizations, personal reference, and phase relations in instructional films on perceptual-motor tasks* (Port Washington, N. Y., Office of Naval Research, Special Devices Center, 1949, 63 pp., Technical report No. SDC 269-7-4).